

# Overview of the Cisco 2524 and Cisco 2525 Routers

---

The Cisco 2524 and Cisco 2525 routers provide LAN and WAN access in a low-cost modular router platform that can grow with your internetworking needs. The Cisco 2524 offers an Ethernet (attachment unit interface [AUI] or 10BaseT) LAN connection, and the Cisco 2525 offers a Token Ring (shielded twisted-pair [STP] or unshielded twisted-pair [UTP]) LAN connection. Both routers can accommodate up to three WAN modules—two synchronous serial and one Integrated Services Digital Network (ISDN).

The choice of synchronous serial WAN modules is as follows:

- 2-wire switched 56-kbps data service unit/channel service unit (DSU/CSU)
- 4-wire 56/64-kbps DSU/CSU
- Fractional T1/T1 DSU/CSU
- Five-in-one synchronous serial

---

**Note** The five-in-one synchronous serial WAN module gets its name from the five types of signaling it supports: EIA/TIA-232, EIA/TIA-449, V.35, X.21, and EIA-530. You can order from Cisco Systems a DB-60 shielded serial transition cable. The router end of the shielded serial transition cable has a DB-60 connector; the other end of the cable has the appropriate connector for the standard interface you specify.

---

The choice of ISDN WAN modules is as follows:

- ISDN Basic Rate Interface (BRI)
- ISDN with integrated network termination 1 (NT1) device

The ISDN WAN modules are designed so that you cannot insert them into the synchronous serial WAN slots. A blank slot cover is installed over unused slots.

## Features

The Cisco 2524 and Cisco 2525 routers include the following features:

- Three slots for WAN modules
- One Ethernet (AUI or 10BaseT) interface on the Cisco 2524 router
- One Token Ring (STP or UTP) interface on the Cisco 2525 router
- Dynamic random-access memory (DRAM) for main system memory and shared memory
- Nonvolatile random-access memory (NVRAM) for storing configuration information
- Flash memory for running Cisco IOS software
- EIA/TIA-232 console port for connecting a console terminal
- EIA/TIA-232 auxiliary port for connecting a terminal or modem

---

**Note** EIA/TIA-232 and EIA/TIA-449 were known as recommended standards RS-232 and RS-449 before their acceptance as standards by the Electronic Industries Association (EIA) and Telecommunications Industry Association (TIA).

---

Figure 1-1 shows the front panel, which is the same for both routers.

**Figure 1-1 Cisco 2524 and Cisco 2525 Front Panel**



Figure 1-2 shows the rear panel of the Cisco 2524 router, and Figure 1-3 shows the rear panel of the Cisco 2525 router.

**Figure 1-2 Cisco 2524 Rear Panel**

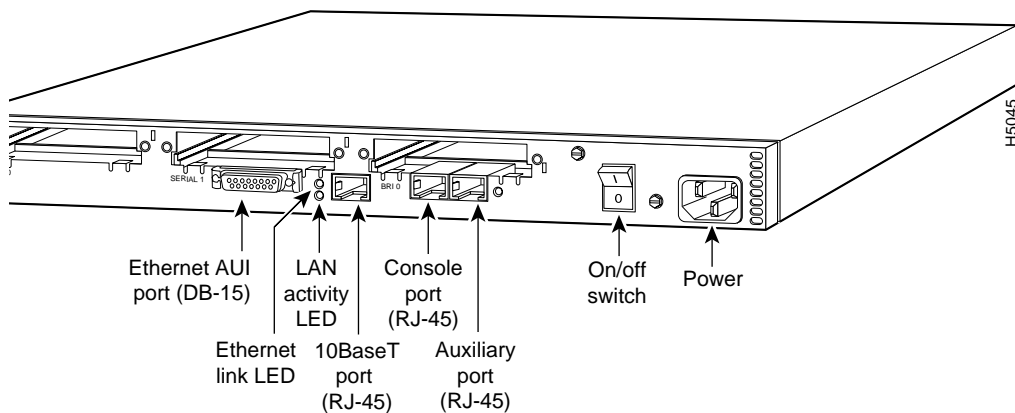

**Figure 1-3 Cisco 2525 Rear Panel**

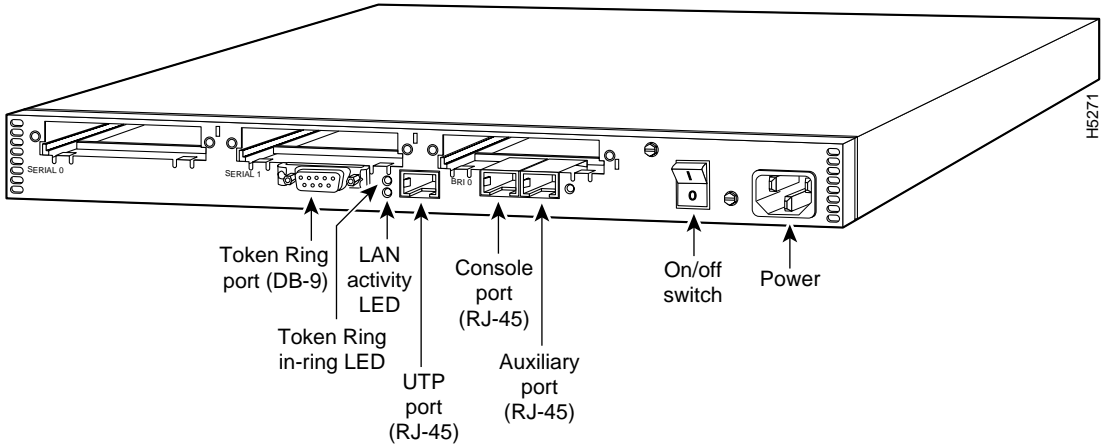
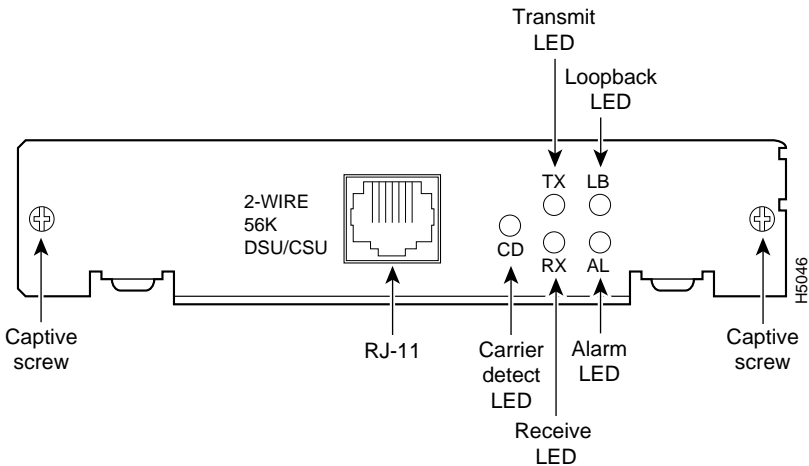
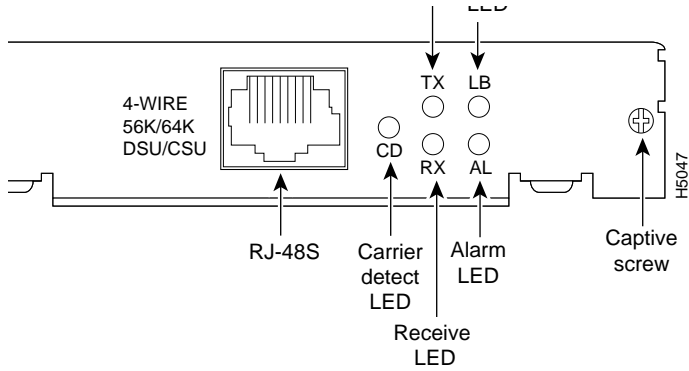

Figure 1-4 through Figure 1-9 show the WAN modules. Figure 1-10 shows the blank slot cover.

**Figure 1-4 2-Wire Switched 56-kbps DSU/CSU WAN Module**



**Figure 1-5 4-Wire 56K/64K DSU/CSU WAN Module**



**Figure 1-6 Fractional T1/T1 DSU/CSU WAN Module**

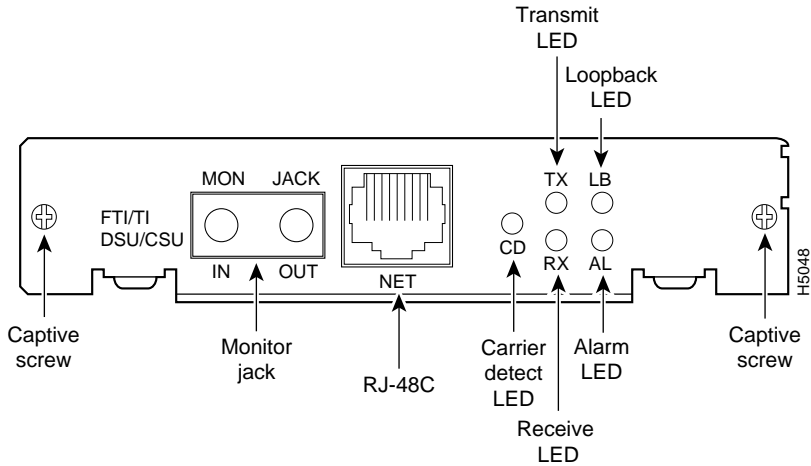

**Figure 1-7 Five-in-One Synchronous Serial WAN Module**

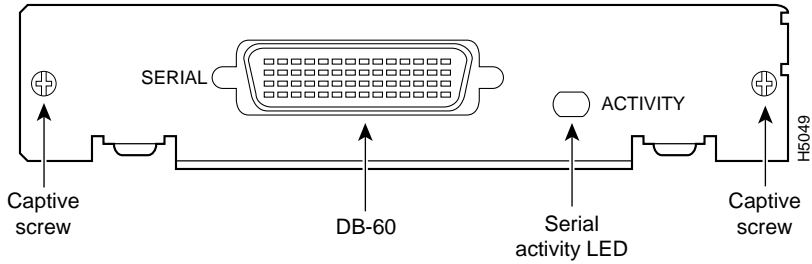

**Figure 1-8 ISDN BRI WAN Module**

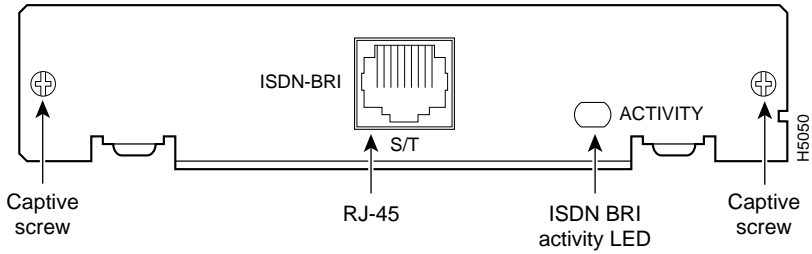

**Figure 1-9 ISDN BRI with Integrated NT1 WAN Module**

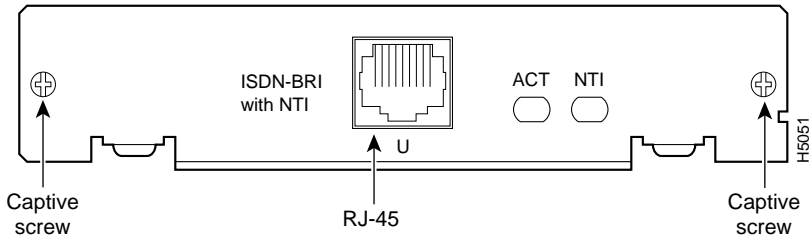

**Figure 1-10 Blank Slot Cover**

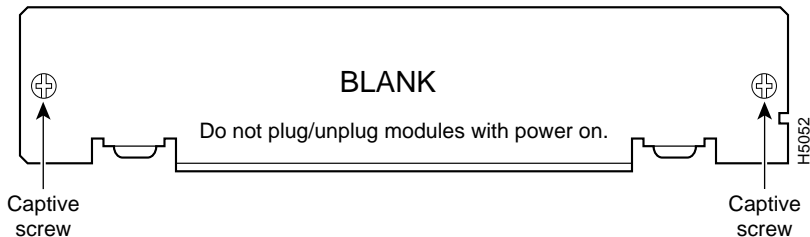

## Specifications

The specifications of the Cisco 2524 and Cisco 2525 routers are listed in Table 1-1.

**Table 1-1 System Specifications**

Description	Specification
Dimensions (H x W x D)	1.75 x 17.5 x 10.56" one rack unit (4.44 x 44.45 x 26.82 cm)
Weight	10 lb (4.5 kg)
Input voltage, AC power supply	100–240 VAC <sup>1</sup>
Current	1.2–0.6A
Frequency	50–60 Hz
Power dissipation	40W (maximum), 135.5 Btus <sup>2</sup> /hr
Input voltage, DC power supply	40W, 40–72 VDC <sup>3</sup>
Current	1.5–1.0A
Power dissipation	40W (maximum), 135.5 Btus/hr
Processor	20-MHz Motorola 68EC030

## Specifications

---

Description	Specification
WAN interface options	<ul style="list-style-type: none"><li>• 2-wire switched 56-kbps DSU/CSU (RJ-11)</li><li>• 4-wire 56/64-DSU/CSU (RJ-48S)</li><li>• Fractional T1/T1 DSU/CSU (RJ-48C)</li><li>• Five-in-one synchronous serial (DB-60)</li><li>• ISDN BRI (RJ-45)</li><li>• ISDN BRI with integrated NT1 (RJ-45)</li></ul>
LAN interface options	Cisco 2524: Ethernet AUI (DB-15) or 10BaseT (RJ-45) Cisco 2525: Token Ring STP (DB-9) or UTP (RJ-45)
Synchronous serial interfaces (five-in-one synchronous serial WAN module)	<ul style="list-style-type: none"><li>• EIA/TIA-232, EIA/TIA-449, V.35, X.21 (NRZ/NRZI<sup>4</sup> and DTE/DCE<sup>5</sup> mode)</li><li>• EIA-530 (NRZ/NRZI and DTE mode)</li><li>• The five-in-one synchronous serial interface uses the DB-60 connector at the chassis</li></ul>
Console and auxiliary ports	Asynchronous serial (RJ-45)
Operating environment	32–104°F (0–40°C)
Nonoperating temperature	–40–185°F (–40–85°C)
Operating humidity	5–95%, noncondensing
Noise level	34 dB <sup>6</sup> @ 3' (0.914 m)
Regulatory compliance	<ul style="list-style-type: none"><li>• 2-wire switched 56-kbps DSU/CSU module: FCC Class A, Part 15</li><li>• 4-wire 56/64-kbps DSU/CSU module: FCC Class A, Part 15 and FCC Part 68</li><li>• Fractional T1/T1 DSU/CSU module: FCC Class A, Part 15 and FCC Part 68</li></ul>

1. VAC = volts alternating current.

2. BTU = British thermal unit.

3. VDC = volts direct current.

4. NRZ = nonreturn to zero; NRZI = nonreturn to zero inverted.

5. DTE = data terminal equipment; DCE = data communications equipment.

6. dB = decibels.

## FCC Part 68

The following text is required for FCC Part 68 regulatory compliance:

The equipment complies with Part 68 of the FCC rules. On the bottom of the equipment is a label that shows the FCC registration number.

If the equipment causes harm to the telephone network, the telephone company may temporarily discontinue service. If possible, advance notification is given; otherwise, notification is given as soon as possible. The telephone company will advise the customer of the right to file a complaint with the FCC.

The telephone company may make changes in its facility, equipment, operations, or procedures that could affect the proper operation of the equipment; advance notification and the opportunity to maintain uninterrupted service will be given.

If you experience difficulty with the Cisco 2524 or Cisco 2525 router, please contact Cisco Systems at 800 553-NETS (6387) or 408 526-4000 for repair and warranty information. If your equipment is causing harm to the telephone network, the telephone company may request that you disconnect the equipment until the problem is resolved.

The module contains no user-serviceable parts.

An FCC-compliant telephone cord and a modular plug is provided with the equipment. The equipment is designed to be connected to the telephone network or premises wiring using an FCC-compatible modular jack that is Part 68 compliant.

Table 1-2 lists information that may be required when applying to the local telephone company for leased-line facilities.

**Table 1-2 Information About Leased-Line Facilities**

<b>Module Type</b>	<b>Service Type</b>	<b>Digital Facility Interface Code</b>	<b>Service Order Code</b>	<b>Network Jack</b>
4-Wire 56/64-kbps DSU/CSU WAN Module	2.4-kbps digital interface	04DU5-24	6.0F	RJ-48S
	4.8-kbps digital interface	04DU5-48	6.0F	RJ-48S
	9.6-kbps digital interface	04DU5-96	6.0F	RJ-48S
	19.2-kbps digital interface	04DU5-19	6.0F	RJ-48S
	38.4-kbps digital interface	04DU5-38	6.0F	RJ-48S
	56-kbps digital interface	04DU5-56	6.0F	RJ-48S
	64-kbps digital interface	04DU5-64	6.0F	RJ-48S
Fractional T1/T1 DSU/CSU WAN Module	1.544-Mbps digital interface	04DU9-ISN	6.0N	RJ-48C