



PA-8E 10BaseT Ethernet Port Adapter Installation and Configuration

Product Number: PA-8E=

Platforms Supported: Catalyst 5000 Family Switches with RSM/VIP2, Cisco 7100 Series Routers, Cisco 7200 Series Routers, Cisco uBR7200 Series Routers, Cisco 7200 VXR Routers, Cisco 7201 Router, Cisco 7301 Router, Cisco 7304 PCI Port Adapter Carrier Card in the Cisco 7304 Router, Cisco 7401ASR Router, and VIP in the Cisco 7000 Series and Cisco 7500 Series Routers

Americas Headquarters
Cisco Systems, Inc.
170 West Tasman Drive
San Jose, CA 95134-1706
USA
<http://www.cisco.com>
Tel: 408 526-4000
800 553-NETS (6387)
Fax: 408 527-0883

Text Part Number: OL-3494-04

THE SPECIFICATIONS AND INFORMATION REGARDING THE PRODUCTS IN THIS MANUAL ARE SUBJECT TO CHANGE WITHOUT NOTICE. ALL STATEMENTS, INFORMATION, AND RECOMMENDATIONS IN THIS MANUAL ARE BELIEVED TO BE ACCURATE BUT ARE PRESENTED WITHOUT WARRANTY OF ANY KIND, EXPRESS OR IMPLIED. USERS MUST TAKE FULL RESPONSIBILITY FOR THEIR APPLICATION OF ANY PRODUCTS.

THE SOFTWARE LICENSE AND LIMITED WARRANTY FOR THE ACCOMPANYING PRODUCT ARE SET FORTH IN THE INFORMATION PACKET THAT SHIPPED WITH THE PRODUCT AND ARE INCORPORATED HEREIN BY THIS REFERENCE. IF YOU ARE UNABLE TO LOCATE THE SOFTWARE LICENSE OR LIMITED WARRANTY, CONTACT YOUR CISCO REPRESENTATIVE FOR A COPY.

The following information is for FCC compliance of Class A devices: This equipment has been tested and found to comply with the limits for a Class A digital device, pursuant to part 15 of the FCC rules. These limits are designed to provide reasonable protection against harmful interference when the equipment is operated in a commercial environment. This equipment generates, uses, and can radiate radio-frequency energy and, if not installed and used in accordance with the instruction manual, may cause harmful interference to radio communications. Operation of this equipment in a residential area is likely to cause harmful interference, in which case users will be required to correct the interference at their own expense.

The following information is for FCC compliance of Class B devices: The equipment described in this manual generates and may radiate radio-frequency energy. If it is not installed in accordance with Cisco's installation instructions, it may cause interference with radio and television reception. This equipment has been tested and found to comply with the limits for a Class B digital device in accordance with the specifications in part 15 of the FCC rules. These specifications are designed to provide reasonable protection against such interference in a residential installation. However, there is no guarantee that interference will not occur in a particular installation.

Modifying the equipment without Cisco's written authorization may result in the equipment no longer complying with FCC requirements for Class A or Class B digital devices. In that event, your right to use the equipment may be limited by FCC regulations, and you may be required to correct any interference to radio or television communications at your own expense.

You can determine whether your equipment is causing interference by turning it off. If the interference stops, it was probably caused by the Cisco equipment or one of its peripheral devices. If the equipment causes interference to radio or television reception, try to correct the interference by using one or more of the following measures:

- Turn the television or radio antenna until the interference stops.
- Move the equipment to one side or the other of the television or radio.
- Move the equipment farther away from the television or radio.
- Plug the equipment into an outlet that is on a different circuit from the television or radio. (That is, make certain the equipment and the television or radio are on circuits controlled by different circuit breakers or fuses.)

Modifications to this product not authorized by Cisco Systems, Inc. could void the FCC approval and negate your authority to operate the product.

The Cisco implementation of TCP header compression is an adaptation of a program developed by the University of California, Berkeley (UCB) as part of UCB's public domain version of the UNIX operating system. All rights reserved. Copyright © 1981, Regents of the University of California.

NOTWITHSTANDING ANY OTHER WARRANTY HEREIN, ALL DOCUMENT FILES AND SOFTWARE OF THESE SUPPLIERS ARE PROVIDED "AS IS" WITH ALL FAULTS. CISCO AND THE ABOVE-NAMED SUPPLIERS DISCLAIM ALL WARRANTIES, EXPRESSED OR IMPLIED, INCLUDING, WITHOUT LIMITATION, THOSE OF MERCHANTABILITY, FITNESS FOR A PARTICULAR PURPOSE AND NONINFRINGEMENT OR ARISING FROM A COURSE OF DEALING, USAGE, OR TRADE PRACTICE.

IN NO EVENT SHALL CISCO OR ITS SUPPLIERS BE LIABLE FOR ANY INDIRECT, SPECIAL, CONSEQUENTIAL, OR INCIDENTAL DAMAGES, INCLUDING, WITHOUT LIMITATION, LOST PROFITS OR LOSS OR DAMAGE TO DATA ARISING OUT OF THE USE OR INABILITY TO USE THIS MANUAL, EVEN IF CISCO OR ITS SUPPLIERS HAVE BEEN ADVISED OF THE POSSIBILITY OF SUCH DAMAGES.

CCVP, the Cisco Logo, and the Cisco Square Bridge logo are trademarks of Cisco Systems, Inc.; Changing the Way We Work, Live, Play, and Learn is a service mark of Cisco Systems, Inc.; and Access Registrar, Aironet, BPX, Catalyst, CCDA, CCDP, CCIE, CCIP, CCNA, CCNP, CCSP, Cisco, the Cisco Certified Internetwork Expert logo, Cisco IOS, Cisco Press, Cisco Systems, Cisco Systems Capital, the Cisco Systems logo, Cisco Unity, Enterprise/Solver, EtherChannel, EtherFast, EtherSwitch, Fast Step, Follow Me Browsing, FormShare, GigaDrive, HomeLink, Internet Quotient, IOS, iPhone, IP/TV, iQ Expertise, the iQ logo, iQ Net Readiness Scorecard, iQuick Study, LightStream, Linksys, MeetingPlace, MGX, Networking Academy, Network Registrar, Packet, PIX, ProConnect, RateMUX, ScriptShare, SlideCast, SMARTnet, StackWise, The Fastest Way to Increase Your Internet Quotient, and TransPath are registered trademarks of Cisco Systems, Inc. and/or its affiliates in the United States and certain other countries.

All other trademarks mentioned in this document or Website are the property of their respective owners. The use of the word partner does not imply a partnership relationship between Cisco and any other company. (0704R)

PA-8E 10BaseT Ethernet Port Adapter Installation and Configuration

Copyright © 1996–2007, Cisco Systems, Inc.

All rights reserved.



CONTENTS

Preface	vii
Document Revision History	vii
Objectives	vii
Organization	viii
Related Documentation	viii
Obtaining Documentation, Obtaining Support, and Security Guidelines	xi

CHAPTER 1

Overview	1-1
Port Adapter Overview	1-1
Ethernet 10BaseT Overview	1-2
IEEE 802.3 10BaseT Specifications	1-3
PA-8E LEDs	1-4
Cables, Connectors, and Pinouts	1-5
Port Adapter Slot Locations on the Supported Platforms	1-6
Catalyst RSM/VIP2 Slot Numbering	1-7
Cisco 7100 Series Routers Slot Numbering	1-8
Cisco 7200 Series Routers and Cisco 7200 VXR Routers Slot Numbering	1-8
Cisco uBR7200 Series Router Slot Numbering	1-9
Cisco 7201 Router Slot Numbering	1-10
Cisco 7301 Router Slot Numbering	1-11
Cisco 7304 PCI Port Adapter Carrier Card Slot Numbering	1-11
Cisco 7401ASR Router Slot Numbering	1-12
Cisco 7000 Series Routers and Cisco 7500 Series Routers VIP Slot Numbering	1-13
Identifying Interface Addresses	1-14
Catalyst RSM/VIP2 Interface Addresses	1-15
Cisco 7100 Series Routers Interface Addresses	1-16
Cisco 7200 Series Routers and Cisco 7200 VXR Routers Interface Addresses	1-16
Cisco uBR7200 Series Routers Interface Addresses	1-16
Cisco 7201 Router Interface Addresses	1-16
Cisco 7301 Router Interface Addresses	1-17
Cisco 7304 PCI Port Adapter Carrier Card Interface Addresses	1-17
Cisco 7401ASR Router Interface Addresses	1-17

Cisco 7000 Series Routers and Cisco 7500 Series Routers VIP Interface Addresses 1-17

CHAPTER 2

Preparing for Installation 2-1

- Required Parts and Tools 2-1
- Software and Hardware Requirements 2-2
- Checking Hardware and Software Compatibility 2-3
- Safety Guidelines 2-4
 - Safety Warnings 2-4
 - Electrical Equipment Guidelines 2-9
 - Telephone Wiring Guidelines 2-9
 - Preventing Electrostatic Discharge Damage 2-9
- FCC Class B Compliance 2-10

CHAPTER 3

Removing and Installing Port Adapters 3-1

- Handling Port Adapters 3-1
- Online Insertion and Removal 3-2
- Warnings and Cautions 3-3
- Port Adapter Removal and Installation 3-4
 - Catalyst RSM/VIP2—Removing and Installing a Port Adapter 3-5
 - Cisco 7100 Series Routers—Removing and Installing a Port Adapter 3-6
 - Cisco 7200 Series Routers and Cisco 7200 VXR Routers—Removing and Installing a Port Adapter 3-7
 - Cisco uBR7200 Series Routers—Removing a Port Adapter 3-8
 - Cisco uBR7200 Series Routers—Installing a Port Adapter 3-9
 - Cisco 7201 Router—Removing and Installing a Port Adapter 3-10
 - Cisco 7301 Router—Removing and Installing a Port Adapter 3-11
 - Cisco 7304 PCI Port Adapter Carrier Card—Removing and Installing a Port Adapter 3-12
 - Cisco 7401ASR Router—Removing and Installing a Port Adapter 3-14
 - VIP—Removing and Installing a Port Adapter 3-15
- Connecting PA-8E Interface Cables 3-16

CHAPTER 4

Configuring the PA-8E 4-1

- Using the EXEC Command Interpreter 4-1
- Configuring the PA-8E Interfaces 4-2
 - Shutting Down an Interface 4-2
 - Performing a Basic Interface Configuration 4-8
- Checking the Configuration 4-10
 - Using show Commands to Verify the New Interface Status 4-10

Using the show version or show hardware Commands	4-12
Using the show diag Command	4-15
Using the show interfaces Command	4-18
Using the ping Command to Verify Network Connectivity	4-24



Preface

This preface describes the objectives and organization of this document and explains how to find additional information on related products and services. This preface contains the following sections:

- [Document Revision History, page vii](#)
- [Objectives, page vii](#)
- [Organization, page viii](#)
- [Related Documentation, page viii](#)
- [Obtaining Documentation, Obtaining Support, and Security Guidelines, page xi](#)

Document Revision History

The Document Revision History table below, beginning with version OL-3494-04, records technical changes to this document.

Document Version	Date	Change Summary
OL-3494-04	April, 2007	Adds Cisco 7201 router information.

Objectives

This document describes how to install and configure the PA-8E 10BaseT Ethernet port adapter (PA-8E), hereafter referred to as the PA-8E, which is used in the following platforms:

- Catalyst 5000 family switches with the Route Switch Module (RSM)/second-generation Versatile Interface Processor (VIP2)
- Cisco 7100 series routers, consisting of the Cisco 7120 series and Cisco 7140 series
- Cisco 7200 series routers and Cisco 7200 VXR routers, consisting of the two-slot Cisco 7202, four-slot Cisco 7204 and Cisco 7204VXR, and the six-slot Cisco 7206 and Cisco 7206VXR
- Cisco uBR7200 series universal broadband routers, consisting of the three-slot Cisco uBR7223 and the six-slot Cisco uBR7246 and Cisco uBR7246VXR
- Cisco 7201 router
- Cisco 7301 router
- Cisco 7304 PCI Port Adapter Carrier Card in the Cisco 7304 router

- Cisco 7401ASR router
- Versatile Interface Processor (VIP) in Cisco 7500 series and Cisco 7000 series routers with the 7000 Series Route Switch Processor (RSP7000) and 7000 Series Chassis Interface (RSP7000CI)

Organization

This document contains the following chapters:

Section	Title	Description
Chapter 1	Overview	Describes the PA-8E and its LED displays, cables, and receptacles.
Chapter 2	Preparing for Installation	Describes safety considerations, tools required, and procedures you should perform before the actual installation.
Chapter 3	Removing and Installing Port Adapters	Describes the procedures for installing and removing the PA-8E in the supported platforms.
Chapter 4	Configuring the PA-8E	Provides instructions for configuring the PA-8E on the supported platforms.

Related Documentation

Your router or switch and the Cisco IOS software running on it contain extensive features and functionality, which are documented in the following resources:

- Cisco IOS software:

For configuration information and support, refer to the modular configuration and modular command reference publications in the Cisco IOS software configuration documentation set that corresponds to the software release installed on your Cisco hardware.



Note You can access Cisco IOS software configuration and hardware installation and maintenance documentation on the World Wide Web at <http://www.cisco.com>, <http://www-china.cisco.com>, or <http://www-europe.cisco.com>.

- Catalyst 5000 family switches with RSM/VIP2:
 - For an online directory to quickly access documents for Cisco Catalyst 5000 series switches, refer to the *Cisco Catalyst 5000 Series Switches Install and Upgrade Guides* index at the following URL:
http://www.cisco.com/en/US/products/hw/switches/ps679/prod_installation_guides_list.html
 - For hardware installation and maintenance information, refer to the following documents:
 - *Route Switch Module Catalyst VIP2-15 and VIP2-40 Installation and Configuration Note*
 - *Catalyst 5000 Series Route Switch Module Installation and Configuration Note*
 - The installation and configuration guide and quick start for your Cisco Catalyst 5000 series switch
- Cisco 7000 series routers:
 - For an online directory to quickly access documents for Cisco 7000 series routers, refer to the *Cisco 7000 Series Routers Introduction* index at the following URL:
http://www.cisco.com/en/US/products/hw/routers/ps332/tsd_products_support_eol_series_home.html
 - For hardware installation and maintenance information, refer to the following documents:
 - *Cisco 7000 Hardware Installation and Maintenance* for your router.
 - *Second-Generation Versatile Interface Processor (VIP2) Installation and Configuration*
 - *Fourth-Generation Versatile Interface Processor (VIP4) Installation and Configuration*
 - *Versatile Interface Processor (VIP6-80) Installation and Configuration Guide*
- Cisco 7100 series routers:
 - For an online directory to quickly access documents for Cisco 7100 series routers, refer to the *Cisco 7100 Series Documentation* roadmap at the following URL:
http://www.cisco.com/en/US/products/hw/vpndevc/ps333/products_product_index09186a00800fa142.html
 - For hardware installation and configuration information refer to the *Cisco 7100 Series VPN Router Installation and Configuration Guide*.
 - For information on setting up a Virtual Private Network, refer to the *Cisco 7100 Series VPN Configuration Guide*.
- Cisco 7200 series routers:
 - For an online directory to quickly access documents for Cisco 7200 series routers, refer to the *Cisco 7200 Series Routers Documentation Roadmap* at the following URL:
http://www.cisco.com/en/US/products/hw/routers/ps341/products_documentation_roadmap09186a00801c0915.html
 - For hardware installation and configuration information (including the Cisco 7206 or Cisco 7206VXR as a router shelf in a Cisco AS5800 Universal Access Server), refer to the online installation and configuration guide and quick start for your Cisco 7200 series router.
 - For port adapter hardware and memory configuration guidelines, refer to the *Cisco 7200 Series Port Adapter Hardware Configuration Guidelines*.
 - For information on network processing engines or network services engines, refer to the *Network Processing Engine and Network Services Engine Installation and Configuration* document.

- Cisco 7200 VXR routers:
 - For an online directory to quickly access documents for Cisco 7200 VXR routers, refer to the *Cisco 7200 Series Routers Documentation Roadmap* at the following URL:
http://www.cisco.com/en/US/products/hw/routers/ps341/products_documentation_roadmap09186a00801c0915.html
 - For hardware installation and maintenance information, refer to the *Cisco 7200 VXR Installation and Configuration Guide* or the *Cisco 7200 VXR Routers Quick Start Guide*.
- Cisco uBR7200 series routers:
 - For an online directory to quickly access documents for Cisco uBR7200 Universal Broadband routers, refer to the *Cisco uBR7200 Universal Broadband Router Documentation Roadmap* at the following URL:
http://www.cisco.com/en/US/products/hw/cable/ps2217/products_documentation_roadmap09186a00805e0d0c.html
- Cisco 7201 router:
 - For an online directory to quickly access documents for the Cisco 7201 router, refer to the *Cisco 7201 Router Documentation Roadmap* at the following URL:
http://www.cisco.com/en/US/customer/products/hw/routers/ps341/products_documentation_roadmap09186a00807f635a.html
 - For hardware installation and maintenance information, refer to the *Cisco 7201 Installation and Configuration Guide* or the *Cisco 7201 Router Quick Start Guide*.
- Cisco 7301 router:
 - For an online directory to quickly access documents for the Cisco 7301 router, refer to the *Cisco 7301 Internet Router Documentation Roadmap* at the following URL:
http://www.cisco.com/en/US/products/hw/routers/ps352/products_documentation_roadmap09186a00801c0f21.html
 - For hardware installation and maintenance information, refer to the *Cisco 7301 Installation and Configuration Guide* or the *Cisco 7301 Router Quick Start Guide*.
- Cisco 7304 PCI Port Adapter Carrier Card in Cisco 7304 router:
 - For an online directory to quickly access documents for the Cisco 7304 PCI Port Adapter Carrier Card in the Cisco 7301 router, refer to the *Cisco 7304 Router Line Card, Carrier Card, Port Adapter, Modular Services Card, and Shared Port Adapter Documentation Roadmap* at the following URL:
http://www.cisco.com/en/US/products/hw/routers/ps352/products_documentation_roadmap09186a00801c0f5e.html
 - For hardware installation and maintenance information, refer to the *Cisco 7304 PCI Port Adapter Carrier Card Installation and Configuration Guide*.
- Cisco 7401ASR router:
 - For an online directory to quickly access documents for the Cisco 7401ASR router, refer to the *Cisco 7401ASR Router Documentation Roadmap* at the following URL:
http://www.cisco.com/en/US/products/hw/routers/ps354/products_documentation_roadmap09186a00801c0fd5.html
 - For hardware installation and maintenance information, refer to the *Cisco 7401ASR Installation and Configuration Guide* or the *Cisco 7401ASR Router Quick Start Guide*.

- Cisco 7500 series routers:
 - For an online directory to quickly access documents for the Cisco 7500 series routers, refer to the *Cisco 7500 Series Routers Documentation Roadmap* at the following URL:
http://www.cisco.com/en/US/products/hw/routers/ps359/products_documentation_roadmap09186a00801c0f9b.html
 - For hardware installation and maintenance information, refer to the following documents:
 - *Cisco 7500 Series Installation and Configuration Guide* or the quick start for your Cisco 7500 series router.
 - *Second-Generation Versatile Interface Processor (VIP2) Installation and Configuration*
 - *Fourth-Generation Versatile Interface Processor (VIP4) Installation and Configuration*
 - *Versatile Interface Processor (VIP6-80) Installation and Configuration Guide*
- For international agency compliance, safety, and statutory information for WAN interfaces, refer to the following documents. Use the documentation roadmap for your particular router to link to the appropriate documents for your router:
 - *Regulatory Compliance and Safety Information for the Catalyst 5000 Family Switches*
 - *Regulatory Compliance and Safety Information for the Cisco 7000 Series Routers*
 - *Regulatory Compliance and Safety Information for Cisco 7100 Series VPN Routers*
 - *Regulatory Compliance and Safety Information for the Cisco 7200 Series Routers*
 - *Regulatory Compliance and Safety Information for the Cisco uBR7200 Series Universal Broadband Routers*
 - *Regulatory Compliance and Safety Information for the Cisco 7301 Internet Router*
 - *Regulatory Compliance and Safety Information for the Cisco 7304 Internet Router*
 - *Regulatory Compliance and Safety Information for the Cisco 7401ASR Internet Router*
 - *Regulatory Compliance and Safety Information for the Cisco 7500 Series Routers*

Obtaining Documentation, Obtaining Support, and Security Guidelines

For information on obtaining documentation, obtaining support, providing documentation feedback, security guidelines, and also recommended aliases and general Cisco documents, see the monthly What's New in Cisco Product Documentation, which also lists all new and revised technical documentation at:

<http://www.cisco.com/en/US/docs/general/whatsnew/whatsnew.html>



CHAPTER 1

Overview

This chapter provides physical and functional overviews of the PA-8E port adapter. The chapter contains the following sections:

- [Port Adapter Overview, page 1-1](#)
- [Ethernet 10BaseT Overview, page 1-2](#)
- [PA-8E LEDs, page 1-4](#)
- [Cables, Connectors, and Pinouts, page 1-5](#)
- [Port Adapter Slot Locations on the Supported Platforms, page 1-6](#)
- [Identifying Interface Addresses, page 1-14](#)

Port Adapter Overview

The PA-8E, shown in [Figure 1-1](#), provides up to eight IEEE 802.3 Ethernet 10BaseT interfaces. Each Ethernet 10BaseT interface allows a maximum bandwidth of 10 Mbps, for a maximum aggregate bandwidth of 80 Mbps. All eight ports run at line (wire) speed.



Note

Cisco 7500 series routers support full-duplex mode on PA-8E.

Figure 1-1 PA-8E—Faceplate View

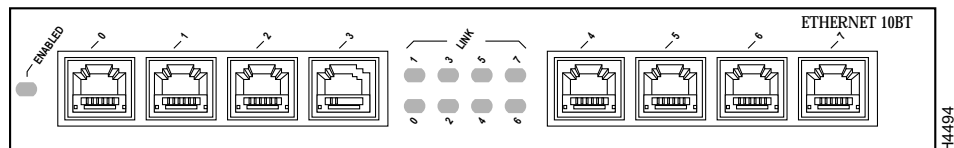

The PA-8E can be installed in the following slots on the hardware platforms described in this document:

- VIP (in the Cisco 7000 series and Cisco 7500 series routers)—Port adapter slot 0 and port adapter slot 1
- Catalyst RSM/VIP2 (in a Catalyst 5000 family switch)—Port adapter slot 0 and port adapter slot 1
- Cisco 7304 PCI Port Adapter Carrier Card (in the Cisco 7304 router)—router module slots 2 through 5
- Cisco 7200 series routers and Cisco 7200 VXR routers—Port adapter slot 1 and slot 2 of the Cisco 7202 router; port adapter slot 1 through slot 4 of the Cisco 7204 router and Cisco 7204VXR router; port adapter slot 1 through slot 6 of the router and Cisco 7206VXR router
- Cisco 7100 series routers—Port adapter slot 3 in the Cisco 7120 series router, and port adapter slot 4 in the Cisco 7140 series router
- Cisco uBR7200 series universal broadband routers—Port adapter slot 1 of the Cisco uBR7223 router; port adapter slot 1 and slot 2 of the Cisco uBR7246 router and Cisco uBR7246 VXR router
- Cisco 7201 router—Port adapter slot 1
- Cisco 7301 router—Port adapter slot 1
- Cisco 7401ASR router—Port adapter slot 1

Port adapters have a handle attached, but this handle is not always shown in the figures to allow a full view of detail on the port adapter faceplate.

Ethernet 10BaseT Overview

The term *Ethernet* is commonly used for all carrier sense multiple access/collision detect (CSMA/CD) LANs that generally conform to Ethernet specifications, including IEEE 802.3. Ethernet Version 2 and IEEE 802.3 were based on and developed shortly after Ethernet Version 1. The slight differences between Ethernet and IEEE 802.3 are implemented in hardware, and both are supported automatically by the Ethernet 10BaseT port adapter without any hardware configuration changes. Ethernet and IEEE 802.3 are the most widely used LAN protocols. They are well suited to applications in which a local communication medium must carry sporadic, occasionally heavy traffic at high peak data rates.

Stations on a CSMA/CD LAN can access the network at any time. Before sending data, the station listens to the network to see if it is already in use. If the network is in use, the station waits until the network is not in use, and then transmits. A collision occurs when two stations listen for network traffic, and do not hear any, and then transmit simultaneously. When this happens, both transmissions are damaged, and the stations must retransmit. The stations detect the collision and use backoff algorithms to determine when they should retransmit.

Both Ethernet and IEEE 802.3 are broadcast networks, which means that all stations see all transmissions. Each station must examine received frames to determine whether it is the intended destination. If the destination is correct, it passes the frames to a higher protocol layer for processing. IEEE 802.3 specifies several different physical layers, and Ethernet defines only one.

Each IEEE 802.3 physical layer protocol has a name that summarizes its characteristics in the format *speed/signaling method/segment length*, where *speed* is the LAN speed in Mbps, *signaling method* is the signaling method used (either *Baseband* or *Broadband*), and *segment length* is the maximum length between stations in hundreds of meters.

IEEE 802.3 10BaseT Specifications

Table 1-1 summarizes the characteristics of IEEE 802.3 Ethernet and Ethernet Version 2 for 10BaseT.

Table 1-1 *IEEE 802.3 and 10BaseT Ethernet Version 2 Physical Characteristics*

Parameter	IEEE 802.3 Ethernet	10BaseT Ethernet Version 2
Data rate (Mbps)	10	10
Signaling method	Baseband	Baseband
Maximum segment length (m)	500	100 (UTP)
Media	50-ohm coaxial (thick)	UTP
Topology	Bus	Star

Table 1-2 lists the cabling specifications for 10-Mbps transmission over UTP and foil twisted-pair (FTP) cables.

Table 1-2 *Cable Specifications for 10-Mbps 10BaseT*

Parameter	RJ-45
Cable specification	Category 5 UTP ¹ , 22 to 24 AWG ²
Maximum segment length	100 m (328 ft.) for 10BaseT
Maximum network length	200 m (656 ft) (with 1 repeater)

1. Cisco Systems does not supply Category 5 UTP RJ-45 cables; these cables are available commercially.
2. AWG = American Wire Gauge. This gauge is specified by the EIA/TIA-568 standard.



Note

The IEEE 802.3 Ethernet specifications call the PA-8E an end station, and the PA-8E has a built-in transceiver. The PA-8E interfaces connect directly to a hub or repeater.

PA-8E LEDs

The PA-8E has one status LED for each port, and an ENABLED LED, standard on all port adapters. After system initialization, the ENABLE LED lights to indicate that the PA-8E has been enabled for operation. The LEDs are shown in [Figure 1-2](#).

Figure 1-2 PA-8E LEDs—Horizontal Orientation

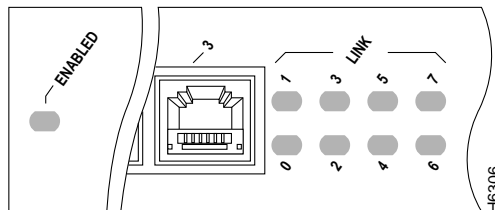

The following conditions must be met before the ENABLED LED lights:

- PA-8E is correctly connected and receiving power.
- A valid microcode version has been downloaded successfully.
- The bus recognizes the PA-8E or PA-8E-equipped VIP or Catalyst RSM/VIP2.

If any of these conditions is not met, or if the initialization fails for other reasons, the ENABLED LED does not light. When an RJ-45 port is active, its link LED lights when the PA-8E receives a carrier signal from the network.

Table 1-3 lists LED colors and indications.

Table 1-3 PA-8E LEDs

LED Label	Color	State	Meaning
ENABLED	Green	On	Port adapter is enabled for operation.
0 through 7	Red	On	Indicates port is active, receiving a carrier signal from the network.

Cables, Connectors, and Pinouts

The interface connectors on the PA-8E are eight individual RJ-45 receptacles. You can use all eight connectors simultaneously. Each connector supports IEEE 802.3 and Ethernet 10BaseT interfaces compliant with appropriate standards. The RJ-45 connectors require external transceivers. Cisco Systems does not supply Category 5 UTP RJ-45 cables; these cables are available commercially.

Figure 1-3 shows the RJ-45 connectors. Table 1-4 lists the pinouts and signals for the RJ-45 connectors.

Figure 1-3 PA-8E RJ-45 Connector—Plug and Receptacle

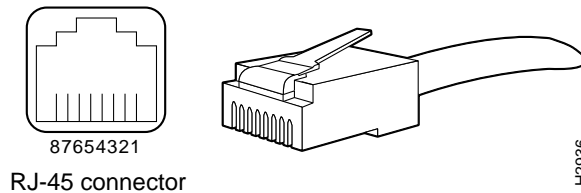

RJ-45 connector



Warning

The ports labeled “Ethernet,” “10BaseT,” “Token Ring,” “Console,” and “AUX” are safety extra-low voltage (SELV) circuits. SELV circuits should only be connected to other SELV circuits. Because the BRI circuits are treated like telephone-network voltage, avoid connecting the SELV circuit to the telephone network voltage (TNV) circuits.

Table 1-4 PA-8E RJ-45 Connector Pinout

Pin	Description
1	Transmit Data + (TxD+)
2	TxD–
3	Receive Data + (RxD+)
6	RxD–



Note

Referring to the RJ-45 pinout in Table 1-4, proper common-mode line terminations should be used for the unused Category 5, UTP cable pairs 4/5 and 7/8. Common-mode termination reduces the contributions to electromagnetic interference (EMI) and susceptibility to common-mode sources. Wire pairs 4/5 and 7/8 are actively terminated in the RJ-45 port circuitry in the PA-8E.

Depending on your PA-8E RJ-45 interface connector requirements, use the pinouts in [Figure 1-4](#) and [Figure 1-5](#).

Figure 1-4 *Straight-Through Cable Pinout—PA-8E RJ-45 Connection to a Hub or Repeater*

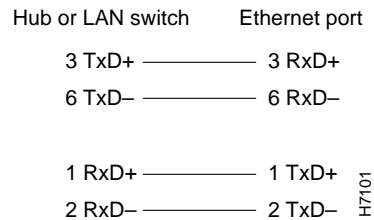
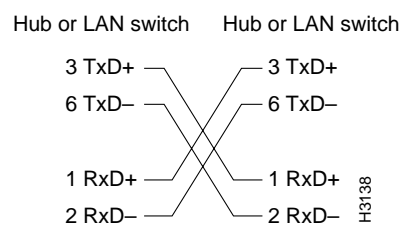

Figure 1-5 *Crossover Cable Pinout—PA-8E RJ-45 Connections Between Hubs and Repeaters*



Port Adapter Slot Locations on the Supported Platforms

This section discusses port adapter slot locations on the supported platforms. The illustrations that follow summarize slot location conventions on each platform:

- [Catalyst RSM/VIP2 Slot Numbering, page 1-7](#)
- [Cisco 7100 Series Routers Slot Numbering, page 1-8](#)
- [Cisco 7200 Series Routers and Cisco 7200 VXR Routers Slot Numbering, page 1-8](#)
- [Cisco uBR7200 Series Router Slot Numbering, page 1-9](#)
- [Cisco 7201 Router Slot Numbering, page 1-10](#)
- [Cisco 7301 Router Slot Numbering, page 1-11](#)
- [Cisco 7304 PCI Port Adapter Carrier Card Slot Numbering, page 1-11](#)
- [Cisco 7401ASR Router Slot Numbering, page 1-12](#)
- [Cisco 7000 Series Routers and Cisco 7500 Series Routers VIP Slot Numbering, page 1-13](#)

Catalyst RSM/VIP2 Slot Numbering

The Catalyst RSM/VIP2 can be installed in any slot in a Catalyst 5000 family switch except the top slots, which contain the supervisor engine modules. The Catalyst RSM/VIP2 does not use interface processor slot numbering; therefore, slots are not numbered. The PA-8E can be installed into either port adapter slot 0 or slot 1 on a Catalyst RSM/VIP2. Figure 1-6 shows a Catalyst RSM/VIP2 with two port adapters installed.



Note

The Catalyst 5500 switch has 13 slots. Slot 1 is reserved for the supervisor engine module. If a redundant supervisor engine module is used, it would go in slot 2; otherwise, slot 2 can be used for other modules. Slot 13 is a dedicated slot, reserved for the ATM Switch Processor (ASP) module. Refer to the *Catalyst 5000 Series Route Switch Module Installation and Configuration Note* for any additional slot restrictions for the Catalyst RSM/VIP2.

Figure 1-6 Catalyst 5000 Family Switch with Port Adapters Installed on Catalyst RSM/VIP2

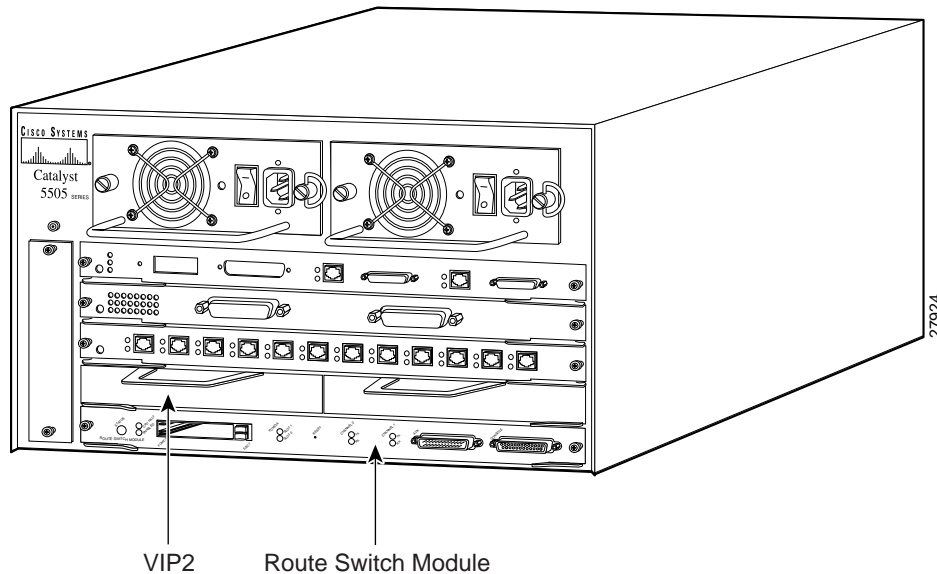

Cisco 7100 Series Routers Slot Numbering

The PA-8E can be installed in port adapter slot 3 in Cisco 7120 series routers, and in port adapter slot 4 in Cisco 7140 series routers. [Figure 1-7](#) shows the slot numbering on a Cisco 7120 series router. [Figure 1-8](#) shows the slot numbering on a Cisco 7140 series router.

Figure 1-7 Port Adapter Slots in the Cisco 7120 Series Router

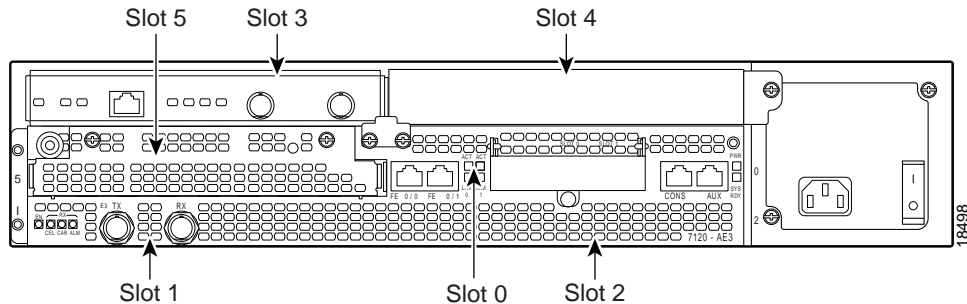
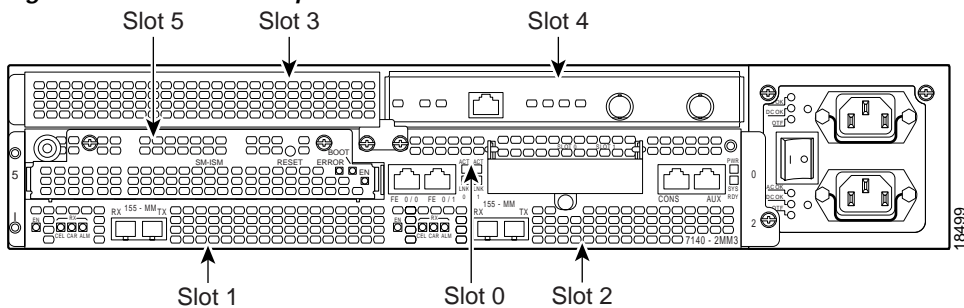

Figure 1-8 Port Adapter Slots in the Cisco 7140 Series Router



Cisco 7200 Series Routers and Cisco 7200 VXR Routers Slot Numbering

Cisco 7202 routers have two port adapter slots. The slots are numbered from left to right. You can place a port adapter in either of the slots (slot 1 or slot 2). The Cisco 7202 router is not shown.

Cisco 7204 routers and Cisco 7204VXR routers have four slots for port adapters, and one slot for an input/output (I/O) controller. The slots are numbered from the lower left to the upper right, beginning with slot 1 and continuing through slot 4. You can place a port adapter in any of the slots (slot 1 through slot 4). Slot 0 is always reserved for the I/O controller. The Cisco 7204 router and Cisco 7204VXR are not shown.

Cisco 7206 routers and Cisco 7206VXR routers (including the Cisco 7206 and Cisco 7206VXR routers as router shelves in a Cisco AS5800 Universal Access Server) have six slots for port adapters, and one slot for an input/output (I/O) controller. The slots are numbered from the lower left to the upper right, beginning with slot 1 and continuing through slot 6. You can place a port adapter in any of the six slots (slot 1 through slot 6). Slot 0 is always reserved for the I/O controller. [Figure 1-9](#) shows the slot numbering on a Cisco 7206 router. The Cisco 7206VXR router is not shown.

Figure 1-9 Port Adapter Slots in the Cisco 7206 Router

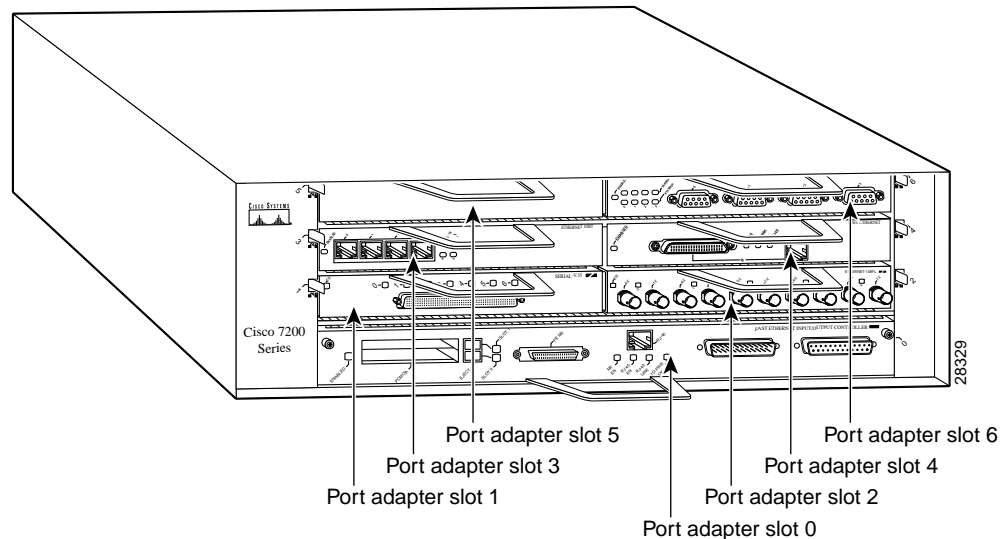

Cisco uBR7200 Series Router Slot Numbering

The Cisco uBR7223 router has one port adapter slot (slot 1). Slot 0 is always reserved for the I/O controller—if present. The Cisco uBR7223 router is not shown.

The Cisco uBR7246 router and Cisco uBR7246VXR router have two port adapter slots (slot 1 and slot 2). Slot 0 is always reserved for the I/O controller—if present. [Figure 1-10](#) shows the slot numbering of port adapters on a Cisco uBR7246 router or Cisco uBR7246VXR router.

Figure 1-10 Port Adapter Slots in the Cisco uBR7246 and Cisco uBR7246VXR Routers

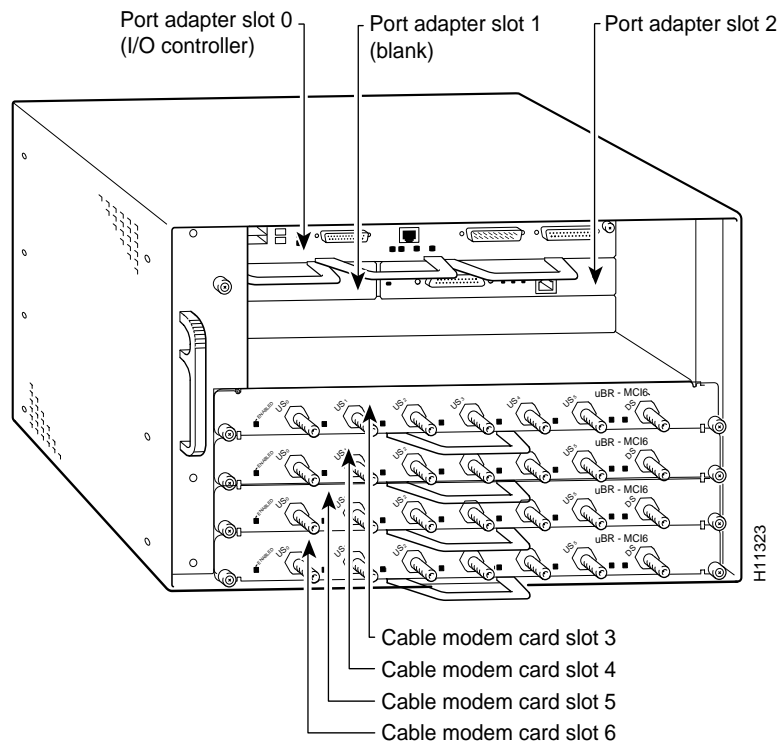

Cisco 7201 Router Slot Numbering

Figure 1-11 shows the front view of a Cisco 7201 router with a port adapter installed. There is only one port adapter slot (slot 1) in a Cisco 7201 router.

Figure 1-11 Port Adapter Slot in the Cisco 7201 Router

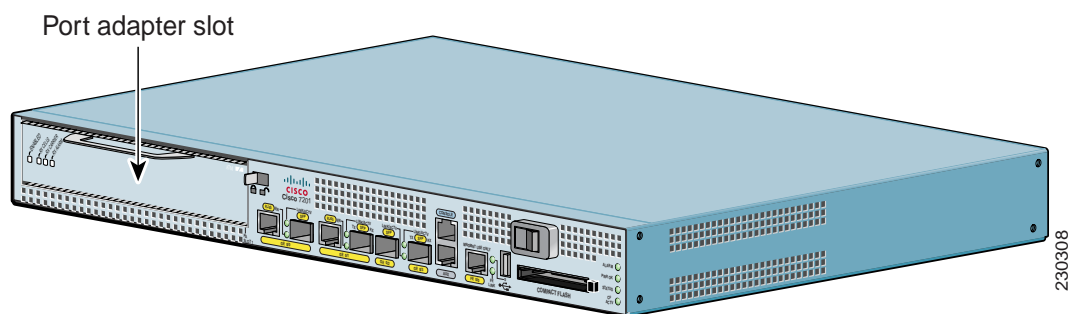

Cisco 7301 Router Slot Numbering

Figure 1-12 shows the front view of a Cisco 7301 router with a port adapter installed. There is only one port adapter slot (slot 1) in a Cisco 7301 router.

Figure 1-12 Port Adapter Slot in the Cisco 7301 Router

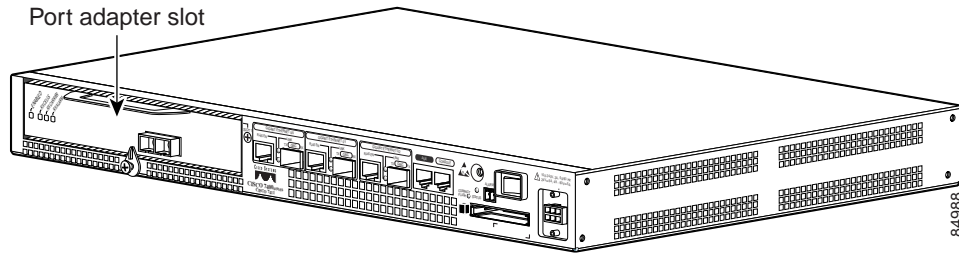

Cisco 7304 PCI Port Adapter Carrier Card Slot Numbering

The Cisco 7304 PCI Port Adapter Carrier Card installs in Cisco 7304 router module slots 2 through 5. Figure 1-13 shows a Cisco 7304 PCI Port Adapter Carrier Card with a port adapter installed. The Cisco 7304 PCI Port Adapter Carrier Card accepts one single-width port adapter.

Figure 1-14 shows the module slot numbering on a Cisco 7304 router. The port adapter slot number is the same as the module slot number. Slot 0 and slot 1 are reserved for the NPE module or NSE module.

Figure 1-13 Cisco 7304 PCI Port Adapter Carrier Card—Port Adapter Installed

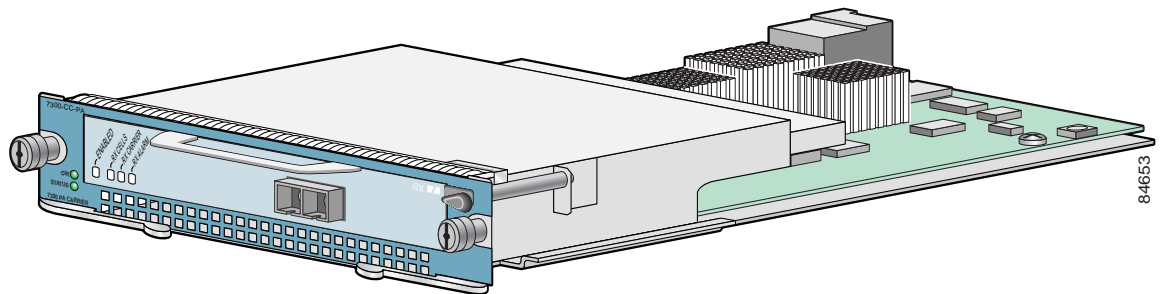
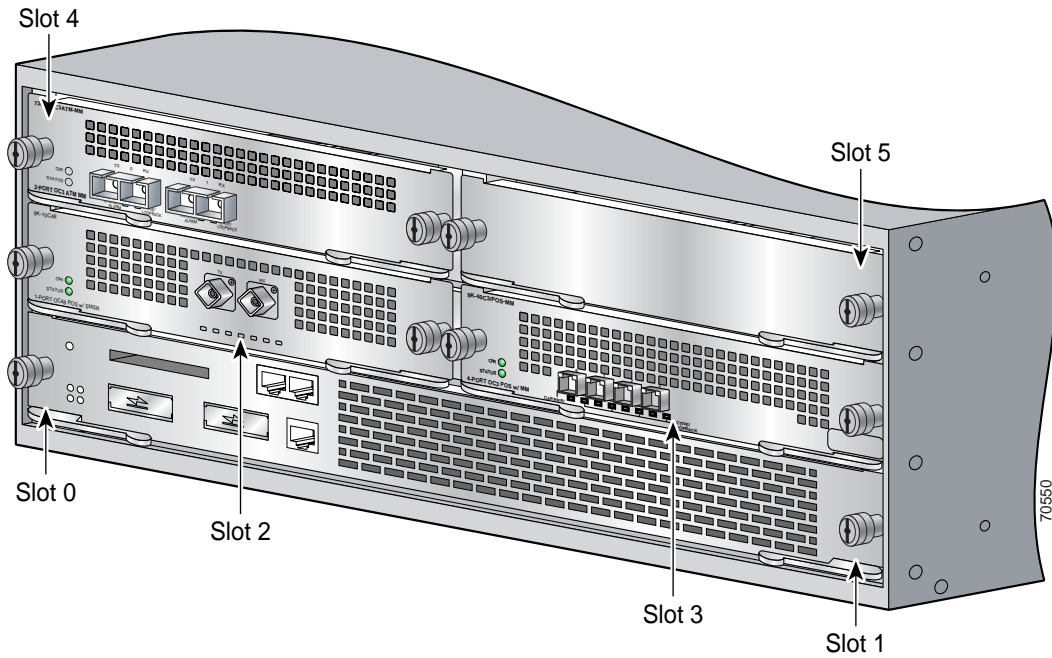

Figure 1-14 Module Slots on the Cisco 7304 Router



Cisco 7401ASR Router Slot Numbering

Figure 1-15 shows the front view of a Cisco 7401ASR router with a port adapter installed. There is only one port adapter slot (slot 1) in a Cisco 7401ASR router.

Figure 1-15 Port Adapter Slot in the Cisco 7401ASR Router

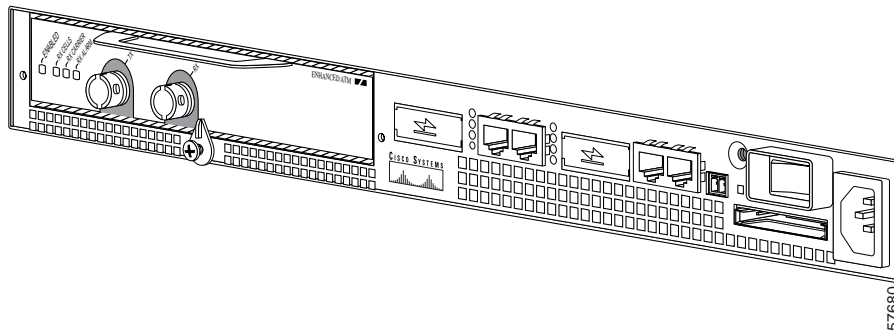

Cisco 7000 Series Routers and Cisco 7500 Series Routers VIP Slot Numbering

Port adapters are supported on the VIPs (versatile interface processors) used in Cisco 7000 series and Cisco 7500 series routers. In the Cisco 7010 router and Cisco 7505 router, the VIP motherboard is installed horizontally in the VIP slot. In the Cisco 7507 router and Cisco 7513 router, the VIP motherboard is installed vertically in the VIP slot. A port adapter can be installed in either bay (port adapter slot 0 or 1) on the VIP. The bays are numbered from left to right on the VIP. [Figure 1-16](#) shows the slot numbering on a VIP.

Figure 1-16 VIP Slot Locations—Horizontal Orientation

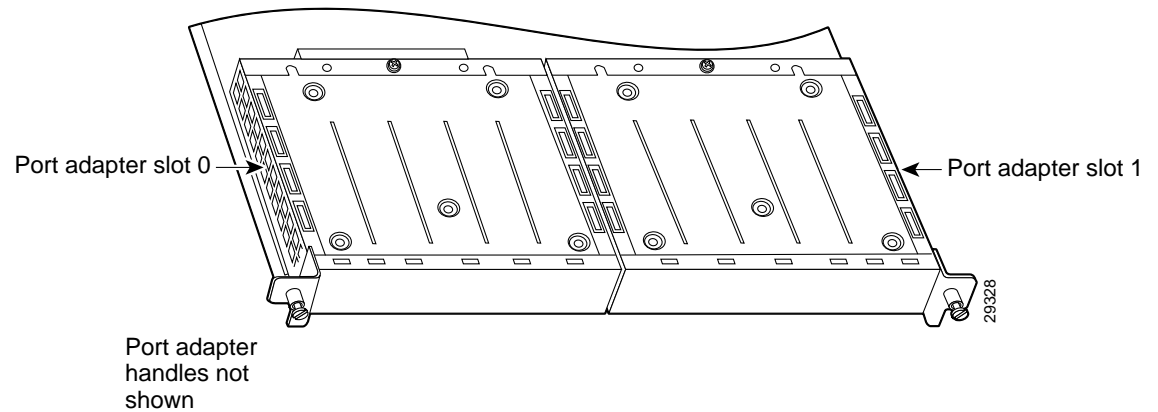

Cisco 7010 routers have three slots for port adapters, and two slots for Route Switch Processors (RSPs). The slots are numbered from bottom to top. You can place a port adapter in any of the VIP interface slots (slot 0 through 2). Slots 3 and 4 are always reserved for RSPs. The Cisco 7010 router is not shown.

Cisco 7505 routers have four slots for port adapters, and one slot for an RSP. The slots are numbered from bottom to top. You can place a port adapter in any of the VIP interface slots (slot 0 through 3). One slot is always reserved for the RSP. [Figure 1-17](#) shows the slot numbering on a Cisco 7505 router.

Figure 1-17 VIP Slots in the Cisco 7505 Router

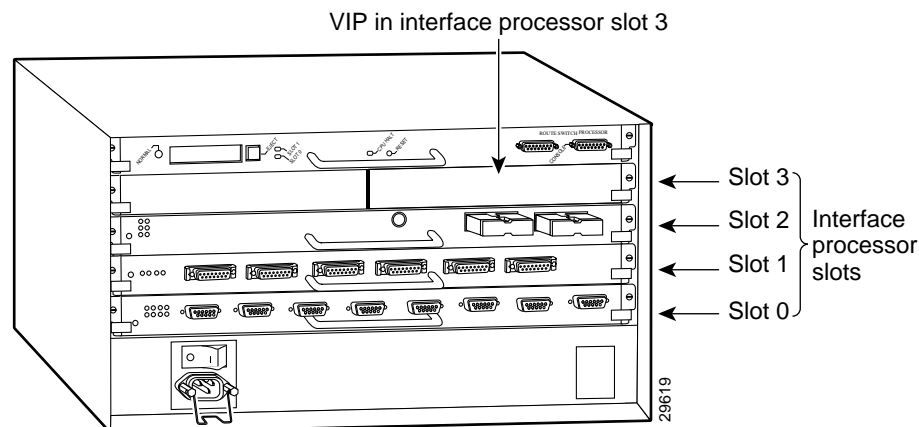

Cisco 7507 routers have five slots for port adapters, and two slots for RSPs. The slots are numbered from left to right. You can place a port adapter in any of the VIP interface slots (slot 0, 1, 4, 5, or 6). Slots 2 and 3 are always reserved for RSPs. The Cisco 7507 router is not shown.

Cisco 7513 routers have eleven slots for port adapters, and two slots for RSPs. The slots are numbered from left to right. You can place a port adapter in any of the VIP interface slots (slots 0 through 5, or slots 9 through 12). Slots 6 and 7 are always reserved for RSPs. The Cisco 7513 router is not shown.

Identifying Interface Addresses

This section describes how to identify interface addresses for the PA-8E in supported platforms. Interface addresses specify the actual physical location of each interface on a router or switch.

Interfaces on the PA-8E installed in a router maintain the same address regardless of whether other port adapters are installed or removed. However, when you move a port adapter to a different slot, the first number in the interface address changes to reflect the new port adapter slot number.

Interfaces on the PA-8E installed in a VIP or FlexWAN module maintain the same address regardless of whether other interface processors or modules are installed or removed. However, when you move a VIP or FlexWAN module to a different slot, the interface processor or module slot number changes to reflect the new interface processor or module slot.



Note

Interface ports are numbered from left to right starting with 0.

The following subsections describe the interface address formats the supported platforms:

- [Catalyst RSM/VIP2 Interface Addresses, page 1-15](#)
- [Cisco 7100 Series Routers Interface Addresses, page 1-16](#)
- [Cisco 7200 Series Routers and Cisco 7200 VXR Routers Interface Addresses, page 1-16](#)
- [Cisco uBR7200 Series Routers Interface Addresses, page 1-16](#)
- [Cisco 7201 Router Interface Addresses, page 1-16](#)
- [Cisco 7301 Router Interface Addresses, page 1-17](#)
- [Cisco 7304 PCI Port Adapter Carrier Card Interface Addresses, page 1-17](#)
- [Cisco 7401ASR Router Interface Addresses, page 1-17](#)
- [Cisco 7000 Series Routers and Cisco 7500 Series Routers VIP Interface Addresses, page 1-17](#)

Table 1-5 summarizes the interface address formats for the supported platforms.

Table 1-5 Identifying Interface Addresses

Platform	Interface Address Format	Numbers	Syntax
Catalyst RSM/VIP2 in Catalyst 5000 family switches	Port-adapter-slot-number/interface-port-number	Port adapter slot— 0 or 1 Interface port—0 through 7	0/1
Cisco 7120 series router	Port-adapter-slot-number/interface-port-number	Port adapter slot—always 3 Interface port—0 through 7	3/1
Cisco 7140 series router	Port-adapter-slot-number/interface-port-number	Port adapter slot—always 4 Interface port—0 through 7	4/0

Table 1-5 Identifying Interface Addresses (continued)

Platform	Interface Address Format	Numbers	Syntax
Cisco 7200 series routers and Cisco 7200 VXR routers	Port-adapter-slot-number/interface-port-number	Port adapter slot—1 through 6 (depends on the number of slots in the router) ¹ Interface port—0 through 7	1/0
Cisco 7201 router	Port-adapter-slot-number/interface-port-number	Port adapter slot—always 1 Interface port—0 through 7	1/0
Cisco uBR7223 router	Port-adapter-slot-number/interface-port-number	Port adapter slot—always 1 ¹ Interface port—0 through 7	1/0
Cisco uBR7246 and Cisco uBR7246VXR routers	Port-adapter-slot-number/interface-port-number	Port adapter slot—always 1 or 2 ¹ Interface port—0 through 7	1/2
Cisco 7301 router	Port-adapter-slot-number/interface-port-number	Port adapter slot—always 1 Interface port—0 through 7	1/0
Cisco 7304 PCI Port Adapter Carrier Card in Cisco 7304 routers	Module-slot-number/interface-port-number	Module slot—2 through 5 Interface port—0 through 7	3/0
Cisco 7401ASR router	Port-adapter-slot-number/interface-port-number	Port adapter slot—always 1 Interface port—0 through 7	1/0
VIP in Cisco 7000 series routers or Cisco 7500 series routers	Interface-processor-slot-number/port-adapter-slot-number/interface-port-number	Interface processor slot—0 through 12 (depends on the number of slots in the router) Port adapter slot—0 or 1 Interface port—0 through 7	3/1/0

1. Port adapter slot 0 is reserved for the Fast Ethernet port on the I/O controller (if present).

Catalyst RSM/VIP2 Interface Addresses

In Catalyst 5000 family switches, the Catalyst RSM/VIP2 can be installed in any slot except the top slots, which contain the supervisor engine modules. The Catalyst RSM/VIP2 in a Catalyst 5000 family switch does not use interface processor slot numbering; therefore, the slots in which it is installed are not numbered. A port adapter can be installed into either port adapter slot 0 or slot 1 on a Catalyst RSM/VIP2. See [Figure 1-5](#).

The interface address is composed of a two-part number in the format *port-adapter-slot number/interface-port number*. See [Table 1-5](#). For example, if the eight-port PA-8E is installed in a VIP in interface processor slot 1, port adapter slot 1, the interface addresses would be 1/1/0, 1/1/1, 1/1/2, 1/1/3, 1/1/4, 1/1/5, 1/1/6, and 1/1/7 (interface processor slot 1, port adapter slot 1, and interfaces 0, 1, 2, 3, 4, 5, 6, and 7).

Cisco 7100 Series Routers Interface Addresses

In Cisco 7120 series router, port adapters are installed in port adapter slot 3. See [Figure 1-7](#). In the Cisco 7140 series router, port adapters are installed in port adapter slot 4. See [Figure 1-8](#).

The interface address is composed of a two-part number in the format *port-adapter-slot-number/interface-port-number*. See [Table 1-5](#). For example, if an eight-port PA-8E is installed on a Cisco 7120 router, the interface addresses would be 3/0 through 3/7 (port adapter slot 3, and interfaces 0,1, 2, 3, 4, 5, 6, and 7). If an eight-port PA-8E is installed on a Cisco 7140 router, the interface addresses would be 4/0 through 4/7 (port adapter slot 4, and interfaces 0,1, 2, 3, 4, 5, 6, and 7).

Cisco 7200 Series Routers and Cisco 7200 VXR Routers Interface Addresses

In Cisco 7200 series routers and Cisco 7200 VXR routers, port adapter slots are numbered from the lower left to the upper right, beginning with slot 1 and continuing through slot 2 for the Cisco 7202, slot 4 for the Cisco 7204 and Cisco 7204VXR, and slot 6 for the Cisco 7206 and Cisco 7206VXR. Port adapters can be installed in any available port adapter slot from 1 through 6 (depending on the number of slots in the router). (Slot 0 is reserved for the I/O controller.) See [Figure 1-9](#).

The interface address is composed of a two-part number in the format *port-adapter-slot-number/interface-port-number*. See [Table 1-5](#). For example, if an eight-port PA-8E is installed in slot 1 of a Cisco 7200 series router, the interface addresses would be 1/0 through 1/7 (port adapter slot 1 and interfaces 0 through 7).

Cisco uBR7200 Series Routers Interface Addresses

In the Cisco uBR7223 router, only one slot accepts port adapters and it is numbered slot 1.

In the Cisco uBR7246 router and Cisco uBR7246VXR router, port adapters can be installed in two port adapter slots (slot1 and slot 2). Slot 0 is always reserved for the I/O controller—if present. See [Figure 1-10](#).

The interface address is composed of a two-part number in the format *port-adapter-slot-number/interface-port-number*. See [Table 1-5](#). For example, if an eight-port PA-8E is installed in slot 1 of a Cisco uBR7223 series router, the interface addresses would be 1/0 through 1/7. If an eight-port PA-8E is installed in slot 2 of a Cisco uBR7246 or Cisco uBR7246VXR router, the interface addresses would be 2/0 through 2/7.

Cisco 7201 Router Interface Addresses

In the Cisco 7201 router, only one slot accepts port adapters and it is numbered as slot 1. See [Figure 1-11](#).

The interface address is composed of a two-part number in the format *port-adapter-slot-number/interface-port-number*. See [Table 1-5](#). For example, if an eight-port PA-8E is installed in a Cisco 7201 router, the interface addresses would be 1/0 through 1/7.

Cisco 7301 Router Interface Addresses

In the Cisco 7301 router, only one slot accepts port adapters and it is numbered as slot 1. See [Figure 1-12](#).

The interface address is composed of a two-part number in the format *port-adapter-slot-number/interface-port-number*. See [Table 1-5](#). For example, if an eight-port PA-8E is installed in a Cisco 7301 router, the interface addresses would be 1/0 through 1/7.

Cisco 7304 PCI Port Adapter Carrier Card Interface Addresses

In the Cisco 7304 router, port adapters are installed in a Cisco 7304 PCI port adapter carrier card, which installs in Cisco 7304 router module slots 2 through 5. The port adapter slot number is the same as the module slot number. See [Figure 1-13](#) and [Figure 1-14](#).

The interface address is composed of a two-part number in the format *module-slot-number/interface-port-number*. See [Table 1-5](#). For example, if an eight-port PA-8E is installed in the Cisco 7304 PCI port adapter carrier card in Cisco 7304 router module slot 3, the interface addresses would be 3/0 through 3/7.

Cisco 7401ASR Router Interface Addresses

In the Cisco 7401ASR router, only one slot accepts port adapters and it is numbered as slot 1. See [Figure 1-15](#).

The interface address is composed of a two-part number in the format *port-adapter-slot-number/interface-port-number*. See [Table 1-5](#). For example, if an eight-port PA-8E is installed in a Cisco 7401ASR router, the interface addresses would be 1/0 through 1/7.

Cisco 7000 Series Routers and Cisco 7500 Series Routers VIP Interface Addresses

In Cisco 7000 series routers and Cisco 7500 series routers, port adapters are installed on a versatile interface processor (VIP), which installs in interface processor slots 0 through 12 (depending on the number of slots in the router). The port adapter can be installed in either bay (port adapter slot 0 or 1) on the VIP. See [Figure 1-16](#) and [Figure 1-17](#).

The interface address for the VIP is composed of a three-part number in the format *interface-processor-slot-number/port-adapter-slot-number/interface-port-number*. See [Table 1-5](#).

The first number identifies the slot in which the VIP is installed (slot 0 through 12, depending on the number of slots in the router).

The second number identifies the bay (port adapter slot) on the VIP in which the port adapter is installed (0 or 1). The bays are numbered from left to right on the VIP.

The third number identifies the physical port number (interface port number) on the port adapter. The port numbers always begin at 0 and are numbered from left to right. The number of additional ports depends on the number of ports on the port adapter. The PA-8E is an eight-port port adapter, therefore the port can be 0 through 7.

For example, if an eight-port PA-8E is installed in a VIP in interface processor slot 3, port adapter slot 1, the interface addresses would be 3/1/0 through 3/1/7 (interface processor slot 3, port adapter slot 1, and interfaces 0, 1, 2, 3, 4, 5, 6, and 7).

**Note**

Although the processor slots in the 7-slot Cisco 7000 and Cisco 7507 and the 13-slot Cisco 7513 and Cisco 7576 are vertically oriented and those in the 5-slot Cisco 7010 and Cisco 7505 are horizontally oriented, all Cisco 7000 series and Cisco 7500 series routers use the same method for slot and port numbering.



CHAPTER 2

Preparing for Installation

This chapter describes the general equipment, safety, and site preparation requirements for installing the PA-8E. The chapter contains the following sections:

- [Required Parts and Tools, page 2-1](#)
- [Software and Hardware Requirements, page 2-2](#)
- [Checking Hardware and Software Compatibility, page 2-3](#)
- [Safety Guidelines, page 2-4](#)
- [FCC Class B Compliance, page 2-10](#)

Required Parts and Tools

You need the following tools and parts to install the PA-8E. If you need additional equipment, contact a service representative for ordering information.

- PA-8E
- Cables appropriate for the port adapter interfaces (RJ-45 cables are not available from Cisco Systems; they are available from outside commercial cable vendors)
- Number 1 Phillips and a 3/16-inch, flat-blade screwdriver (for VIP and Catalyst RSM/VIP2)
- Number 2 Phillips screwdriver
- Your own electrostatic discharge (ESD)-prevention equipment or the disposable grounding wrist strap included with all upgrade kits, field-replaceable units (FRUs), and spares
- Antistatic mat
- Antistatic container

Software and Hardware Requirements

Table 2-1 lists the minimum Cisco IOS software release required to use the PA-8E in supported router platforms.

Table 2-1 PA-8E Software Requirements

Platform	Recommended Minimum Cisco IOS Release
Catalyst 5000 family switches <ul style="list-style-type: none"> With Catalyst RSM/VIP2-15(=) or Catalyst RSM/VIP2-40(=) 	Cisco IOS Release 11.2(15)P or a later release of Cisco IOS Release 11.2P
Cisco 7000 and Cisco 7500 series routers <ul style="list-style-type: none"> With VIP2-15(=) or VIP2-40(=) With VIP2-50(=) With VIP4-50(=) With VIP4-80(=) With VIP6-80(=) 	Cisco IOS Release 11.1(472) or a later release of Cisco IOS Release 11.1 Cisco IOS Release 11.1(14)CA or a later release of Cisco IOS Release 11.1CA Cisco IOS Release 12.2(2)T or a later release of Cisco IOS Release 12.2T Cisco IOS Release 12.2(2)T or a later release of Cisco IOS Release 12.2T Cisco IOS Release 12.1(12)E or a later release of Cisco IOS Release 12.1E
Cisco 7100 series routers <ul style="list-style-type: none"> Cisco 7120 series and Cisco 7140 series 	Cisco IOS Release 12.0(4)XE or a later release of Cisco IOS Release 12.0XE Cisco IOS Release 12.0(5)T or a later release of Cisco IOS Release 12.0
Cisco 7200 series and Cisco 7200 VXR routers <ul style="list-style-type: none"> Cisco 7204 and Cisco 7206 Cisco 7204VXR and Cisco 7206VXR Cisco 7202 	Cisco IOS Release 11.1(472) or a later release of Cisco IOS Release 11.1 Cisco IOS Release 12.2(4)B or a later release of Cisco IOS Release 12.2B Cisco IOS Release 12.0(2)XE2 or a later release of Cisco IOS Release 12.0XE Cisco IOS Release 12.0(3)T or a later release of Cisco IOS Release 12.0T Cisco IOS Release 12.2(4)B or a later release of Cisco IOS Release 12.2B Cisco IOS Release 11.1(19)CC1 or a later release of Cisco IOS Release 11.1CC Cisco IOS Release 11.3(4)AA or a later release of Cisco IOS Release 11.3AA Cisco IOS Release 12.2(4)B or a later release of Cisco IOS Release 12.2B
Cisco uBR7200 series routers <ul style="list-style-type: none"> Cisco uBR7246, Cisco uBR7246 VXR, and Cisco uBR7223 	Cisco IOS Release 11.3(7)NA or a later release of Cisco IOS Release 11.3NA Cisco IOS Release 12.0(3)T or a later release of Cisco IOS Release 12.0T Cisco IOS Release 12.0(7)SC or a later release of Cisco IOS Release 12.0SC Cisco IOS Release 12.0(7)XR or a later release of Cisco IOS Release 12.0XR
Cisco 7201 router	Cisco IOS Release 12.4(4)XD7 or a later release of Cisco IOS Release 12.4XD Cisco IOS Release 12.2(31)SB5 or a later release of Cisco IOS Release 12.2SB
Cisco 7301 router	Cisco IOS Release 12.2(11)YZ or a later release of Cisco IOS Release 12.2YZ
Cisco 7304 router <ul style="list-style-type: none"> With Cisco 7304 PCI Port Adapter Carrier Card 	Cisco IOS Release 12.2(14)SZ or a later release of Cisco IOS Release 12.2SZ
Cisco 7401ASR router	Cisco IOS Release 12.2(1)DX or a later release of Cisco IOS Release 12.2DX Cisco IOS Release 12.2(4)B or a later release of Cisco IOS Release 12.2B

**Note**

For Cisco 7200 series port adapter hardware and memory configuration guidelines, refer to the document *Cisco 7200 Series Port Adapter Hardware Configuration Guidelines* at the following URL:
http://www.cisco.com/en/US/products/hw/modules/ps2033/products_configuration_guide_book09186a00801056ef.html.

**Caution**

The VIP2 or VIP4 requires that a Cisco 7000 series router has the RSP7000 and RSP7000CI installed. The VIP2 or VIP4 will *not* operate properly with the Route Processor (RP), Switch Processor (SP), or Silicon Switch Processor (SSP) installed in a Cisco 7000 series router.

**Note**

Port adapters used with the Cisco 7200 VXR and Cisco uBR7246 VXR routers require the correct base hardware revision to function. The following error message will occur on bootup if the incorrect hardware revision is used:

```
PA-3-REVNOTSUPPORTED:PA in slot 1 (Ethernet) requires base h/w revision of (1.14) for this chassis
```

Use the **show diag** command to display the hardware revision.

Checking Hardware and Software Compatibility

To check the minimum software requirements of Cisco IOS software with the hardware installed on your router, Cisco maintains the Software Advisor tool on Cisco.com. This tool does not verify whether modules within a system are compatible, but it does provide the minimum IOS requirements for individual hardware modules or components.

**Note**

Access to this tool is limited to users with Cisco.com login accounts.

To access Software Advisor, click **Log In** at Cisco.com and go to Support > Tools and Resources. You can also access the tool by pointing your browser directly to
http://www.cisco.com/en/US/support/tsd_most_requested_tools.html.

Choose a product family or enter a specific product number to search for the minimum supported software release needed for your hardware.

Safety Guidelines

Following are safety guidelines that you should follow when working with any equipment that connects to electrical power or telephone wiring.

Safety Warnings

Safety warnings appear throughout this publication in procedures that, if performed incorrectly, may harm you. A warning symbol precedes each warning statement.



Warning

IMPORTANT SAFETY INSTRUCTIONS

This warning symbol means danger. You are in a situation that could cause bodily injury. Before you work on any equipment, be aware of the hazards involved with electrical circuitry and be familiar with standard practices for preventing accidents. To see translations of the warnings that appear in this publication, refer to the translated safety warnings that accompanied this device.

Note: SAVE THESE INSTRUCTIONS

Note: This documentation is to be used in conjunction with the specific product installation guide that shipped with the product. Please refer to the Installation Guide, Configuration Guide, or other enclosed additional documentation for further details.

Waarschuwing

BELANGRIJKE VEILIGHEIDSINSTRUCTIES

Dit waarschuwingssymbool betekent gevaar. U verkeert in een situatie die lichamelijk letsel kan veroorzaken. Voordat u aan enige apparatuur gaat werken, dient u zich bewust te zijn van de bij elektrische schakelingen betrokken risico's en dient u op de hoogte te zijn van de standaard praktijken om ongelukken te voorkomen. Voor een vertaling van de waarschuwingen die in deze publicatie verschijnen, dient u de vertaalde veiligheidswaarschuwingen te raadplegen die bij dit apparaat worden geleverd.

Opmerking BEWAAR DEZE INSTRUCTIES.

Opmerking Deze documentatie dient gebruikt te worden in combinatie met de installatiehandleiding voor het specifieke product die bij het product wordt geleverd. Raadpleeg de installatiehandleiding, configuratiehandleiding of andere verdere ingesloten documentatie voor meer informatie.

Varoitus

TÄRKEITÄ TURVALLISUUTEEN LIITTYVIÄ OHJEITA

Tämä varoitusmerkki merkitsee vaaraa. Olet tilanteessa, joka voi johtaa ruumiinvammaan. Ennen kuin työskentelet minkään laitteiston parissa, ota selvää sähkökytkentöihin liittyvistä vaaroista ja tavanomaisista onnettomuuksien ehkäisykeinoista. Tässä asiakirjassa esitettyjen varoitusten käännökset löydät laitteen mukana toimitetuista ohjeista.

Huomautus SÄILYTÄ NÄMÄ OHJEET

Huomautus Tämä asiakirja on tarkoitettu käytettäväksi yhdessä tuotteen mukana tulleen asennusoppaan kanssa. Katso lisätietoja asennusoppaasta, kokoonpano-oppaasta ja muista mukana toimitetuista asiakirjoista.

Attention **IMPORTANTES INFORMATIONS DE SÉCURITÉ**

Ce symbole d'avertissement indique un danger. Vous vous trouvez dans une situation pouvant causer des blessures ou des dommages corporels. Avant de travailler sur un équipement, soyez conscient des dangers posés par les circuits électriques et familiarisez-vous avec les procédures couramment utilisées pour éviter les accidents. Pour prendre connaissance des traductions d'avertissements figurant dans cette publication, consultez les consignes de sécurité traduites qui accompagnent cet appareil.

Remarque **CONSERVEZ CES INFORMATIONS**

Remarque Cette documentation doit être utilisée avec le guide spécifique d'installation du produit qui accompagne ce dernier. Veuillez vous reporter au Guide d'installation, au Guide de configuration, ou à toute autre documentation jointe pour de plus amples renseignements.

Warnung **WICHTIGE SICHERHEITSANWEISUNGEN**

Dieses Warnsymbol bedeutet Gefahr. Sie befinden sich in einer Situation, die zu einer Körperverletzung führen könnte. Bevor Sie mit der Arbeit an irgendeinem Gerät beginnen, seien Sie sich der mit elektrischen Stromkreisen verbundenen Gefahren und der Standardpraktiken zur Vermeidung von Unfällen bewusst. Übersetzungen der in dieser Veröffentlichung enthaltenen Warnhinweise sind im Lieferumfang des Geräts enthalten.

Hinweis **BEWAHREN SIE DIESE SICHERHEITSANWEISUNGEN AUF**

Hinweis Dieses Handbuch ist zum Gebrauch in Verbindung mit dem Installationshandbuch für Ihr Gerät bestimmt, das dem Gerät beiliegt. Entnehmen Sie bitte alle weiteren Informationen dem Handbuch (Installations- oder Konfigurationshandbuch o. Ä.) für Ihr spezifisches Gerät.

Figyelem! **FONTOS BIZTONSÁGI ELŐÍRÁSOK**

Ez a figyelmeztető jel veszélyre utal. Sérülésveszélyt rejtő helyzetben van. Mielőtt bármely berendezésen munkát végezte, legyen figyelemmel az elektromos áramkörök okozta kockázatokra, és ismerkedjen meg a szokásos balesetvédelmi eljárásokkal. A kiadványban szereplő figyelmeztetések fordítása a készülékhez mellékelt biztonsági figyelmeztetések között található.

Megjegyzés **ŐRIZZE MEG EZEKET AZ UTASÍTÁSOKAT!**

Megjegyzés Ezt a dokumentációt a készülékhez mellékelt üzembe helyezési útmutatóval együtt kell használni. További tudnivalók a mellékelt Üzembe helyezési útmutatóban (Installation Guide), Konfigurációs útmutatóban (Configuration Guide) vagy más dokumentumban található.

Avvertenza **IMPORTANTI ISTRUZIONI SULLA SICUREZZA**

Questo simbolo di avvertenza indica un pericolo. La situazione potrebbe causare infortuni alle persone. Prima di intervenire su qualsiasi apparecchiatura, occorre essere al corrente dei pericoli relativi ai circuiti elettrici e conoscere le procedure standard per la prevenzione di incidenti. Per le traduzioni delle avvertenze riportate in questo documento, vedere le avvertenze di sicurezza che accompagnano questo dispositivo.

Nota **CONSERVARE QUESTE ISTRUZIONI**

Nota La presente documentazione va usata congiuntamente alla guida di installazione specifica spedita con il prodotto. Per maggiori informazioni, consultare la Guida all'installazione, la Guida alla configurazione o altra documentazione acclusa.

Advarsel VIKTIGE SIKKERHETSINSTRUKSJONER

Dette varselssymbolet betyr fare. Du befinner deg i en situasjon som kan forårsake personskade. Før du utfører arbeid med utstyret, bør du være oppmerksom på farene som er forbundet med elektriske kretssystemer, og du bør være kjent med vanlig praksis for å unngå ulykker. For å se oversettelser av advarslene i denne publikasjonen, se de oversatte sikkerhetsvarslene som følger med denne enheten.

Merk TA VARE PÅ DISSE INSTRUKSJONENE

Merk Denne dokumentasjonen skal brukes i forbindelse med den spesifikke installasjonsveiledningen som fulgte med produktet. Vennligst se installasjonsveiledningen, konfigureringsveiledningen eller annen vedlagt tilleggsdokumentasjon for detaljer.

Aviso INSTRUÇÕES IMPORTANTES DE SEGURANÇA

Este símbolo de aviso significa perigo. O utilizador encontra-se numa situação que poderá ser causadora de lesões corporais. Antes de iniciar a utilização de qualquer equipamento, tenha em atenção os perigos envolvidos no manuseamento de circuitos eléctricos e familiarize-se com as práticas habituais de prevenção de acidentes. Para ver traduções dos avisos incluídos nesta publicação, consulte os avisos de segurança traduzidos que acompanham este dispositivo.

Nota GUARDE ESTAS INSTRUÇÕES

Nota Esta documentação destina-se a ser utilizada em conjunto com o manual de instalação incluído com o produto específico. Consulte o manual de instalação, o manual de configuração ou outra documentação adicional inclusa, para obter mais informações.

¡Advertencia! INSTRUCCIONES IMPORTANTES DE SEGURIDAD

Este símbolo de aviso indica peligro. Existe riesgo para su integridad física. Antes de manipular cualquier equipo, considere los riesgos de la corriente eléctrica y familiarícese con los procedimientos estándar de prevención de accidentes. Vea las traducciones de las advertencias que acompañan a este dispositivo.

Nota GUARDE ESTAS INSTRUCCIONES

Nota Esta documentación está pensada para ser utilizada con la guía de instalación del producto que lo acompaña. Si necesita más detalles, consulte la Guía de instalación, la Guía de configuración o cualquier documentación adicional adjunta.

Varning! VIKTIGA SÄKERHETSANVISNINGAR

Denna varningssignal signalerar fara. Du befinner dig i en situation som kan leda till personskada. Innan du utför arbete på någon utrustning måste du vara medveten om farorna med elkretsar och känna till vanliga förfaranden för att förebygga olyckor. Se översättningarna av de varningsmeddelanden som finns i denna publikation, och se de översatta säkerhetsvarningarna som medföljer denna anordning.

OBS! SPARA DESSA ANVISNINGAR

OBS! Denna dokumentation ska användas i samband med den specifika produktinstallationshandbok som medföljde produkten. Se installationshandboken, konfigurationshandboken eller annan bifogad ytterligare dokumentation för närmare detaljer.

Предупреждение **ВАЖНЫЕ СВЕДЕНИЯ ПО БЕЗОПАСНОСТИ**

Этот символ предупреждает о наличии опасности. При неправильных действиях возможно получение травм. Перед началом работы с любым оборудованием необходимо ознакомиться с ситуациями, в которых возможно поражение электротоком, и со стандартными действиями для предотвращения несчастных случаев. Переведенный текст предупреждений содержится в соответствующем документе, поставляемом вместе с устройством.

Примечание **СОХРАНЯЙТЕ ЭТУ ИНСТРУКЦИЮ**

Примечание Эта инструкция должна использоваться вместе с руководством по установке конкретного изделия, входящим в комплект поставки. Дополнительные сведения см. в руководстве по установке, руководстве по настройке и другой документации, поставляемой с изделием.

警告 有关安全的重要说明

这个警告符号指有危险。您所处的环境可能使身体受伤。操作设备前必须意识到电流的危险性，务必熟悉操作标准，以防发生事故。如果需要了解本说明中出现的警告符号的译文，请参阅本装置所附之安全警告译文。

注意 保存这些说明

注意 本文件应与本产品附带的具体安装说明一并阅读。如欲了解详情，请参阅《安装说明》、《配置说明》或所附的其他文件。

警告 安全上の重要な注意事項

「危険」の意味です。人身事故を予防するための注意事項が記述されています。装置の取り扱い作業を行うときは、電気回路の危険性に注意し、一般的な事故防止対策に留意してください。このマニュアルに記載されている警告の各国語版は、装置に付属の「Translated Safety Warnings」を参照してください。

注 これらの注意事項を保管しておいてください。

注 この資料は、製品に付属のインストレーション ガイドと併用してください。詳細は、インストレーション ガイド、コンフィギュレーション ガイド、または添付されているその他のマニュアルを参照してください。

Предупреждение **ВАЖНЫЕ СВЕДЕНИЯ ПО БЕЗОПАСНОСТИ**

Этот символ предупреждает о наличии опасности. При неправильных действиях возможно получение травм. Перед началом работы с любым оборудованием необходимо ознакомиться с ситуациями, в которых возможно поражение электротоком, и со стандартными действиями для предотвращения несчастных случаев. Переведенный текст предупреждений содержится в соответствующем документе, поставляемом вместе с устройством.

Примечание **СОХРАНЯЙТЕ ЭТУ ИНСТРУКЦИЮ**

Примечание Эта инструкция должна использоваться вместе с руководством по установке конкретного изделия, входящим в комплект поставки. Дополнительные сведения см. в руководстве по установке, руководстве по настройке и другой документации, поставляемой с изделием.

警告 有关安全的重要说明

这个警告符号指有危险。您所处的环境可能使身体受伤。操作设备前必须意识到电流的危险性，务必熟悉操作标准，以防发生事故。如果需要了解本说明中出现的警告符号的译文，请参阅本装置所附之安全警告译文。

注意 保存这些说明

注意 本文件应与本产品附带的具体安装说明一并阅读。如欲了解详情，请参阅《安装说明》、《配置说明》或所附的其他文件。

警告 安全上の重要な注意事項

「危険」の意味です。人身事故を予防するための注意事項が記述されています。装置の取り扱い作業を行うときは、電気回路の危険性に注意し、一般的な事故防止対策に留意してください。このマニュアルに記載されている警告の各国語版は、装置に付属の「Translated Safety Warnings」を参照してください。

注 これらの注意事項を保管しておいてください。

注 この資料は、製品に付属のインストレーション ガイドと併用してください。詳細は、インストレーション ガイド、コンフィギュレーション ガイド、または添付されているその他のマニュアルを参照してください。

Electrical Equipment Guidelines

Follow these basic guidelines when working with any electrical equipment:

- Before beginning any procedures requiring access to the chassis interior, locate the emergency power-off switch for the room in which you are working.
- Disconnect all power and external cables before moving a chassis; do not work alone when potentially hazardous conditions exist.
- Never assume that power has been disconnected from a circuit; always check.
- Do not perform any action that creates a potential hazard to people or makes the equipment unsafe; carefully examine your work area for possible hazards such as moist floors, ungrounded power extension cables, and missing safety grounds.

Telephone Wiring Guidelines

Use the following guidelines when working with any equipment that is connected to telephone wiring or to other network cabling:

- Never install telephone wiring during a lightning storm.
- Never install telephone jacks in wet locations unless the jack is specifically designed for wet locations.
- Never touch uninsulated telephone wires or terminals unless the telephone line has been disconnected at the network interface.
- Use caution when installing or modifying telephone lines.

Preventing Electrostatic Discharge Damage

Electrostatic discharge (ESD) damage, which can occur when electronic cards or components are improperly handled, results in complete or intermittent failures. Port adapters and processor modules comprise printed circuit boards that are fixed in metal carriers. Electromagnetic interference (EMI) shielding and connectors are integral components of the carrier. Although the metal carrier helps to protect the board from ESD, use a preventive antistatic strap during handling.

Following are guidelines for preventing ESD damage:

- Always use an ESD wrist or ankle strap and ensure that it makes good skin contact.
- Connect the equipment end of the strap to an unfinished chassis surface.
- When installing a component, use any available ejector levers or captive installation screws to properly seat the bus connectors in the backplane or midplane. These devices prevent accidental removal, provide proper grounding for the system, and help to ensure that bus connectors are properly seated.
- When removing a component, use any available ejector levers or captive installation screws to release the bus connectors from the backplane or midplane.
- Handle carriers by available handles or edges only; avoid touching the printed circuit boards or connectors.
- Place a removed board component-side-up on an antistatic surface or in a static shielding container. If you plan to return the component to the factory, immediately place it in a static shielding container.

- Avoid contact between the printed circuit boards and clothing. The wrist strap only protects components from ESD voltages on the body; ESD voltages on clothing can still cause damage.
- Never attempt to remove the printed circuit board from the metal carrier.

**Caution**

For safety, periodically check the resistance value of the antistatic strap. The measurement should be between 1 and 10 megohms (Mohm).

FCC Class B Compliance

The equipment described in this manual generates and may radiate radio-frequency energy. If it is not installed in accordance with Cisco's installation instructions, it may cause interference with radio and television reception. This equipment has been tested and found to comply with the limits for a Class B digital device in accordance with the specifications in part 15 of the FCC rules. These specifications are designed to provide reasonable protection against such interference in a residential installation. However, there is no guarantee that interference will not occur in a particular installation.

You can determine whether your equipment is causing interference by turning it off. If the interference stops, it was probably caused by the Cisco equipment or one of its peripheral devices. If the equipment causes interference to radio or television reception, try to correct the interference by using one or more of the following measures:

- Turn the television or radio antenna until the interference stops.
- Move the equipment to one side or the other of the television or radio.
- Move the equipment farther away from the television or radio.
- Plug the equipment into an outlet that is on a different circuit from the television or radio. (That is, make certain the equipment and the television or radio are on circuits controlled by different circuit breakers or fuses.)

Modifications to this product not authorized by Cisco Systems, Inc. could void the FCC approval and negate your authority to operate the product.



CHAPTER 3

Removing and Installing Port Adapters

This chapter describes how to remove the PA-8E from supported platforms and also how to install a new or replacement port adapter. This chapter contains the following sections:

- [Handling Port Adapters, page 3-1](#)
- [Online Insertion and Removal, page 3-2](#)
- [Warnings and Cautions, page 3-3](#)
- [Port Adapter Removal and Installation, page 3-4](#)
- [Connecting PA-8E Interface Cables, page 3-16](#)

Handling Port Adapters

Each port adapter circuit board is mounted to a metal carrier and is sensitive to electrostatic discharge (ESD) damage.



Note

When a port adapter slot is not in use, a blank port adapter must fill the empty slot to allow the router or switch to conform to electromagnetic interference (EMI) emissions requirements and to allow proper airflow across the port adapters. If you plan to install a new port adapter in a slot that is not in use, you must first remove the blank port adapter.



Caution

When powering off the router, wait a minimum of 30 seconds before powering it on again.



Caution

Always handle the port adapter by the carrier edges and handle; never touch the port adapter components or connector pins. (See [Figure 3-1](#).)

Figure 3-1 Handling a Port Adapter

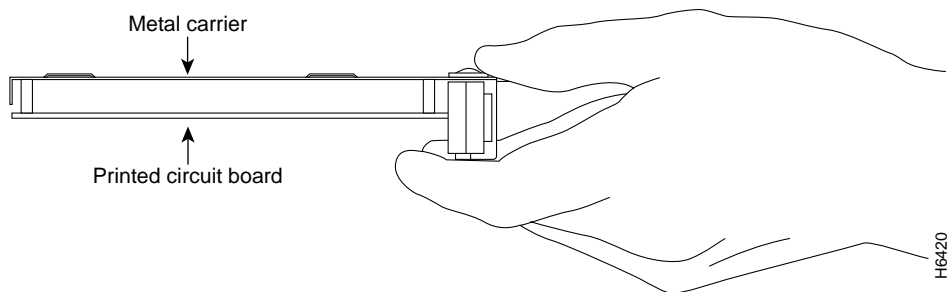

Online Insertion and Removal

Several platforms support online insertion and removal (OIR) of port adapters; therefore, you do not have to power down routers when removing and replacing a PA-8E in the Cisco 7100 series routers, Cisco 7200 series routers, Cisco 7200 VXR routers, Cisco uBR7200 series routers, Cisco 7201 router, Cisco 7301 router, or Cisco 7401ASR router.

Although the Catalyst RSM/VIP2, Cisco 7304 PCI port adapter carrier card, and VIP support online insertion and removal, individual port adapters do not. To replace port adapters, you must first remove the Catalyst RSM/VIP2, Cisco 7304 PCI port adapter carrier card, or VIP from the router and then install or replace port adapters as required. If a blank port adapter is installed on the Catalyst RSM/VIP2, Cisco 7304 PCI port adapter carrier card, or VIP on which you want to install a new port adapter, you must first remove the Catalyst RSM/VIP2, Cisco 7304 PCI port adapter carrier card, or VIP from the router and then remove the blank port adapter.



Caution

To prevent system problems, do not remove port adapters from the Catalyst RSM/VIP2, Cisco 7304 PCI port adapter carrier card or VIP, or attempt to install other port adapters when the system is operating. To install or replace port adapters, first remove the Catalyst RSM/VIP2, Cisco 7304 PCI port adapter carrier card or VIP from the router.

It is wise to gracefully shut down the system before removing a port adapter that has active traffic moving through it. Removing a port adapter while traffic is flowing through the ports can cause system disruption. Once the port adapter is inserted, the ports can be brought back up.



Note

As you disengage the port adapter from the router or switch, online insertion and removal (OIR) administratively shuts down all active interfaces in the port adapter.

OIR allows you to install and replace port adapters while the router is operating; you do not need to notify the software or shut down the system power, although you should not run traffic through the port adapter you are removing while it is being removed. OIR is a method that is seamless to end users on the network, maintains all routing information, and preserves sessions.

The following is a functional description of OIR for background information only; for specific procedures for installing and replacing a port adapter in a supported platform, refer to the [“Port Adapter Removal and Installation”](#) section on page 3-4.

Each port adapter has a bus connector that connects it to the router. The connector has a set of tiered pins in three lengths that send specific signals to the system as they make contact with the port adapter. The system assesses the signals it receives and the order in which it receives them to determine if a port adapter is being removed from or introduced to the system. From these signals, the system determines whether to reinitialize a new interface or to shut down a disconnected interface.

Specifically, when you insert a port adapter, the longest pins make contact with the port adapter first, and the shortest pins make contact last. The system recognizes the signals and the sequence in which it receives them.

When you remove or insert a port adapter, the pins send signals to notify the system of changes. The router then performs the following procedure:

1. Rapidly scans the system for configuration changes.
2. Initializes newly inserted port adapters or administratively shuts down any vacant interfaces.
3. Brings all previously configured interfaces on the port adapter back to their previously installed state. Any newly inserted interface is put in the administratively shutdown state, as if it was present (but not configured) at boot time. If a similar port adapter type is reinserted into a slot, its ports are configured and brought online up to the port count of the originally installed port adapter of that type.

**Note**

Before you begin installation, read [Chapter 2, “Preparing for Installation,”](#) for a list of parts and tools required for installation.

Warnings and Cautions

Observe the following warnings and cautions when installing or removing port adapters.

**Caution**

Do not slide a port adapter all the way into the slot until you have connected all required cables. Trying to do so disrupts normal operation of the router or switch.

**Note**

If a port adapter lever or other retaining mechanism does not move to the locked position, the port adapter is not completely seated in the midplane. Carefully pull the port adapter halfway out of the slot, reinsert it, and move the port adapter lever or other mechanism to the locked position.

**Caution**

To prevent jamming the carrier between the upper and the lower edges of the port adapter slot, and to ensure that the edge connector at the rear of the port adapter mates with the connection at the rear of the port adapter slot, make certain that the carrier is positioned correctly, as shown in the cutaway illustrations in the [“Port Adapter Removal and Installation”](#) section on page 3-4.

**Warning**

When performing the following procedures, wear a grounding wrist strap to avoid ESD damage to the card. Some platforms have an ESD connector for attaching the wrist strap. Do not directly touch the midplane or backplane with your hand or any metal tool, or you could shock yourself.

Port Adapter Removal and Installation

In this section, the illustrations that follow give step-by-step instructions on how to remove and install port adapters. This section contains the following illustrations:

- [Catalyst RSM/VIP2—Removing and Installing a Port Adapter, page 3-5](#)
- [Cisco 7100 Series Routers—Removing and Installing a Port Adapter, page 3-6](#)
- [Cisco 7200 Series Routers and Cisco 7200 VXR Routers—Removing and Installing a Port Adapter, page 3-7](#)
- [Cisco uBR7200 Series Routers—Removing a Port Adapter, page 3-8](#)
- [Cisco uBR7200 Series Routers—Installing a Port Adapter, page 3-9](#)
- [Cisco 7201 Router—Removing and Installing a Port Adapter, page 3-10](#)
- [Cisco 7301 Router—Removing and Installing a Port Adapter, page 3-11](#)
- [Cisco 7304 PCI Port Adapter Carrier Card—Removing and Installing a Port Adapter, page 3-12](#)
- [Cisco 7401ASR Router—Removing and Installing a Port Adapter, page 3-14](#)
- [VIP—Removing and Installing a Port Adapter, page 3-15](#)

Catalyst RSM/VIP2—Removing and Installing a Port Adapter

Note: You must first remove the Catalyst RSM/VIP2 from the chassis before removing a port adapter from the Catalyst RSM/VIP2.

Step 1

To remove the port adapter, remove the screw that secures the port adapter (or blank port adapter). (See A.)

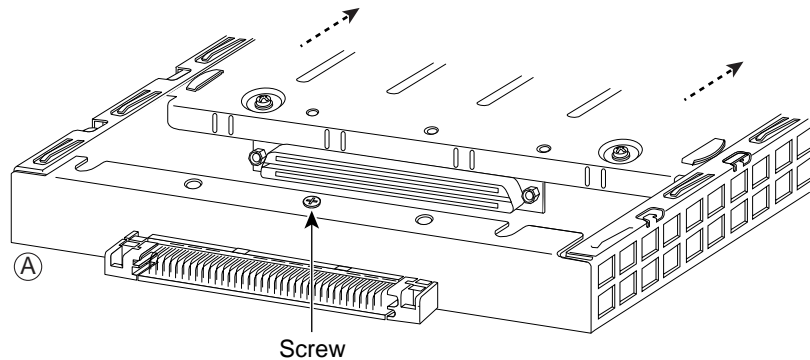

Step 2

With the screw removed, grasp the handle on the front of the port adapter (or blank port adapter) and carefully pull it out of its slot, away from the edge connector at the rear of the slot. (See A.)

Step 3

To install the port adapter, carefully align the port adapter carrier between the upper and the lower edges of the port adapter slot. (See B.)

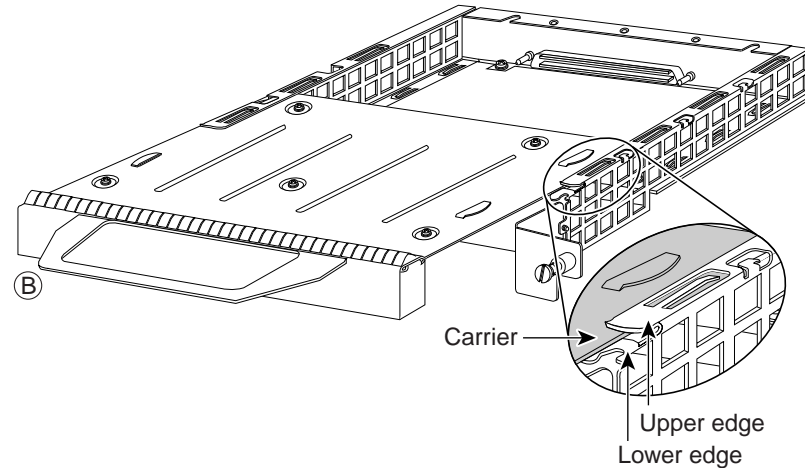

Step 4

Install the screw in the rear of the port adapter slot. Do not overtighten the screw. (See A.)

Step 5

Carefully slide the new port adapter into the port adapter slot until the connector on the port adapter is completely seated in the connector at the rear of the port adapter slot. (See B.)

Step 6

Reinstall the Catalyst RSM/VIP2 motherboard in the chassis and tighten the captive installation screw on each side of the Catalyst RSM/VIP2 faceplate. (See C.)

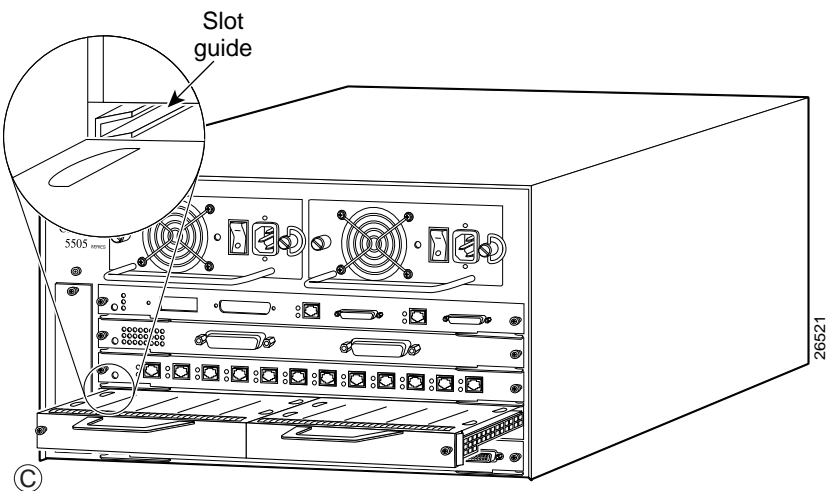

Cisco 7100 Series Routers—Removing and Installing a Port Adapter

Step 1

To remove the port adapter, use a number 2 Phillips screwdriver to loosen the screws on the locking tab. Then slide the tab down to the unlocked position.

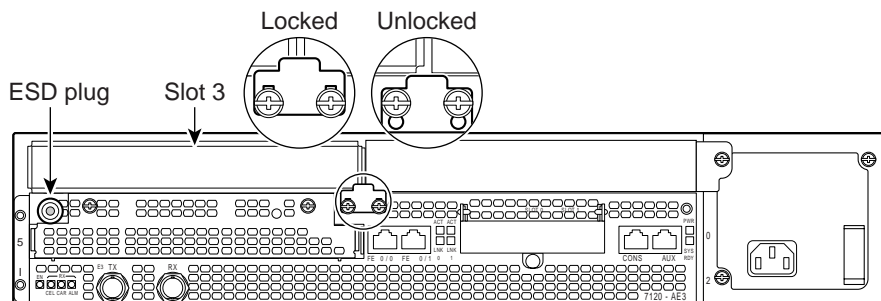

Step 2

Grasp the handle of the port adapter and pull the port adapter from the router, about halfway out of its slot. If you are removing a blank port adapter, pull the blank port adapter completely out of the chassis slot.

Step 3

With the port adapter halfway out of the slot, disconnect all cables from the port adapter.

Step 4

After disconnecting the cables, pull the port adapter from its chassis slot.

Step 5

To insert the port adapter, carefully align the port adapter carrier between the upper and the lower edges of the port adapter slot.

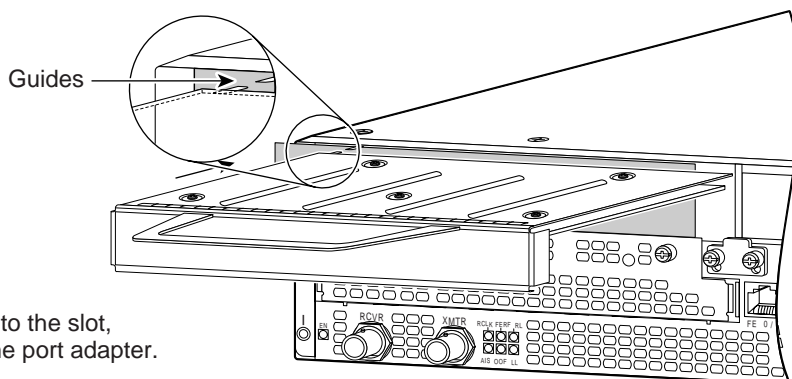

Step 6

With the port adapter halfway into the slot, connect all required cables to the port adapter.

Step 7

After connecting all required cables, carefully slide the port adapter all the way into the slot until the port adapter is seated in the router midplane.

Step 8

After the port adapter is properly seated, lock the port adapter retaining mechanism.

26522

Cisco 7200 Series Routers and Cisco 7200 VXR Routers—Removing and Installing a Port Adapter

Step 1

To remove the port adapter, place the port adapter lever in the unlocked position. (See A.) The port adapter lever remains in the unlocked position.

Step 2

Grasp the handle of the port adapter and pull the port adapter from the router, about halfway out of its slot. If you are removing a blank port adapter, pull the blank port adapter completely out of the chassis slot.

Step 3

With the port adapter halfway out of the slot, disconnect all cables from the port adapter. After disconnecting the cables, pull the port adapter from its chassis slot.

Step 4

To insert the port adapter, carefully align the port adapter carrier between the upper and the lower edges of the port adapter slot. (See B.)

Step 5

Carefully slide the new port adapter halfway into the port adapter slot. (See B.)

Step 6

With the port adapter halfway into the slot, connect all required cables to the port adapter. After connecting all required cables, carefully slide the port adapter all the way into the slot until the port adapter is seated in the router midplane.

Step 7

After the port adapter is properly seated, lock the port adapter lever. (See A.)

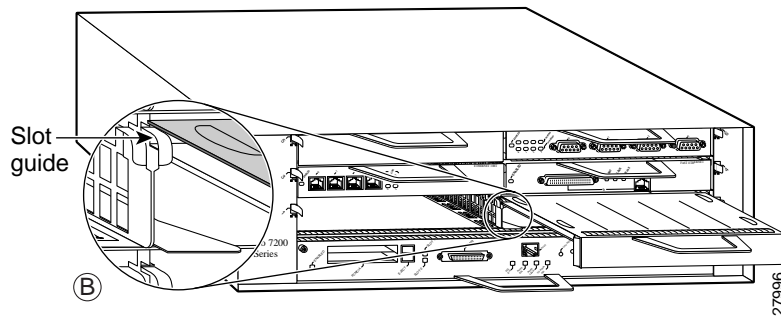
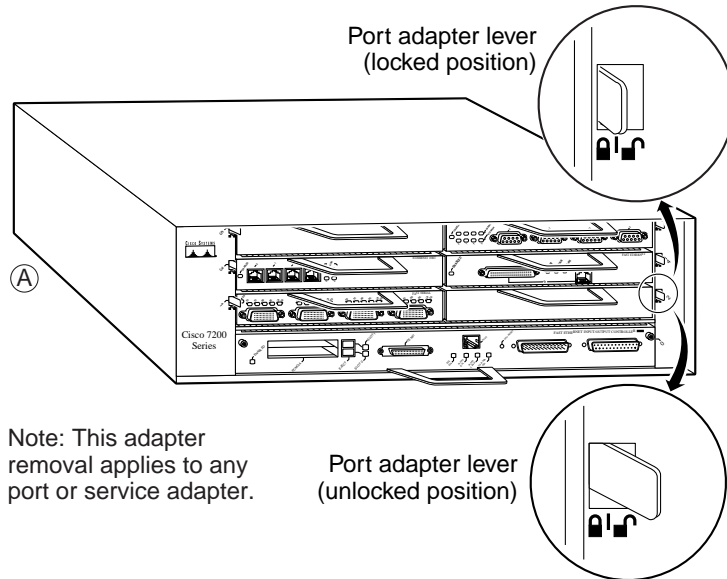

Cisco uBR7200 Series Routers—Removing a Port Adapter

Step 1

To remove the port adapter, unlock the port adapter retaining mechanism. The port adapter lever remains in the unlocked position.

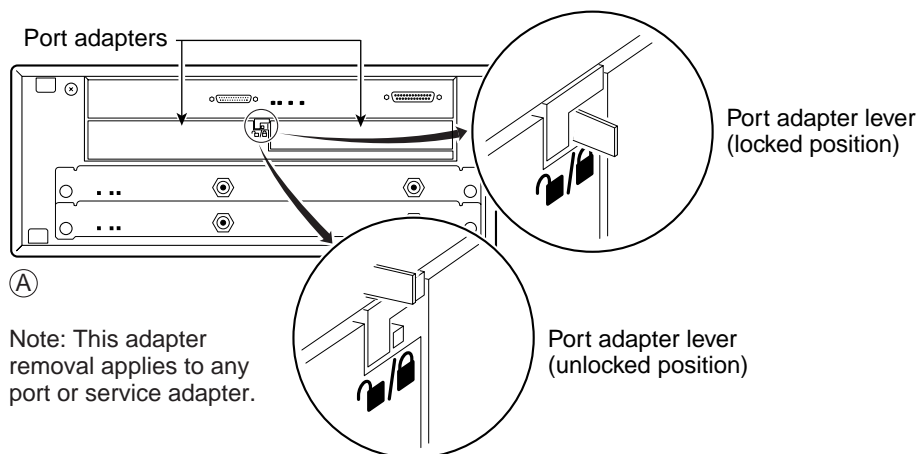

Place the port adapter lever (Cisco uBR7223, see A), or the port adapter retention clip (Cisco uBR7246 and Cisco uBR7246 VXR, see B) in the unlocked position. Either mechanism remains in the unlocked position.

Step 2

Grasp the handle of the port adapter and pull the port adapter from the router, about halfway out of its slot.

If you are removing a blank port adapter, pull the blank port adapter completely out of the chassis slot.

Step 3

With the port adapter halfway out of the slot, disconnect all cables from the port adapter. After disconnecting the cables, pull the port adapter from its chassis slot.

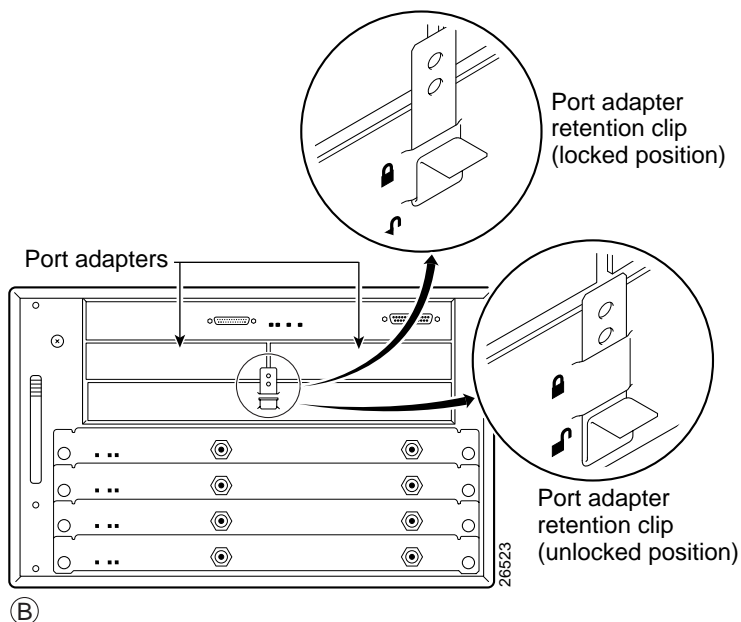

Cisco uBR7200 Series Routers—Installing a Port Adapter

Step 1

To insert the port adapter, carefully align the port adapter carrier between the upper and the lower edges of the port adapter slot.

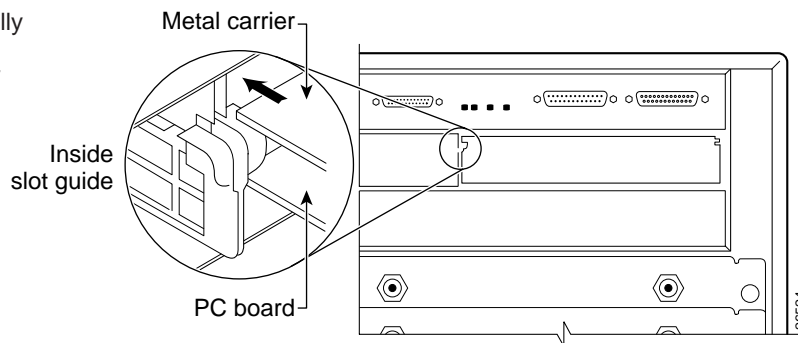

Step 2

Carefully slide the new port adapter halfway into the port adapter slot.

Step 3

With the port adapter halfway into the slot, connect all required cables to the port adapter. After connecting all required cables, carefully slide the port adapter all the way into the slot until the port adapter is seated in the router midplane.

Step 4

After the port adapter is properly seated, lock the port adapter lever or retention clip, depending on your system. (See illustration on preceding page.)

Cisco 7201 Router—Removing and Installing a Port Adapter

Step 1

Use an ESD wrist strap to ground yourself to the router.

Step 2

To remove the port adapter, place the port adapter lever in the unlocked position. The port adapter lever remains in the unlocked position.

Step 3

Grasp the handle of the port adapter and pull the port adapter about halfway out of its slot. If you are removing a blank port adapter, pull the blank port adapter completely out of the chassis slot.

Step 4

With the port adapter halfway out of the slot, disconnect all cables from the port adapter. After disconnecting the cables, pull the port adapter from the chassis slot.

Caution

The port adapter must slide into the slot guides close to the chassis lid. Do not allow the port adapter components to come in contact with the system board or the port adapter could be damaged.

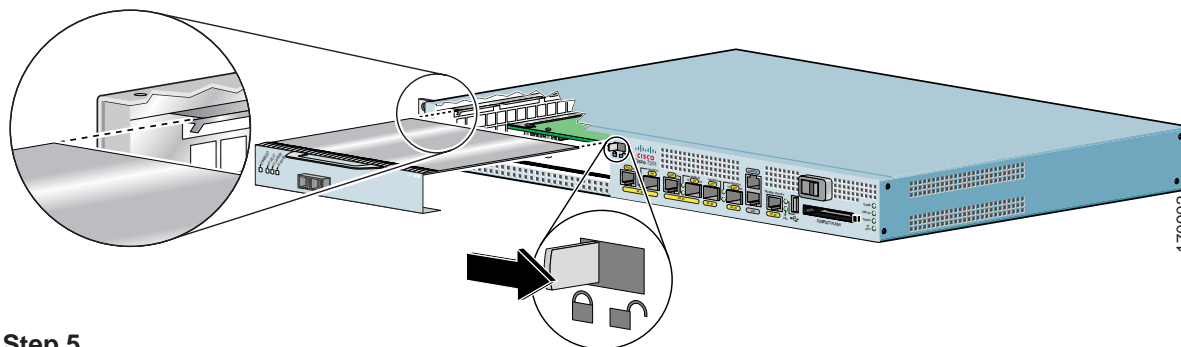

Step 5

To insert the port adapter, carefully align the port adapter carrier in the slot guides. Slide the new port adapter halfway into the chassis.

Step 6

Connect all the required cables to the port adapter. After connecting all required cables, carefully slide the port adapter all the way into the slot until the port adapter is seated in the midplane.

Step 7

After the port adapter is properly seated, lock the port adapter lever.

Cisco 7301 Router—Removing and Installing a Port Adapter

Step 1

Use an ESD wrist strap to ground yourself to the router.

Step 2

To remove a port adapter, use a Phillips screwdriver to turn the screw holding the port adapter latch. The screw should be loose enough to allow the latch to rotate to an unlocked position. (See A.) The latch can rotate 360°.

Step 3

Grasp the handle and pull the port adapter from the router, about halfway out of its slot. (See B.) If you are removing a blank port adapter, pull the blank port adapter completely out of the chassis slot.

Step 4

With the port adapter halfway out of the slot, disconnect all cables from the port adapter. After disconnecting the cables, pull the port adapter from its chassis slot.

Caution

The port adapter must slide into the slot guides close to the chassis lid. (See C.) Do not allow the port adapter components to come in contact with the system board or the port adapter could be damaged.

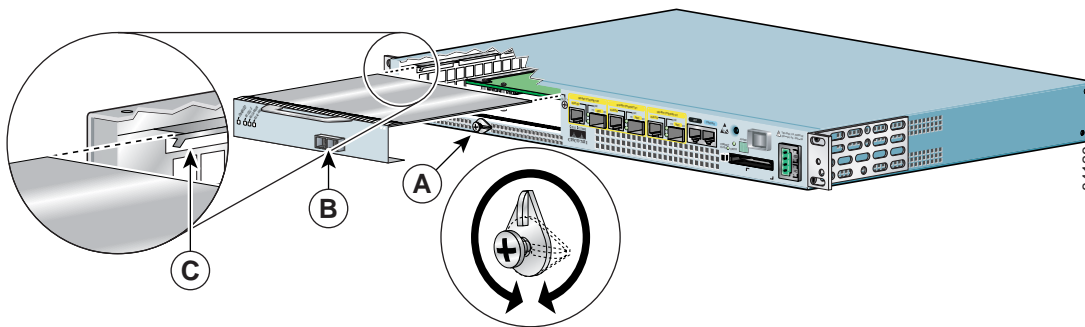

Step 5

To insert the port adapter, carefully align the port adapter carrier in the slot guides. (See C.) Slide the new port adapter halfway into the chassis.

Step 6

Connect all required cables to the port adapter. After connecting all required cables, carefully slide the port adapter all the way into the slot until the port adapter is seated in the midplane.

Step 7

After the port adapter is properly seated, turn and secure the port adapter latch in the upright, locked position. (See A.) Tighten the screw to ensure the port adapter remains firmly in place.

Cisco 7304 PCI Port Adapter Carrier Card—Removing and Installing a Port Adapter

You can install one single-width port adapter in a Cisco 7304 PCI Port Adapter Carrier Card. This section provides step-by-step instructions for removing and installing a port adapter in a Cisco 7304 PCI Port Adapter Carrier Card.



Warning

When performing the following procedures, wear a grounding wrist strap to avoid ESD damage to the Cisco 7304 PCI Port Adapter Carrier Card. Some platforms have an ESD connector for attaching the wrist strap. Do not directly touch the midplane or backplane with your hand or any metal tool, or you could shock yourself.

To remove and install a port adapter in a Cisco 7304 PCI Port Adapter Carrier Card, refer to [Figure 3-2](#) and do the following:

- Step 1** If the Cisco 7304 PCI Port Adapter Carrier Card is still in the router, you must remove the Cisco 7304 PCI Port Adapter Carrier Card before removing a port adapter.
- Step 2** To remove the port adapter from the Cisco 7304 PCI Port Adapter Carrier Card, turn the port adapter lock from its locked and horizontal position shown in A of [Figure 3-2](#) to its unlocked and vertical position shown in B of [Figure 3-2](#).
- Step 3** Grasp the handle of the port adapter and pull the port adapter from the Cisco 7304 PCI Port Adapter Carrier Card. (You have already disconnected the cables from the port adapter when removing the Cisco 7304 PCI Port Adapter Carrier Card).
- Step 4** To insert the port adapter in the Cisco 7304 PCI Port Adapter Carrier Card, locate the guide rails inside the Cisco 7304 PCI Port Adapter Carrier Card that hold the port adapter in place. They are at the top left and top right of the port adapter slot and are recessed about an inch, as shown in C of [Figure 3-2](#).
- Step 5** Carefully slide the port adapter in the Cisco 7304 PCI Port Adapter Carrier Card until the port adapter makes contact with the port adapter interface connector. When fully seated, the port adapter front panel should be flush with the face of the Cisco 7304 PCI Port Adapter Carrier Card.
- Step 6** After the port adapter is properly seated, turn the port adapter lock to its locked and horizontal position, as shown in A of [Figure 3-2](#).

Cisco 7401ASR Router—Removing and Installing a Port Adapter

Step 1

To remove the port adapter, use a number 2 Phillips screwdriver to loosen the screw on the port adapter latch. Rotate the port adapter latch until it clears the faceplate of the port adapter. (See A.) The latch can rotate 360°.

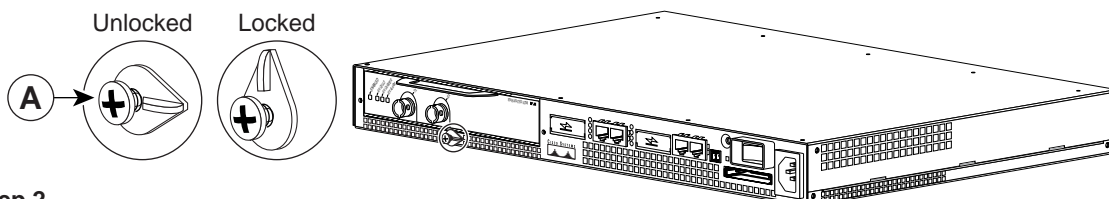

Step 2

Pull the port adapter from the router, about halfway out of its slot. (If you remove a blank port adapter, keep the blank port adapter for use in the router if you should ever remove the port adapter. The port adapter slot must always be filled.)

Step 3

With the port adapter halfway out of the slot, disconnect all cables from the port adapter. After disconnecting the cables, pull the port adapter completely out of the chassis slot.

Step 4

To insert the port adapter, locate the port adapter slot guides inside the Cisco 7401ASR router. They are near the top, and are recessed about 1/2 inch. (See B.)

Caution

The port adapter must slide into the slot guides under the chassis lid. Do not allow the port adapter components to come in contact with the system board, or the port adapter could be damaged.

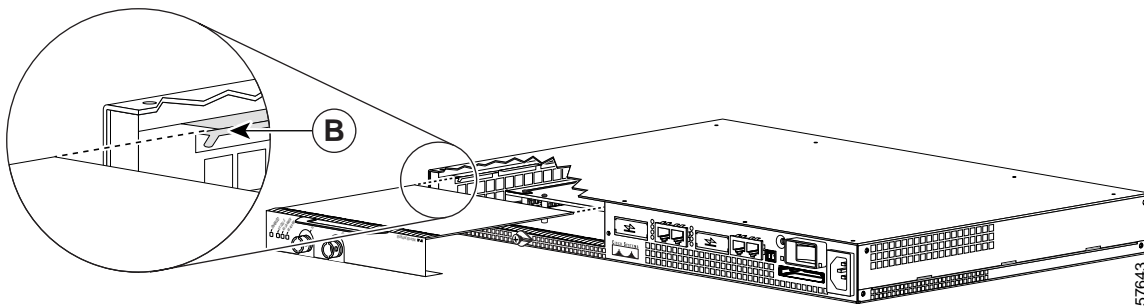

Step 5

Insert the port adapter in the slot guides halfway, and then reconnect the port adapter cables.

Step 6

After the cables are connected, carefully slide the port adapter all the way into the slot until the port adapter is seated in the router midplane. When installed, the port adapter input/output panel should be flush with the face of the router.

Step 7

After the port adapter is properly seated, rotate the port adapter latch to the upright locked position and use a number 2 Phillips screwdriver to tighten the latch screw. If needed, loosen the latch screw to rotate the latch over the port adapter. Finish the installation by tightening the latch screw.

VIP—Removing and Installing a Port Adapter

Note: You must first remove the VIP from the chassis before removing a port adapter from the VIP.

Step 1

To remove the port adapter, remove the screw that secures the port adapter (or blank port adapter). (See A.)

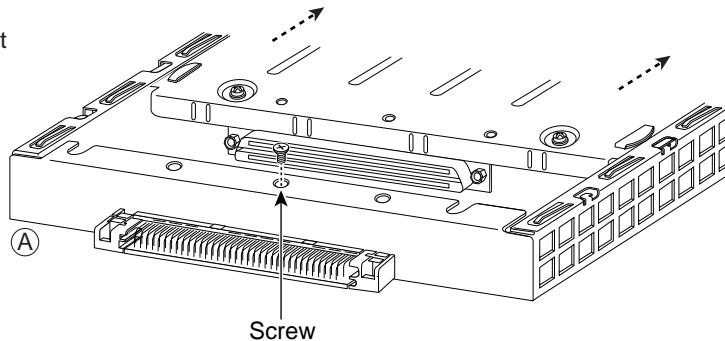

Step 2

With the screw removed, grasp the handle on the front of the port adapter (or blank port adapter) and carefully pull it out of its slot, away from the edge connector at the rear of the slot. (See A.)

Step 3

To insert the port adapter, carefully align the port adapter carrier between the upper and the lower edges of the port adapter slot. (See B.)

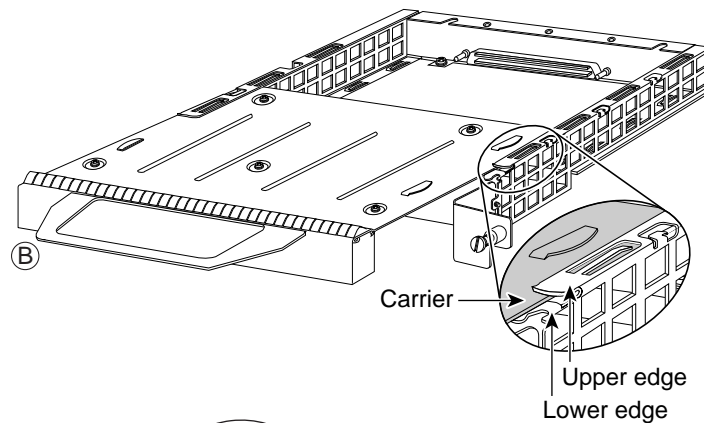

Step 4

Carefully slide the new port adapter into the port adapter slot until the connector on the port adapter is completely seated in the connector at the rear of the port adapter slot. (See B.)

Step 5

Install the screw in the rear of the port adapter slot on the VIP. Do not overtighten the screw. (See A.)

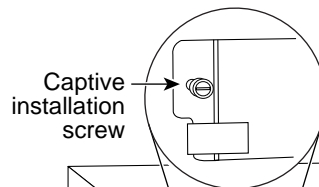

Step 6

Carefully slide the VIP motherboard into the interface processor slot until the connectors at the rear of the VIP are completely seated in the connectors at the rear of the interface processor slot. Use the ejector levers to seat the VIP in the interface processor slot. Tighten the captive installation screws on the VIP. (See C.)

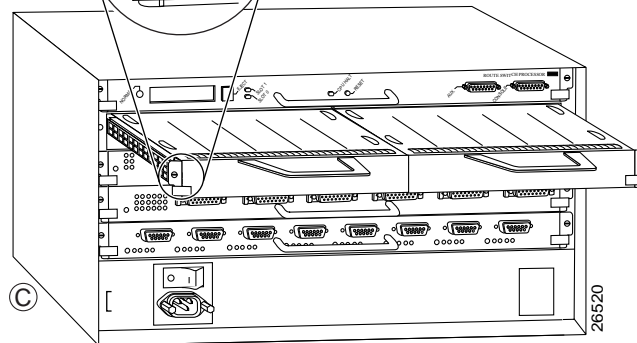

Connecting PA-8E Interface Cables

On a single PA-8E, you can use up to eight RJ-45 connectors.

Note

RJ-45 cables are not available from Cisco Systems; they are available from outside commercial cable vendors.

Connect RJ-45 cables to the PA-8E port adapter as follows:

- Step 1** Attach the Category 5 unshielded twisted-pair (UTP) cable directly to the RJ-45 port on the PA-8E. (See [Figure 3-3](#).)

Note

The PA-8E is an end station device and not a repeater. You *must* connect the PA-8E to a repeater or hub.

Figure 3-3 Connecting PA-8E RJ-45 Cables

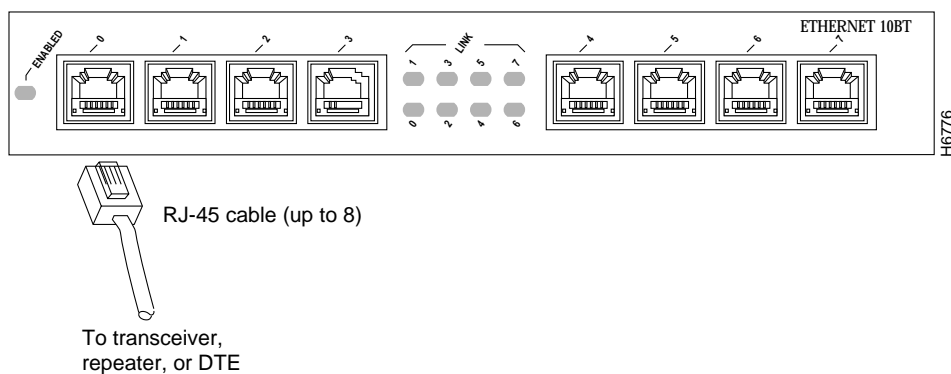
Note

Port adapters have a handle attached, but this handle is not shown in [Figure 3-3](#) to allow a full view of the detail on each port adapter's faceplate.

- Step 2** Attach the network end of your RJ-45 cable to your 10BaseT hub or repeater, data terminal equipment (DTE), or other external 10BaseT equipment.
- Step 3** Repeat [Step 1](#) and [Step 2](#) for each of the remaining 10BaseT interfaces you want to install. This completes the PA-8E installation.



CHAPTER 4

Configuring the PA-8E

To continue your PA-8E port adapter installation, you must configure the ethernet interfaces. The instructions that follow apply to all supported platforms. Minor differences between the platforms are noted.

This chapter contains the following sections:

- [Using the EXEC Command Interpreter, page 4-1](#)
- [Configuring the PA-8E Interfaces, page 4-2](#)
- [Checking the Configuration, page 4-10](#)

Using the EXEC Command Interpreter

You modify the configuration of your router through the software command interpreter called the EXEC (also called enable mode). You must enter the privileged level of the EXEC command interpreter with the **enable** command before you can use the **configure** command to configure a new interface or to change the existing configuration of an interface. The system prompts you for a password if one has been set. The system prompt for the privileged level ends with a pound sign (#) instead of an angle bracket (>).

At the console terminal, use the following procedure to enter the privileged level:

-
- Step 1** At the user-level EXEC prompt, enter the **enable** command. The EXEC prompts you for a privileged-level password as follows:

```
Router> enable
```

```
Password:
```

- Step 2** Enter the password (the password is case sensitive). For security purposes, the password is not displayed. When you enter the correct password, the system displays the privileged-level system prompt (#):

```
Router#
```

Configuring the PA-8E Interfaces

After you verify that the new PA-8E is installed correctly (the enabled LED goes on), use the privileged-level **configure** command to configure the new interfaces. Have the following information available:

- Protocols you plan to route on each new interface
- IP addresses, if you plan to configure the interfaces for IP routing
- Bridging protocols you plan to use

If you installed a new PA-8E or if you want to change the configuration of an existing interface, you must enter configuration mode to configure the new interfaces. If you replaced a PA-8E that was previously configured, the system recognizes the new interfaces and brings each of them up in their existing configurations.



Note

The PA-8E interfaces can both be configured at 10 Mbps, full duplex (FDX), for a maximum aggregate bandwidth of 80 Mbps.

For a summary of the configuration options available and instructions for configuring interfaces on a PA-8E, refer to the appropriate configuration publications listed in the [“Related Documentation” section on page viii](#).

You execute configuration commands from the privileged level of the EXEC command interpreter, which usually requires password access. Contact your system administrator, if necessary, to obtain password access. (See the [“Using the EXEC Command Interpreter” section on page 4-1](#) for an explanation of the privileged level of the EXEC.)

This section contains the following subsections:

- [Shutting Down an Interface, page 4-2](#)
- [Performing a Basic Interface Configuration, page 4-8](#)

Shutting Down an Interface

Before you remove an interface that you will not replace, or replace port adapters, use the **shutdown** command to shut down (disable) the interfaces to prevent anomalies when you reinstall the new or reconfigured port adapter. When you shut down an interface, it is designated *administratively down* in the **show** command displays.

Follow these steps to shut down an interface:

-
- Step 1** Enter the privileged level of the EXEC command interpreter (also called enable mode). (See the [“Using the EXEC Command Interpreter” section on page 4-1](#) for instructions.)
- Step 2** At the privileged-level prompt, enter configuration mode and specify that the console terminal is the source of the configuration subcommands, as follows:
- ```
Router# configure terminal
Enter configuration commands, one per line. End with CNTL/Z.
Router(config)#
```
- Step 3** Shut down interfaces by entering the **interface ethernet** subcommand (followed by the interface address of the interface), and then enter the **shutdown** command.

When you have finished, press **Ctrl-Z**—hold down the **Control** key while you press **Z**—or enter **end** or **exit** to exit configuration mode and return to the EXEC command interpreter.

Table 4-1 shows the **shutdown** command syntax for the supported platforms.

**Table 4-1** Syntax of the **shutdown** Command for the Supported Platforms

| Platform                                             | Command                                                                                                                                                         | Example                                                                                                                                                                                                                                                                                                      |
|------------------------------------------------------|-----------------------------------------------------------------------------------------------------------------------------------------------------------------|--------------------------------------------------------------------------------------------------------------------------------------------------------------------------------------------------------------------------------------------------------------------------------------------------------------|
| Catalyst RSM/VIP2 in Catalyst 5000 family switches   | <b>interface</b> , followed by the <i>type</i> ( <b>ethernet</b> ) and <i>slot/port</i> (port-adapter-slot-number/interface-port-number)<br><br><b>shutdown</b> | The example is for interface 0 and interface 1 on a port adapter in port adapter slot 1.<br><br>Router(config-if)# <b>interface ethernet 1/0</b><br>Router(config-if)# <b>shutdown</b><br>Router(config-if)# <b>interface ethernet 1/1</b><br>Router(config-if)# <b>shutdown</b><br><b>Ctrl-Z</b><br>Router# |
| Cisco 7120 series routers                            | <b>interface</b> , followed by the <i>type</i> ( <b>ethernet</b> ) and <i>slot/port</i> (port-adapter-slot-number/interface-port-number)<br><br><b>shutdown</b> | The example is for interface 0 and interface 1 on a port adapter in port adapter slot 3.<br><br>Router(config-if)# <b>interface ethernet 3/0</b><br>Router(config-if)# <b>shutdown</b><br>Router(config-if)# <b>interface ethernet 3/1</b><br>Router(config-if)# <b>shutdown</b><br><b>Ctrl-Z</b><br>Router# |
| Cisco 7140 series routers                            | <b>interface</b> , followed by the <i>type</i> ( <b>ethernet</b> ) and <i>slot/port</i> (port-adapter-slot-number/interface-port-number)<br><br><b>shutdown</b> | The example is for interface 0 and interface 1 on a port adapter in port adapter slot 4.<br><br>Router(config-if)# <b>interface ethernet 4/0</b><br>Router(config-if)# <b>shutdown</b><br>Router(config-if)# <b>interface ethernet 4/1</b><br>Router(config-if)# <b>shutdown</b><br><b>Ctrl-Z</b><br>Router# |
| Cisco 7200 series routers and Cisco 7200 VXR routers | <b>interface</b> , followed by the <i>type</i> ( <b>ethernet</b> ) and <i>slot/port</i> (port-adapter-slot-number/interface-port-number)<br><br><b>shutdown</b> | The example is for interface 0 and interface 1 on a port adapter in port adapter slot 6.<br><br>Router(config-if)# <b>interface ethernet 6/0</b><br>Router(config-if)# <b>shutdown</b><br>Router(config-if)# <b>interface ethernet 6/1</b><br>Router(config-if)# <b>shutdown</b><br><b>Ctrl-Z</b><br>Router# |
| Cisco 7201 router                                    | <b>interface</b> , followed by the <i>type</i> ( <b>ethernet</b> ) and <i>slot/port</i> (port-adapter-slot-number/interface-port-number)<br><br><b>shutdown</b> | The example is for interface 0 and interface 1 on a port adapter in port adapter slot 1.<br><br>Router(config-if)# <b>interface ethernet 1/0</b><br>Router(config-if)# <b>shutdown</b><br>Router(config-if)# <b>interface ethernet 1/1</b><br>Router(config-if)# <b>shutdown</b><br><b>Ctrl-Z</b><br>Router# |

Table 4-1 Syntax of the shutdown Command for the Supported Platforms (continued)

| Platform                                                        | Command                                                                                                                                                                                             | Example                                                                                                                                                                                                                                                                                                                                                                     |
|-----------------------------------------------------------------|-----------------------------------------------------------------------------------------------------------------------------------------------------------------------------------------------------|-----------------------------------------------------------------------------------------------------------------------------------------------------------------------------------------------------------------------------------------------------------------------------------------------------------------------------------------------------------------------------|
| Cisco uBR7223 router                                            | <b>interface</b> , followed by the <i>type (ethernet)</i> and <i>slot/port</i> (port-adapter-slot-number/interface-port-number)<br><br><b>shutdown</b>                                              | The example is for interface 0 and interface 1 on a port adapter in port adapter slot 1.<br><br>Router(config-if)# <b>interface ethernet 1/0</b><br>Router(config-if)# <b>shutdown</b><br>Router(config-if)# <b>interface ethernet 1/1</b><br>Router(config-if)# <b>shutdown</b><br><b>Ctrl-Z</b><br>Router#                                                                |
| Cisco uBR7246 router                                            | <b>interface</b> , followed by the <i>type (ethernet)</i> and <i>slot/port</i> (port-adapter-slot-number/interface-port-number)<br><br><b>shutdown</b>                                              | The example is for interface 0 and interface 1 on a port adapter in port adapter slot 2.<br><br>Router(config-if)# <b>interface ethernet 2/0</b><br>Router(config-if)# <b>shutdown</b><br>Router(config-if)# <b>interface ethernet 2/1</b><br>Router(config-if)# <b>shutdown</b><br><b>Ctrl-Z</b><br>Router#                                                                |
| Cisco 7301 router                                               | <b>interface</b> , followed by the <i>type (ethernet)</i> and <i>slot/port</i> (port-adapter-slot-number/interface-port-number)<br><br><b>shutdown</b>                                              | The example is for interface 0 and interface 1 on a port adapter in port adapter slot 1.<br><br>Router(config-if)# <b>interface ethernet 1/0</b><br>Router(config-if)# <b>shutdown</b><br>Router(config-if)# <b>interface ethernet 1/1</b><br>Router(config-if)# <b>shutdown</b><br><b>Ctrl-Z</b><br>Router#                                                                |
| Cisco 7304 PCI Port Adapter Carrier Card in a Cisco 7304 router | <b>interface</b> , followed by the <i>type (ethernet)</i> <i>slot/port</i> (module-slot-number/interface-port-number)<br><br><b>shutdown</b>                                                        | The example is for interface 0 and interface 1 on a port adapter in a Cisco 7304 PCI Port Adapter Carrier Card in module slot 3 of a Cisco 7304 router.<br><br>Router(config-if)# <b>interface ethernet 3/0</b><br>Router(config-if)# <b>shutdown</b><br>Router(config-if)# <b>interface ethernet 3/1</b><br>Router(config-if)# <b>shutdown</b><br><b>Ctrl-Z</b><br>Router# |
| Cisco 7401ASR router                                            | <b>interface</b> , followed by the <i>type (ethernet)</i> and <i>slot/port</i> (port-adapter-slot-number/interface-port-number)<br><br><b>shutdown</b>                                              | The example is for interface 0 and interface 1 on a port adapter in port adapter slot 1.<br><br>Router(config-if)# <b>interface ethernet 1/0</b><br>Router(config-if)# <b>shutdown</b><br>Router(config-if)# <b>interface ethernet 1/1</b><br>Router(config-if)# <b>shutdown</b><br><b>Ctrl-Z</b><br>Router#                                                                |
| VIP in Cisco 7000 series routers or Cisco 7500 series routers   | <b>interface</b> , followed by the <i>type (ethernet)</i> and <i>slot/port adapter/port</i> (interface-processor-slot-number/port-adapter-slot-number/interface-port-number)<br><br><b>shutdown</b> | The example is for interface 1 and interface 0 on a port adapter in port adapter slot 1 of a VIP installed in interface processor slot 1.<br><br>Router(config-if)# <b>interface ethernet 1/1/1</b><br>Router(config-if)# <b>shutdown</b><br>Router(config-if)# <b>interface ethernet 1/1/0</b><br>Router(config-if)# <b>shutdown</b><br><b>Ctrl-Z</b><br>Router#           |



**Note** If you need to shut down additional interfaces, enter the **interface ethernet** command (followed by the interface address of the interface) for each of the interfaces on your port adapter. Use the **no shutdown** command to enable the interface.

**Step 4** Write the new configuration to NVRAM as follows:

```
Router# copy running-config startup-config
[OK]
Router#
```

The system displays an OK message when the configuration has been stored in NVRAM.

**Step 5** Verify that new interfaces are now in the correct state (shut down) using the **show interfaces** command (followed by the interface type and interface address of the interface) to display the specific interface.

[Table 4-2](#) provides examples of the **show interfaces ethernet** command for the supported platforms.

**Table 4-2** Examples of the *show interfaces ethernet* Command for the Supported Platforms

| Platform                                           | Command                                                                                                         | Example                                                                                                                                                                                                                                                       |
|----------------------------------------------------|-----------------------------------------------------------------------------------------------------------------|---------------------------------------------------------------------------------------------------------------------------------------------------------------------------------------------------------------------------------------------------------------|
| Catalyst RSM/VIP2 in Catalyst 5000 family switches | <b>show interfaces ethernet</b> , followed by <i>slot/port</i> (port-adapter-slot-number/interface-port-number) | The example is for interface 0 on a port adapter in port adapter slot 1.<br><br>Router# <b>show interfaces ethernet 1/0</b><br><br>ethernet 1/0 is administratively down,<br>line protocol is down<br><br>[Additional display text omitted from this example] |
| Cisco 7120 series routers                          | <b>show interfaces ethernet</b> , followed by <i>slot/port</i> (port-adapter-slot-number/interface-port-number) | The example is for interface 0 on a port adapter in port adapter slot 3.<br><br>Router# <b>show interfaces ethernet 3/0</b><br><br>ethernet 3/0 is administratively down,<br>line protocol is down<br><br>[Additional display text omitted from this example] |
| Cisco 7140 series routers                          | <b>show interfaces ethernet</b> , followed by <i>slot/port</i> (port-adapter-slot-number/interface-port-number) | The example is for interface 0 on a port adapter in port adapter slot 4.<br><br>Router# <b>show interfaces ethernet 4/0</b><br><br>ethernet 4/0 is administratively down,<br>line protocol is down<br><br>[Additional display text omitted from this example] |

Table 4-2 Examples of the `show interfaces ethernet` Command for the Supported Platforms (continued)

| Platform                                             | Command                                                                                                         | Example                                                                                                                                                                                                                                                |
|------------------------------------------------------|-----------------------------------------------------------------------------------------------------------------|--------------------------------------------------------------------------------------------------------------------------------------------------------------------------------------------------------------------------------------------------------|
| Cisco 7200 series routers and Cisco 7200 VXR routers | <b>show interfaces ethernet</b> , followed by <i>slot/port</i> (port-adapter-slot-number/interface-port-number) | The example is for interface 0 on a port adapter in port adapter slot 6.<br>Router# <b>show interfaces ethernet 6/0</b><br><br>ethernet 6/0 is administratively down, line protocol is down<br><br>[Additional display text omitted from this example] |
| Cisco 7201 router                                    | <b>show interfaces ethernet</b> , followed by <i>slot/port</i> (port-adapter-slot-number/interface-port-number) | The example is for interface 0 on a port adapter in port adapter slot 1.<br>Router# <b>show interfaces ethernet 1/0</b><br><br>ethernet 1/0 is administratively down, line protocol is down<br><br>[Additional display text omitted from this example] |
| Cisco uBR7223 router                                 | <b>show interfaces ethernet</b> , followed by <i>slot/port</i> (port-adapter-slot-number/interface-port-number) | The example is for interface 0 on a port adapter in port adapter slot 1.<br>Router# <b>show interfaces ethernet 1/0</b><br><br>ethernet 1/0 is administratively down, line protocol is down<br><br>[Additional display text omitted from this example] |
| Cisco uBR7246 router                                 | <b>show interfaces ethernet</b> , followed by <i>slot/port</i> (port-adapter-slot-number/interface-port-number) | The example is for interface 0 on a port adapter in port adapter slot 2.<br>Router# <b>show interfaces ethernet 2/0</b><br><br>ethernet 2/0 is administratively down, line protocol is down<br><br>[Additional display text omitted from this example] |
| Cisco 7301 router                                    | <b>show interfaces ethernet</b> , followed by <i>slot/port</i> (port-adapter-slot-number/interface-port-number) | The example is for interface 0 on a port adapter in port adapter slot 1.<br>Router# <b>show interfaces ethernet 1/0</b><br><br>ethernet 1/0 is administratively down, line protocol is down<br><br>[Additional display text omitted from this example] |

Table 4-2 Examples of the `show interfaces ethernet` Command for the Supported Platforms (continued)

| Platform                                                        | Command                                                                                                                                                      | Example                                                                                                                                                                                                                                                                                                                   |
|-----------------------------------------------------------------|--------------------------------------------------------------------------------------------------------------------------------------------------------------|---------------------------------------------------------------------------------------------------------------------------------------------------------------------------------------------------------------------------------------------------------------------------------------------------------------------------|
| Cisco 7304 PCI Port Adapter Carrier Card in a Cisco 7304 router | <b>show interfaces ethernet</b> , followed by <i>slot/port</i> (module-slot-number/interface-port-number)                                                    | The example is for interface 0 on a port adapter in a Cisco 7304 PCI Port Adapter Carrier Card in module slot 3 of a Cisco 7304 router.<br><br>Router# <b>show interfaces ethernet 3/0</b><br><br>Ethernet 3/0 is administratively down, line protocol is down<br><br>[Additional display text omitted from this example] |
| Cisco 7401ASR router                                            | <b>show interfaces ethernet</b> , followed by <i>slot/port</i> (port-adapter-slot-number/interface-port-number)                                              | The example is for interface 0 on a port adapter in port adapter slot 1.<br><br>Router# <b>show interfaces ethernet 1/0</b><br><br>ethernet 1/0 is administratively down, line protocol is down<br><br>[Additional display text omitted from this example]                                                                |
| VIP in Cisco 7000 series routers or Cisco 7500 series routers   | <b>show interfaces ethernet</b> , followed by <i>slot/port adapter/port</i> (interface-processor-slot-number/port-adapter-slot-number/interface-port-number) | The example is for interface 0 on a port adapter in port adapter slot 1 of a VIP in interface processor slot 1.<br><br>Router# <b>show interfaces ethernet 1/1/0</b><br><br>ethernet 1/1/0 is administratively down, line protocol is down<br><br>[Additional display text omitted from this example]                     |

- Step 6** Re-enable interfaces by doing the following:
- a. Repeat Step 3 to re-enable an interface. Substitute the **no shutdown** command for the **shutdown** command.
  - b. Repeat Step 4 to write the new configuration to memory. Use the **copy running-config startup-config** command.
  - c. Repeat Step 5 to verify that the interfaces are in the correct state. Use the **show interfaces** command followed by the interface type and interface address of the interface.

For complete descriptions of software configuration commands, refer to the publications listed in the “[Related Documentation](#)” section on page viii.

## Performing a Basic Interface Configuration

Following are instructions for a basic configuration, which include enabling an interface, and specifying IP routing. You might also need to enter other configuration subcommands, depending on the requirements for your system configuration and the protocols you plan to route on the interface. For complete descriptions of configuration subcommands and the configuration options available for ethernet interfaces, refer to the appropriate software documentation.

In the following procedure, press the **Return** key after each step unless otherwise noted. At any time you can exit the privileged level and return to the user level by entering **disable** at the prompt as follows:

```
Router# disable
```

```
Router>
```

- Step 1** Enter configuration mode and specify that the console terminal is the source of the configuration subcommands, as follows:

```
Router# configure terminal
Enter configuration commands, one per line. End with CNTL/Z.
Router(config)#
```

- Step 2** Specify the first interface to configure by entering the **interface ethernet** subcommand, followed by the interface address of the interface you plan to configure. (The command for your port adapter may be different, for example, **interface atm**.)

[Table 4-3](#) provides examples of **interface ethernet** subcommand for the supported platforms.

**Table 4-3** Examples of the interface ethernet Subcommand for the Supported Platforms

| Platform                                             | Command                                                                                                          | Example                                                                                                                                             |
|------------------------------------------------------|------------------------------------------------------------------------------------------------------------------|-----------------------------------------------------------------------------------------------------------------------------------------------------|
| Catalyst RSM/VIP2 in Catalyst 5000 family switches   | <b>interface ethernet</b> , followed by <i>slot/port</i><br>(port-adapter-slot-number/<br>interface-port-number) | The example is for interface 0 of a port adapter in port adapter slot 0.<br><br>Router(config)# <b>interface ethernet 0/0</b><br>Router(config-if)# |
| Cisco 7120 series routers                            | <b>interface ethernet</b> , followed by <i>slot/port</i><br>(port-adapter-slot-number/<br>interface-port-number) | The example is for interface 0 of a port adapter in port adapter slot 3.<br><br>Router(config)# <b>interface ethernet 3/0</b><br>Router(config-if)# |
| Cisco 7140 series routers                            | <b>interface ethernet</b> , followed by <i>slot/port</i><br>(port-adapter-slot-number/<br>interface-port-number) | The example is for interface 0 of a port adapter in port adapter slot 4.<br><br>Router(config)# <b>interface ethernet 4/0</b><br>Router(config-if)# |
| Cisco 7200 series routers and Cisco 7200 VXR routers | <b>interface ethernet</b> , followed by <i>slot/port</i><br>(port-adapter-slot-number/<br>interface-port-number) | The example is for interface 0 of a port adapter in port adapter slot 6.<br><br>Router(config)# <b>interface ethernet 6/0</b><br>Router(config-if)# |
| Cisco 7201 router                                    | <b>interface ethernet</b> , followed by <i>slot/port</i><br>(port-adapter-slot-number/<br>interface-port-number) | The example is for interface 0 of a port adapter in port adapter slot 1.<br><br>Router(config)# <b>interface ethernet 1/0</b><br>Router(config-if)# |

Table 4-3 Examples of the interface ethernet Subcommand for the Supported Platforms (continued)

| Platform                                                        | Command                                                                                                                                                           | Example                                                                                                                                                                                                            |
|-----------------------------------------------------------------|-------------------------------------------------------------------------------------------------------------------------------------------------------------------|--------------------------------------------------------------------------------------------------------------------------------------------------------------------------------------------------------------------|
| Cisco uBR7223 router                                            | <b>interface ethernet</b> , followed by <i>slot/port</i><br>(port-adapter-slot-number/<br>interface-port-number)                                                  | The example is for interface 0 of a port adapter in port adapter slot 1.<br><br>Router(config)# <b>interface ethernet 1/0</b><br>Router(config-if)#                                                                |
| Cisco uBR7246 router                                            | <b>interface ethernet</b> , followed by <i>slot/port</i><br>(port-adapter-slot-number/<br>interface-port-number)                                                  | The example is for interface 0 of a port adapter in port adapter slot 2.<br><br>Router(config)# <b>interface ethernet 2/0</b><br>Router(config-if)#                                                                |
| Cisco 7301 router                                               | <b>interface ethernet</b> , followed by <i>slot/port</i><br>(port-adapter-slot-number/<br>interface-port-number)                                                  | The example is for interface 0 of a port adapter in port adapter slot 1.<br><br>Router(config)# <b>interface ethernet 1/0</b><br>Router(config-if)#                                                                |
| Cisco 7304 PCI Port Adapter Carrier Card in a Cisco 7304 router | <b>interface ethernet</b> , followed by <i>slot/port</i> (module-slot-number/<br>interface-port-number)                                                           | The example is for interface 0 on a port adapter in a Cisco 7304 PCI Port Adapter Carrier Card in module slot 3 of a Cisco 7304 router.<br><br>Router(config)# <b>interface ethernet 3/0</b><br>Router(config-if)# |
| Cisco 7401ASR router                                            | <b>interface ethernet</b> , followed by <i>slot/port</i><br>(port-adapter-slot-number/<br>interface-port-number)                                                  | The example is for interface 0 of a port adapter in port adapter slot 1.<br><br>Router(config)# <b>interface ethernet 1/0</b><br>Router(config-if)#                                                                |
| VIP in Cisco 7000 series routers or Cisco 7500 series routers   | <b>interface ethernet</b> , followed by <i>slot/port adapter/port</i><br>(interface-processor-slot-number/<br>port-adapter-slot-number/<br>interface-port-number) | The example is for interface 0 of a port adapter in port adapter slot 1 of a VIP in interface processor slot 1.<br><br>Router(config)# <b>interface ethernet 1/1/0</b><br>Router(config-if)#                       |

**Step 3** Assign an IP address and subnet mask to the interface (if IP routing is enabled on the system) by using the **ip address** subcommand, as in the following example:

```
Router(config-if)# ip address 10.0.0.0 10.255.255.255
```

- Step 4** Add any additional configuration subcommands required to enable routing protocols and set the interface characteristics.
- Step 5** Re-enable the interfaces using the **no shutdown** command. (See the [“Shutting Down an Interface” section on page 4-2.](#))
- Step 6** Configure all additional port adapter interfaces as required.
- Step 7** After including all of the configuration subcommands to complete your configuration, press **Ctrl-Z**—hold down the **Control** key while you press **Z**—or enter **end** or **exit** to exit configuration mode and return to the EXEC command interpreter prompt.

**Step 8** Write the new configuration to NVRAM as follows:

```
Router# copy running-config startup-config
[OK]
Router#
```

This completes the procedure for creating a basic configuration.

## Checking the Configuration

After configuring the new interface, use the **show** commands to display the status of the new interface or all interfaces, and use the **ping** command to check connectivity. This section includes the following subsections:

- [Using show Commands to Verify the New Interface Status, page 4-10](#)
- [Using the ping Command to Verify Network Connectivity, page 4-24](#)

## Using show Commands to Verify the New Interface Status

[Table 4-4](#) demonstrates how you can use the **show** commands to verify that new interfaces are configured and operating correctly and that the PA-8E appears in them correctly. Sample displays of the output of selected **show** commands appear in the sections that follow. For complete command descriptions and examples, refer to the publications listed in the “[Related Documentation](#)” section on [page viii](#).



### Note

The outputs that appear in this document may not match the output you receive when running these commands. The outputs in this document are examples only.

**Table 4-4** Using show Commands

| Command                                                                                                        | Function                                                                                                                                                                   | Example                         |
|----------------------------------------------------------------------------------------------------------------|----------------------------------------------------------------------------------------------------------------------------------------------------------------------------|---------------------------------|
| <b>show version</b> or<br><b>show hardware</b>                                                                 | Displays system hardware configuration, the number of each interface type installed, Cisco IOS software version, names and sources of configuration files, and boot images | Router# <b>show version</b>     |
| <b>show controllers</b>                                                                                        | Displays all the current interface processors and their interfaces                                                                                                         | Router# <b>show controllers</b> |
| <b>show diag slot</b><br><br>Note The <i>slot</i> argument is not required with Catalyst 5000 family switches. | Displays types of port adapters installed in your system and information about a specific port adapter slot, interface processor slot, or chassis slot                     | Router# <b>show diag 2</b>      |

Table 4-4 Using show Commands (continued)

| Command                                                                                                                                 | Function                                                                                                                                               | Example                                     |
|-----------------------------------------------------------------------------------------------------------------------------------------|--------------------------------------------------------------------------------------------------------------------------------------------------------|---------------------------------------------|
| <b>show interfaces</b> <i>type 0 or 1/</i><br><i>interface-port-number</i>                                                              | Displays status information about a specific type of interface (for example, serial) on a Catalyst RSM/VIP2                                            | Router# <b>show interfaces serial 1/0</b>   |
| <b>show interfaces</b> <i>type 3/interface-port-</i><br><i>number</i>                                                                   | Displays status information about a specific type of interface (for example, serial) in a Cisco 7120 series router                                     | Router# <b>show interfaces serial 3/1</b>   |
| <b>show interfaces</b> <i>type 4/interface-port-</i><br><i>number</i>                                                                   | Displays status information about a specific type of interface (for example, serial) in a Cisco 7140 series router                                     | Router# <b>show interfaces serial 4/1</b>   |
| <b>show interfaces</b> <i>type</i><br><i>port-adapter-slot-number/</i><br><i>interface-port-number</i>                                  | Displays status information about a specific type of interface (for example, serial) in a Cisco 7200 series router or Cisco 7200 VXR router            | Router# <b>show interfaces serial 1/0</b>   |
| <b>show interfaces</b> <i>type 1/interface-port-</i><br><i>number</i>                                                                   | Displays status information about a specific type of interface (for example, serial) in a Cisco uBR7223 router                                         | Router# <b>show interfaces serial 1/1</b>   |
| <b>show interfaces</b> <i>type 1 or 2/</i><br><i>interface-port-number</i>                                                              | Displays status information about a specific type of interface (for example, serial) in a Cisco uBR7246 router                                         | Router# <b>show interfaces serial 2/0</b>   |
| <b>show interfaces</b> <i>type interface-processor-</i><br><i>slot-number/port-adapter-slot-number/</i><br><i>interface-port-number</i> | Displays status information about a specific type of interface (for example, serial) on a VIP in a Cisco 7000 series or Cisco 7500 series router       | Router# <b>show interfaces serial 3/1/0</b> |
| <b>show interfaces</b> <i>type</i><br><i>slot-number/interface-port-number</i>                                                          | Displays status information about a specific type of interface (for example, serial) on a Cisco 7201 router, Cisco 7301 router or Cisco 7401ASR router | Router# <b>show interfaces serial 1/0</b>   |
| <b>show interfaces</b> <i>type 2 or 3 or 4 or 5/</i><br><i>interface-port-number</i>                                                    | Displays status information about a serial interface on a Cisco 7304 PCI Port Adapter Carrier Card in a Cisco 7304 router                              | Router# <b>show interfaces ethernet 3/0</b> |
| <b>show protocols</b>                                                                                                                   | Displays protocols configured for the entire system and for specific interfaces                                                                        | Router# <b>show protocols</b>               |

Table 4-4 Using show Commands (continued)

| Command                    | Function                                   | Example                            |
|----------------------------|--------------------------------------------|------------------------------------|
| <b>show running-config</b> | Displays the running configuration file    | Router# <b>show running-config</b> |
| <b>show startup-config</b> | Displays the configuration stored in NVRAM | Router# <b>show startup-config</b> |

If an interface is shut down and you configured it as up, or if the displays indicate that the hardware is not functioning properly, ensure that the interface is properly connected and terminated. If you still have problems bringing up the interface, contact a service representative for assistance. This section includes the following subsections:

- [Using the show version or show hardware Commands, page 4-12](#)
- [Using the show diag Command, page 4-15](#)
- [Using the show interfaces Command, page 4-18](#)

Choose the subsection appropriate for your system. Proceed to the “[Using the ping Command to Verify Network Connectivity](#)” section on [page 4-24](#) when you have finished using the **show** commands.

## Using the show version or show hardware Commands

Display the configuration of the system hardware, the number of each interface type installed, the Cisco IOS software version, the names and sources of configuration files, and the boot images, using the **show version** (or **show hardware**) command.

The following examples show output for the **show version** command on some of the platforms that support the PA-8E.



### Note

The outputs that appear in this document may not match the output you receive when running these commands. The outputs in this document are examples only.

The following sections provide platform-specific output examples using the **show version** command:

- [Catalyst RSM/VIP2 in Catalyst 5000 Family Switches—Example Output of the show version Command, page 4-13](#)
- [Cisco 7200 Series and Cisco uBR7200 Series Routers—Example Output of the show version Command, page 4-13](#)
- [Cisco 7201 Router—Example Output of the show version Command, page 4-14](#)
- [Cisco 7401ASR Router—Example Output of the show version Command, page 4-14](#)
- [VIP in Cisco 7000 Series Routers and Cisco 7500 Series Routers—Example Output of the show version Command, page 4-15](#)

### Catalyst RSM/VIP2 in Catalyst 5000 Family Switches—Example Output of the show version Command

Following is an example of the **show version** command from a Catalyst 5000 family switch with a PA-8E installed:

```
Router# show version

Cisco Internetwork Operating System Software
IOS (tm) GS Software (RSP-A), Version 12.0(471) [mpo 105]
Copyright (c) 1986-1995 by cisco Systems, Inc.
Image text-base: 0x600088A0, data-base: 0x605A4000

ROM: System Bootstrap, Version 5.3(16645)

honda uptime is 4 hours, 22 minutes
System restarted by reload
System image file is "slot0:rsp-a111-1", booted via slot0

cisco RSP2 (R4600) processor with 32768K bytes of memory.
R4600 processor, Implementation 32, Revision 2.0
Last reset from power-on
G.703/E1 software, Version 1.0.
Bridging software.
X.25 software, Version 2.0, NET2, BFE and GOSIP compliant.
Chassis Interface.
1 VIP2 controllers (16 Ethernet).
16 Ethernet/IEEE 802.3 interfaces.
125K bytes of non-volatile configuration memory.

20480K bytes of Flash PCMCIA card at slot 0 (Sector size 128K).
8192K bytes of Flash internal SIMM (Sector size 256K).
No slave installed in slot 6.
Configuration register is 0x2
```

### Cisco 7200 Series and Cisco uBR7200 Series Routers—Example Output of the show version Command

Following is an example of the **show version** command from a Cisco 7200 series router with a PA-8E installed:

```
Router# show version

Cisco Internetwork Operating System Software
IOS (tm) 7200 Software (C7200-J-M), Version 11.1(472) [biff 105]
Copyright (c) 1986-1996 by cisco Systems, Inc.
Image text-base: 0x600088A0, data-base: 0x605A4000

ROM: System Bootstrap, Version 12.0(10979) RELEASED SOFTWARE

Router uptime is 8 hours, 22 minutes
System restarted by reload
System image file is "slot0:c7200-j-mz.960421", booted via slot0

cisco 7200 (R4700) processor with 22528K/10240K bytes of memory.
R4700 processor, Implementation 33, Revision 1.0
Last reset from power-on
Bridging software.
X.25 software, Version 2.0, NET2, BFE and GOSIP compliant.
Chassis Interface.
4 Ethernet/IEEE 802.3 interfaces.
5 FastEthernet/IEEE 802.3 interfaces.
125K bytes of non-volatile configuration memory.
```

```
20480K bytes of Flash PCMCIA card at slot 0 (Sector size 128K).
8192K bytes of Flash internal SIMM (Sector size 256K).
Configuration register is 0x2
```

### Cisco 7201 Router—Example Output of the show version Command

Following is an example of the **show version** command from a Cisco 7201 router:

```
Router# show version
Cisco IOS Software, 7200 Software (C7200P-ADVENTERPRISEK9-M), Version
12.4(biffDEV.061001), INTERIM SOFTWARE Copyright (c) 1986-2006 by Cisco Systems, Inc.
Compiled Sun 01-Oct-06 23:42 by biff
ROM: System Bootstrap, Version 12.4(4r)XD5, RELEASE SOFTWARE (fc1)
BOOTLDR: Cisco IOS Software, 7200 Software (C7200P-KBOOT-M), Version 12.4(TAZ3DEV.060927),
INTERIM SOFTWARE
c7201alphal uptime is 5 days, 18 hours, 32 minutes System returned to ROM by power-on
System image file is "disk0:c7200p-adventerprisek9-mz.2006-10-01.biffdev"
This product contains cryptographic features and is subject to United States and local
country laws governing import, export, transfer and use. Delivery of Cisco cryptographic
products does not imply third-party authority to import, export, distribute or use
encryption.
Importers, exporters, distributors and users are responsible for compliance with U.S. and
local country laws. By using this product you agree to comply with applicable laws and
regulations. If you are unable to comply with U.S. and local laws, return this product
immediately.
A summary of U.S. laws governing Cisco cryptographic products may be found at:
http://www.cisco.com/wwl/export/crypto/tool/stqrg.html
If you require further assistance please contact us by sending email to export@cisco.com.
Cisco 7201 (c7201) processor (revision A) with 917504K/65536K bytes of memory.
Processor board ID 22222222222222
MPC7448 CPU at 1666Mhz, Implementation 0, Rev 2.2
1 slot midplane, Version 2.255
Last reset from power-on
1 FastEthernet interface
4 Gigabit Ethernet interfaces
2045K bytes of NVRAM.
62443K bytes of USB Flash usbflash0 (Read/Write)
250880K bytes of ATA PCMCIA card at slot 0 (Sector size 512 bytes).
65536K bytes of Flash internal SIMM (Sector size 512K).
Configuration register is 0x2
```

### Cisco 7401ASR Router—Example Output of the show version Command

Following is an example of the **show version** command from a Cisco 7401ASR router with a PA-8E installed:

```
Router# show version

Cisco Internetwork Operating System Software
IOS (tm) 7401ASR Software (C7401ASR-J-M), Version 11.1(472) [biff 105]
Copyright (c) 1986-1996 by cisco Systems, Inc.
Image text-base: 0x600088A0, data-base: 0x605A4000

ROM: System Bootstrap, Version 12.0(10979) RELEASED SOFTWARE

Router uptime is 8 hours, 22 minutes
System restarted by reload
System image file is "slot0:c7401ASR-j-mz.960421", booted via slot0

cisco 7401ASR (R4700) processor with 22528K/10240K bytes of memory.
R4700 processor, Implementation 33, Revision 1.0
```

```

Last reset from power-on
Bridging software.
X.25 software, Version 2.0, NET2, BFE and GOSIP compliant.
Chassis Interface.
4 Ethernet/IEEE 802.3 interfaces.
5 FastEthernet/IEEE 802.3 interfaces.
125K bytes of non-volatile configuration memory.

20480K bytes of Flash PCMCIA card at slot 0 (Sector size 128K).
8192K bytes of Flash internal SIMM (Sector size 256K).
Configuration register is 0x2

```

## VIP in Cisco 7000 Series Routers and Cisco 7500 Series Routers—Example Output of the show version Command

Following is an example of the **show version** command from a Cisco 7500 series router with a PA-8E installed:

```

Router# show version

Cisco Internetwork Operating System Software
IOS (tm) GS Software (RSP-A), Version 12.0(471) [mpo 105]
Copyright (c) 1986-1995 by cisco Systems, Inc.
Image text-base: 0x600088A0, data-base: 0x605A4000

ROM: System Bootstrap, Version 5.3(16645)

honda uptime is 4 hours, 22 minutes
System restarted by reload
System image file is "slot0:rsp-a111-1", booted via slot0

cisco RSP2 (R4600) processor with 32768K bytes of memory.
R4600 processor, Implementation 32, Revision 2.0
Last reset from power-on
G.703/E1 software, Version 1.0.
Bridging software.
X.25 software, Version 2.0, NET2, BFE and GOSIP compliant.
Chassis Interface.
1 VIP2 controllers (16 Ethernet).
16 Ethernet/IEEE 802.3 interfaces.
125K bytes of non-volatile configuration memory.

20480K bytes of Flash PCMCIA card at slot 0 (Sector size 128K).
8192K bytes of Flash internal SIMM (Sector size 256K).
No slave installed in slot 6.
Configuration register is 0x2

```

## Using the show diag Command

Display the types of port adapters installed in your system (and specific information about each) using the **show diag slot** command, where *slot* is the *port adapter slot* in a Catalyst 5000 family switch, Cisco 7100 series router, Cisco 7200 series router, Cisco 7200 VXR router, Cisco uBR7200 series router, Cisco 7201 router, Cisco 7301 router, and Cisco 7401ASR router, the *module slot* in a Cisco 7304 PCI Port Adapter Carrier Card in a Cisco 7304 router, and the *interface processor slot* in a Cisco 7000 series router or Cisco 7500 series router with a VIP.



### Note

The outputs that appear in this document may not match the output you receive when running these commands. The outputs in this document are examples only.

**Note**

The *slot* argument is not required for Catalyst 5000 family switches.

The following sections provide platform-specific output examples using the **show diag** command:

- [Catalyst RSM/VIP2 in Catalyst 5000 Family Switches—Example Output of the show diag Command, page 4-16](#)
- [Cisco 7200 Series Routers and Cisco uBR7200 Series Routers—Example Output of the show diag Command, page 4-16](#)
- [Cisco 7201 Router—Example Output of the show diag Command, page 4-17](#)
- [Cisco 7401ASR Router—Example Output of the show diag Command, page 4-17](#)
- [VIP in Cisco 7000 Series Routers and Cisco 7500 Series Routers—Example Output of the show diag Command, page 4-18](#)

### Catalyst RSM/VIP2 in Catalyst 5000 Family Switches—Example Output of the show diag Command

Following is an example of the **show diag** command that shows a PA-8E installed in a Catalyst RSM/VIP2:

```
Router# show diag 0
Slot 0:
Ethernet port adapter, 8 ports
Port adapter is analyzed
Port adapter insertion time 2d09h ago
Hardware revision 1.14 Board revision A0
Serial number 4294967295 Part number 73-1556-04
Test history 0x0 RMA number 00-00-00
EEPROM format version 1
EEPROM contents (hex):
0x20:01 01 01 0E FF FF FF FF 49 06 14 04 00 00 00 00
0x30:50 00 00 00 FF FF FF FF FF FF FF FF FF FF FF FF

Slot database information:
Flags: 0x4 Insertion time: 0x1DEC (2d00h ago)
```

### Cisco 7200 Series Routers and Cisco uBR7200 Series Routers—Example Output of the show diag Command

Following is an example of the **show diag** command that shows a PA-8E installed in port adapter slot 4 of a Cisco 7200 series router:

```
Router# show diag 4
Slot 4:
Ethernet port adapter, 8 ports
Port adapter is analyzed
Port adapter insertion time 2d09h ago
Hardware revision 1.1 Board revision A0
Serial number 4294967295 Part number 73-1556-04
Test history 0x0 RMA number 00-00-00
EEPROM format version 1
EEPROM contents (hex):
0x20: 01 02 01 01 FF FF FF FF 49 06 14 04 00 00 00 00
0x30: 50 00 00 00 FF FF FF FF FF FF FF FF FF FF FF
```

Port adapters used with the Cisco 7200 VXR and Cisco uBR7246 VXR routers require the correct base hardware revision to function. The following error message will occur on bootup if the incorrect hardware revision is used:

PA-3-REVNOTSUPPORTED:PA in slot 1 (Ethernet) requires base h/w revision of (1.14) for this chassis

Use the **show diag** command to display the hardware revision.



**Note**

For complete command descriptions and examples for Cisco 7200 series routers, Cisco 7100 series routers, and Cisco uBR7200 series universal broadband routers, refer to the publications listed in the [“Related Documentation”](#) section on page viii.

### Cisco 7201 Router—Example Output of the show diag Command

Following is an example of the **show diag** command from a Cisco 7201 router:

```
Router# show diag 1
Slot 1:
 Dual OC3 POS Port adapter, 2 ports
 Port adapter is analyzed
 Port adapter insertion time 00:02:19 ago
 EEPROM contents at hardware discovery:
 Hardware Revision : 1.0
 PCB Serial Number : JAE07520DYL
 Part Number : 73-8220-02
 Board Revision : A0
 RMA Test History : 00
 RMA Number : 0-0-0-0
 RMA History : 00
 Deviation Number : 0
 Product (FRU) Number : PA-POS-20C3
 Top Assy. Part Number : 800-21857-02
 EEPROM format version 4
 EEPROM contents (hex):
 0x00: 04 FF 40 03 E3 41 01 00 C1 8B 4A 41 45 30 37 35
 0x10: 32 30 44 59 4C 82 49 20 1C 02 42 41 30 03 00 81
 0x20: 00 00 00 00 04 00 88 00 00 00 00 CB 94 50 41 2D
 0x30: 50 4F 53 2D 32 4F 43 33 20 20 20 20 20 20 20 20
 0x40: 20 C0 46 03 20 00 55 61 02 FF FF FF FF FF FF FF
 0x50: FF FF FF FF FF FF FF FF FF FF FF FF FF FF FF FF
 0x60: FF FF FF FF FF FF FF FF FF FF FF FF FF FF FF FF
 0x70: FF FF FF FF FF FF FF FF FF FF FF FF FF FF FF FF
```

### Cisco 7401ASR Router—Example Output of the show diag Command

Following is an example of the **show diag** command that shows a PA-8E installed in port adapter slot 1 of a Cisco 7401ASR router:

```
Router# show diag 1

Slot 1:
Ethernet port adapter, 8 ports
Port adapter is analyzed
Port adapter insertion time 2d09h ago
Hardware revision 1.1 Board revision A0
Serial number 4294967295 Part number 73-1556-04
Test history 0x0 RMA number 00-00-00
EEPROM format version 1
EEPROM contents (hex):
0x20: 01 02 01 01 FF FF FF FF 49 06 14 04 00 00 00 00
0x30: 50 00 00 00 FF FF FF FF FF FF FF FF FF FF FF FF
```

## VIP in Cisco 7000 Series Routers and Cisco 7500 Series Routers—Example Output of the show diag Command

Following is an example of the **show diag** command that shows a PA-8E installed in port adapter slot 0 on a VIP2 in interface processor slot 4:

```
Router# show diag 4
Slot 4:
Ethernet port adapter, 8 ports
Port adapter is analyzed
Port adapter insertion time 2d09h ago
Hardware revision 1.14 Board revision A0
Serial number 4294967295 Part number 73-1556-04
Test history 0x0 RMA number 00-00-00
EEPROM format version 1
EEPROM contents (hex):
0x20:01 01 01 0E FF FF FF FF 49 06 14 04 00 00 00 00
0x30:50 00 00 00 FF FF FF FF FF FF FF FF FF FF FF FF

Slot database information:
Flags: 0x4 Insertion time: 0x1DEC (2d00h ago)

Controller Memory Size: 8 MBytes

PA Bay 1 Information:
Ethernet PA, 8 ports
EEPROM format version 1
HW rev 1.1, Board revision 80
Serial number: 02825590 Part number: 73-1391-04
```



### Note

For complete VIP command descriptions and examples, refer to the publications listed in the [“Related Documentation”](#) section on page viii.

## Using the show interfaces Command

Display status information (including the physical slot and interface address) for the interfaces you specify using the **show interfaces** command.

With the **show interfaces** command, use arguments such as the interface type (**ethernet**, and so forth) and the port adapter and port numbers (port adapter/port) to display information about a specific Ethernet 10BaseT interface only.

For complete descriptions of interface subcommands and the configuration options available for the individual platforms, refer to the publications listed in the [“Related Documentation”](#) section on page viii.



### Note

The outputs that appear in this document may not match the output you receive when running these commands. The outputs in this document are examples only.

The following sections provide platform-specific output examples using the **show interfaces** command:

- [Catalyst RSM/VIP2 in Catalyst 5000 Family Switches—Example Output of the show interfaces Command, page 4-19](#)
- [Cisco 7200 Series and Cisco uBR7200 Series Routers—Example Output of the show interfaces Command, page 4-20](#)
- [Cisco 7201 Router—Example Output of the show interfaces Command, page 4-22](#)
- [Cisco 7401ASR Router—Example Output of the show interfaces Command, page 4-22](#)
- [VIP in Cisco 7000 Series Routers or Cisco 7500 Series Routers—Example Output of the show interfaces Command, page 4-23](#)

### Catalyst RSM/VIP2 in Catalyst 5000 Family Switches—Example Output of the show interfaces Command

Following are examples of the **show interfaces ethernet** command from a Catalyst 5000 family switch. In these examples, the eight serial interfaces (0 to 7) are on a port adapter in port adapter slot 0 of a Catalyst RSM/VIP2; also, most of the status information for each interface is omitted. (Interfaces are administratively shut down until you enable them.)

```
Router# show interfaces ethernet 0/0
Ethernet0/0 is administratively down, line protocol is down
 Hardware is cyBus Ethernet, address is 0000.0ca5.2300 (bia 0000.0ca5.2389)
 MTU 1500 bytes, BW 10000 Kbit, DLY 1000 usec, rely 255/255, load 1/255
 Encapsulation ARPA, loopback not set, keepalive set (10 sec)
(display text omitted)
```

```
Router# show interfaces ethernet 0/1
Ethernet0/1 is administratively down, line protocol is down
 Hardware is cyBus Ethernet, address is 0000.0ca5.2301 (bia 0000.0ca5.238a)
 MTU 1500 bytes, BW 10000 Kbit, DLY 1000 usec, rely 255/255, load 1/255
 Encapsulation ARPA, loopback not set, keepalive set (10 sec)
(display text omitted)
```

```
Router# show interfaces ethernet 0/2
Ethernet0/2 is administratively down, line protocol is down
 Hardware is cyBus Ethernet, address is 0000.0ca5.2302 (bia 0000.0ca5.238b)
 MTU 1500 bytes, BW 10000 Kbit, DLY 1000 usec, rely 255/255, load 1/255
 Encapsulation ARPA, loopback not set, keepalive set (10 sec)
(display text omitted)
```

```
Router# show interfaces ethernet 0/3
Ethernet0/3 is administratively down, line protocol is down
 Hardware is cyBus Ethernet, address is 0000.0ca5.2303 (bia 0000.0ca5.238c)
 MTU 1500 bytes, BW 10000 Kbit, DLY 1000 usec, rely 255/255, load 1/255
 Encapsulation ARPA, loopback not set, keepalive set (10 sec)
(display text omitted)
```

```
Router# show interfaces ethernet 0/4
Ethernet0/4 is administratively down, line protocol is down
 Hardware is cyBus Ethernet, address is 0000.0ca5.2304 (bia 0000.0ca5.238d)
 MTU 1500 bytes, BW 10000 Kbit, DLY 1000 usec, rely 255/255, load 1/255
 Encapsulation ARPA, loopback not set, keepalive set (10 sec)
(display text omitted)
```

```
Router# show interfaces ethernet 0/5
Ethernet0/5 is administratively down, line protocol is down
 Hardware is cyBus Ethernet, address is 0000.0ca5.2305 (bia 0000.0ca5.238e)
 MTU 1500 bytes, BW 10000 Kbit, DLY 1000 usec, rely 255/255, load 1/255
 Encapsulation ARPA, loopback not set, keepalive set (10 sec)
(display text omitted)
```

```
Router# show interfaces ethernet 0/6
Ethernet0/6 is administratively down, line protocol is down
 Hardware is cyBus Ethernet, address is 0000.0ca5.2306 (bia 0000.0ca5.238f)
 MTU 1500 bytes, BW 10000 Kbit, DLY 1000 usec, rely 255/255, load 1/255
 Encapsulation ARPA, loopback not set, keepalive set (10 sec)
(display text omitted)
```

```
Router# show interfaces ethernet 0/7
Ethernet0/7 is administratively down, line protocol is down
 Hardware is cyBus Ethernet, address is 0000.0ca5.2307 (bia 0000.0ca5.2391)
 MTU 1500 bytes, BW 10000 Kbit, DLY 1000 usec, rely 255/255, load 1/255
 Encapsulation ARPA, loopback not set, keepalive set (10 sec)
```

The following example of the **show interfaces ethernet** command shows all of the information specific to the first PA-8E interface port (interface port 0) in port adapter slot 1:

```
Router# show interfaces ethernet 1/0
Ethernet1/0 is administratively down, line protocol is down
 Hardware is cyBus Ethernet, address is 0000.0ca5.2309 (bia 0000.0ca5.2392)
 MTU 1500 bytes, BW 10000 Kbit, DLY 1000 usec, rely 255/255, load 1/255
 Encapsulation ARPA, loopback not set, keepalive set (10 sec)
 ARP type: ARPA, ARP Timeout 4:00:00
 Last input never, output never, output hang never
 Last clearing of "show interface" counters 2:56:26
 Output queue 0/40, 0 drops; input queue 0/75, 0 drops
 5 minute input rate 0 bits/sec, 0 packets/sec
 5 minute output rate 0 bits/sec, 0 packets/sec
 0 packets input, 0 bytes, 0 no buffer
 Received 0 broadcasts, 0 runts, 0 giants
 0 input errors, 0 CRC, 0 frame, 0 overrun, 0 ignored, 0 abort
 0 input packets with dribble condition detected
 0 packets output, 0 bytes, 0 underruns
 0 output errors, 0 collisions, 0 interface resets, 0 restarts
 0 output buffer failures, 0 output buffers swapped out
```

## Cisco 7200 Series and Cisco uBR7200 Series Routers—Example Output of the show interfaces Command

Following are examples of the **show interfaces** command from a Cisco 7200 series router or a Cisco uBR7200 series router. In these examples, the eight serial interfaces (0 to 7) are on a port adapter in port adapter slot 2; also, most of the status information for each interface is omitted. (Interfaces are administratively shut down until you enable them.)

```
Router# show interfaces ethernet 2/0
Ethernet2/0 is administratively down, line protocol is down
 Hardware is AmdP2 Ethernet, address is 10.0.0.0 10.255.255.255 (bia 0000.0ca5.2389)
 MTU 1500 bytes, BW 10000 Kbit, DLY 1000 usec, rely 255/255, load 1/255
 Encapsulation ARPA, loopback not set, keepalive set (10 sec)
(display text omitted)
```

```
Router# show interfaces ethernet 2/1
Ethernet2/1 is administratively down, line protocol is down
 Hardware is AmdP2 Ethernet, address is 10.0.0.0 10.255.255.255 (bia 0000.0ca5.238a)
 MTU 1500 bytes, BW 10000 Kbit, DLY 1000 usec, rely 255/255, load 1/255
 Encapsulation ARPA, loopback not set, keepalive set (10 sec)
(display text omitted)Router# sh int e 2/2
```

```
Ethernet2/2 is administratively down, line protocol is down
 Hardware is AmdP2 Ethernet, address is 10.0.0.0 10.255.255.255 (bia 0000.0ca5.238b)
 MTU 1500 bytes, BW 10000 Kbit, DLY 1000 usec, rely 255/255, load 1/255
 Encapsulation ARPA, loopback not set, keepalive set (10 sec)
(display text omitted)
```

```
Router# show interfaces ethernet 2/3
Ethernet2/3 is administratively down, line protocol is down
 Hardware is AmdP2 Ethernet, address is 10.0.0.0 10.255.255.255 (bia 0000.0ca5.238c)
 MTU 1500 bytes, BW 10000 Kbit, DLY 1000 usec, rely 255/255, load 1/255
 Encapsulation ARPA, loopback not set, keepalive set (10 sec)
(display text omitted)
```

```
Router# show interfaces ethernet 2/4
Ethernet2/4 is administratively down, line protocol is down
 Hardware is AmdP2 Ethernet, address is 10.0.0.0 10.255.255.255 (bia 0000.0ca5.238d)
 MTU 1500 bytes, BW 10000 Kbit, DLY 1000 usec, rely 255/255, load 1/255
 Encapsulation ARPA, loopback not set, keepalive set (10 sec)
(display text omitted)
```

```
Router# show interfaces ethernet 2/5
Ethernet2/5 is administratively down, line protocol is down
 Hardware is AmdP2 Ethernet, address is 10.0.0.0 10.255.255.255 (bia 0000.0ca5.238e)
 MTU 1500 bytes, BW 10000 Kbit, DLY 1000 usec, rely 255/255, load 1/255
 Encapsulation ARPA, loopback not set, keepalive set (10 sec)
(display text omitted)
```

```
Router# show interfaces ethernet 2/6
Ethernet2/6 is administratively down, line protocol is down
 Hardware is AmdP2 Ethernet, address is 10.0.0.0 10.255.255.255 (bia 0000.0ca5.238f)
 MTU 1500 bytes, BW 10000 Kbit, DLY 1000 usec, rely 255/255, load 1/255
 Encapsulation ARPA, loopback not set, keepalive set (10 sec)
(display text omitted)
```

```
Router# show interfaces ethernet 2/7
Ethernet2/7 is administratively down, line protocol is down
 Hardware is AmdP2 Ethernet, address is 10.0.0.0 10.255.255.255 (bia 0000.0ca5.2391)
 MTU 1500 bytes, BW 10000 Kbit, DLY 1000 usec, rely 255/255, load 1/255
 Encapsulation ARPA, loopback not set, keepalive set (10 sec)
(display text omitted)
```

The following example of the **show interfaces ethernet** command shows all of the information specific to the first 8E interface port (interface port 0) in port adapter slot 2:

```
Router# show interfaces ethernet 2/0
Ethernet2/0 is administratively down, line protocol is down
 Hardware is AmdP2 Ethernet, address is 10.0.0.0 10.255.255.255 (bia 0000.0ca5.2392)
 MTU 1500 bytes, BW 10000 Kbit, DLY 1000 usec, rely 255/255, load 1/255
 Encapsulation ARPA, loopback not set, keepalive set (10 sec)
 ARP type: ARPA, ARP Timeout 4:00:00
 Last input never, output never, output hang never
 Last clearing of "show interface" counters 2:56:26
 Output queue 0/40, 0 drops; input queue 0/75, 0 drops
 5 minute input rate 0 bits/sec, 0 packets/sec
 5 minute output rate 0 bits/sec, 0 packets/sec
 0 packets input, 0 bytes, 0 no buffer
 Received 0 broadcasts, 0 runts, 0 giants
 0 input errors, 0 CRC, 0 frame, 0 overrun, 0 ignored, 0 abort
 0 input packets with dribble condition detected
 0 packets output, 0 bytes, 0 underruns
 0 output errors, 0 collisions, 0 interface resets, 0 restarts
```

### Cisco 7201 Router—Example Output of the show interfaces Command

Following is an example of the **show interfaces** command from a Cisco 7201 router:

```
Router# show interfaces
GigabitEthernet0/0 is up, line protocol is up
 Hardware is MV64460 Internal MAC, address is 0019.56c5.2adb (bia
0019.56c5.2adb)
 Internet address is 209.165.200.225
 MTU 1500 bytes, BW 1000000 Kbit, DLY 10 usec,
 reliability 255/255, txload 1/255, rxload 45/255
 Encapsulation ARPA, loopback not set
 Keepalive set (10 sec)
 Full-duplex, 1000Mb/s, media type is RJ45
 output flow-control is XON, input flow-control is XON
 ARP type: ARPA, ARP Timeout 04:00:00
 Last input 00:07:03, output 00:00:07, output hang never
 Last clearing of "show interface" counters 00:00:04
 Input queue: 0/75/0/0 (size/max/drops/flushes); Total output drops: 0
 Queueing strategy: fifo
 Output queue: 0/40 (size/max)
 5 minute input rate 180240000 bits/sec, 430965 packets/sec
 5 minute output rate 0 bits/sec, 0 packets/sec
 2222975 packets input, 133378500 bytes, 0 no buffer
 Received 0 broadcasts, 0 runts, 0 giants, 0 throttles
 0 input errors, 0 CRC, 0 frame, 0 overrun, 0 ignored
 0 watchdog, 0 multicast, 0 pause input
 0 input packets with dribble condition detected
 0 packets output, 0 bytes, 0 underruns
 0 output errors, 0 collisions, 0 interface resets
 0 babbles, 0 late collision, 0 deferred
 0 lost carrier, 0 no carrier, 0 pause output
 0 output buffer failures, 0 output buffers swapped out
```

### Cisco 7401ASR Router—Example Output of the show interfaces Command

Following is an example of the **show interfaces ethernet** command from a Cisco 7401ASR router:

```
Router# show interfaces ethernet 1/0
POS1/0 is up, line protocol is up
Hardware is Packet over Sonet
Internet address is 1.1.1.2/8
MTU 4470 bytes, BW 155000 Kbit, DLY 100 usec,
reliability 255/255, txload 1/255, rxload 1/255
Encapsulation HDLC, crc 16, loopback not set
Keepalive not set
Scramble disabled
Last input 00:00:16, output never, output hang never
Last clearing of "show interface" counters never
Queueing strategy: fifo
Output queue 0/40, 0 drops; input queue 0/75, 0 drops
5 minute input rate 0 bits/sec, 0 packets/sec
5 minute output rate 0 bits/sec, 0 packets/sec
7 packets input, 1158 bytes, 0 no buffer
Received 0 broadcasts, 0 runts, 0 giants, 0 throttles
0 parity
10 input errors, 10 CRC, 0 frame, 0 overrun, 0 ignored, 0 abort
7 packets output, 1158 bytes, 0 underruns
0 output errors, 0 applique, 1 interface resets
0 output buffer failures, 0 output buffers swapped out
0 carrier transitions
```

## VIP in Cisco 7000 Series Routers or Cisco 7500 Series Routers—Example Output of the show interfaces Command

Following are examples of the **show interfaces** command used with the VIP. In these examples, the eight serial interfaces (0 to 7) are on a port adapter in port adapter slot 0 of a VIP in interface processor slot 3; also, most of the status information for each interface is omitted. (Interfaces are administratively shut down until you enable them.)

```
Router# show interfaces ethernet 3/0/0
Ethernet3/0/0 is administratively down, line protocol is down
 Hardware is cyBus Ethernet, address is 0000.0ca5.2300 (bia 0000.0ca5.2389)
 MTU 1500 bytes, BW 10000 Kbit, DLY 1000 usec, rely 255/255, load 1/255
 Encapsulation ARPA, loopback not set, keepalive set (10 sec)
(display text omitted)
```

```
Router# show interfaces ethernet 3/0/1
Ethernet3/0/1 is administratively down, line protocol is down
 Hardware is cyBus Ethernet, address is 0000.0ca5.2301 (bia 0000.0ca5.238a)
 MTU 1500 bytes, BW 10000 Kbit, DLY 1000 usec, rely 255/255, load 1/255
 Encapsulation ARPA, loopback not set, keepalive set (10 sec)
(display text omitted)
```

```
Router# show interfaces ethernet 3/0/2
Ethernet3/0/2 is administratively down, line protocol is down
 Hardware is cyBus Ethernet, address is 0000.0ca5.2302 (bia 0000.0ca5.238b)
 MTU 1500 bytes, BW 10000 Kbit, DLY 1000 usec, rely 255/255, load 1/255
 Encapsulation ARPA, loopback not set, keepalive set (10 sec)
(display text omitted)
```

```
Router# show interfaces ethernet 3/0/3
Ethernet3/0/3 is administratively down, line protocol is down
 Hardware is cyBus Ethernet, address is 0000.0ca5.2303 (bia 0000.0ca5.238c)
 MTU 1500 bytes, BW 10000 Kbit, DLY 1000 usec, rely 255/255, load 1/255
 Encapsulation ARPA, loopback not set, keepalive set (10 sec)
(display text omitted)
```

```
Router# show interfaces ethernet 3/0/4
Ethernet3/0/4 is administratively down, line protocol is down
 Hardware is cyBus Ethernet, address is 0000.0ca5.2304 (bia 0000.0ca5.238d)
 MTU 1500 bytes, BW 10000 Kbit, DLY 1000 usec, rely 255/255, load 1/255
 Encapsulation ARPA, loopback not set, keepalive set (10 sec)
(display text omitted)
```

```
Router# show interfaces ethernet 3/0/5
Ethernet3/0/5 is administratively down, line protocol is down
 Hardware is cyBus Ethernet, address is 0000.0ca5.2305 (bia 0000.0ca5.238e)
 MTU 1500 bytes, BW 10000 Kbit, DLY 1000 usec, rely 255/255, load 1/255
 Encapsulation ARPA, loopback not set, keepalive set (10 sec)
(display text omitted)
```

```
Router# show interfaces ethernet 3/0/6
Ethernet3/0/6 is administratively down, line protocol is down
 Hardware is cyBus Ethernet, address is 0000.0ca5.2306 (bia 0000.0ca5.238f)
 MTU 1500 bytes, BW 10000 Kbit, DLY 1000 usec, rely 255/255, load 1/255
 Encapsulation ARPA, loopback not set, keepalive set (10 sec)
(display text omitted)
```

```
Router# show interfaces ethernet 3/0/7
Ethernet3/0/7 is administratively down, line protocol is down
 Hardware is cyBus Ethernet, address is 0000.0ca5.2307 (bia 0000.0ca5.2391)
 MTU 1500 bytes, BW 10000 Kbit, DLY 1000 usec, rely 255/255, load 1/255
 Encapsulation ARPA, loopback not set, keepalive set (10 sec)
```

The following example of the **show interfaces ethernet** command shows all of the information specific to the first PA-8E interface port (interface port 0) in chassis slot 3, port adapter slot 1:

```
Router# show interfaces ethernet 3/1/0
Ethernet3/1/0 is administratively down, line protocol is down
 Hardware is cyBus Ethernet, address is 0000.0ca5.2309 (bia 0000.0ca5.2392)
 MTU 1500 bytes, BW 10000 Kbit, DLY 1000 usec, rely 255/255, load 1/255
 Encapsulation ARPA, loopback not set, keepalive set (10 sec)
 ARP type: ARPA, ARP Timeout 4:00:00
 Last input never, output never, output hang never
 Last clearing of "show interface" counters 2:56:26
 Output queue 0/40, 0 drops; input queue 0/75, 0 drops
 5 minute input rate 0 bits/sec, 0 packets/sec
 5 minute output rate 0 bits/sec, 0 packets/sec
 0 packets input, 0 bytes, 0 no buffer
 Received 0 broadcasts, 0 runts, 0 giants
 0 input errors, 0 CRC, 0 frame, 0 overrun, 0 ignored, 0 abort
 0 input packets with dribble condition detected
 0 packets output, 0 bytes, 0 underruns
 0 output errors, 0 collisions, 0 interface resets, 0 restarts
 0 output buffer failures, 0 output buffers swapped out
```

Proceed to the next section, “[Using the ping Command to Verify Network Connectivity](#),” to check network connectivity of the PA-8E and switch or router.

## Using the ping Command to Verify Network Connectivity

Using the **ping** command, you can verify that an interface port is functioning properly. This section provides a brief description of this command. Refer to the publications listed in the “[Related Documentation](#)” section on page viii for detailed command descriptions and examples.

The **ping** command sends echo request packets out to a remote device at an IP address that you specify. After sending an echo request, the system waits a specified time for the remote device to reply. Each echo reply is displayed as an exclamation point (!) on the console terminal; each request that is not returned before the specified timeout is displayed as a period (.). A series of exclamation points (!!!!) indicates a good connection; a series of periods (.....) or the messages [timed out] or [failed] indicate a bad connection.

Following is an example of a successful **ping** command to a remote server with the address 10.0.0.10:

```
Router# ping 10.0.0.10 <Return>
Type escape sequence to abort.
Sending 5, 100-byte ICMP Echoes to 10.0.0.10, timeout is 2 seconds:
!!!!!
Success rate is 100 percent (5/5), round-trip min/avg/max = 1/15/64 ms
Router#
```

If the connection fails, verify that you have the correct IP address for the destination and that the device is active (powered on), and repeat the **ping** command.