

CISCO ETHERSWITCH 4- AND 9-PORT HIGH-SPEED WAN INTERFACE CARDS FOR CISCO 1800 (MODULAR), CISCO 2800, AND CISCO 3800 SERIES INTEGRATED SERVICES ROUTERS

PRODUCT OVERVIEW

The 4- and 9-port Cisco® EtherSwitch® 10/100 high-speed WAN interface cards (HWICs) supported on the Cisco 1800 (modular), Cisco 2800, and Cisco 3800 series integrated services routers offer small-to-large-size businesses and enterprise branch office customers the option to integrate switching and routing in one device. This combination offers ease of configuration, deployment, and management while using the powerful characteristics of Cisco routing and Cisco Catalyst® switching features.

The modular 4- and 9-port Cisco EtherSwitch HWICs provide line-rate Layer 2 switching across Ethernet ports using Cisco IOS® Catalyst Software. The 4-port Cisco EtherSwitch HWIC has four 10/100 switched Ethernet ports, with options for inline power support on all four ports. The 9-port Cisco EtherSwitch HWIC has nine 10/100 switched Ethernet ports, with options for inline power support on 8 of the 9 ports. The ninth port does not support inline power but can be used as a regular switch port for trunking and other normal data applications. Note: The optional inline power support on the 4- and 9-port HWICs is offered on the Cisco 2800 and Cisco 3800 series. It is not offered on the Cisco 1841 of the Cisco 1800 Series (modular). Features such as port autosensing, quality of service (QoS), VLAN support from 802.1P and 802.1Q standards, and 802.1D spanning tree protocols are standard on the Cisco EtherSwitch HWIC. The Cisco EtherSwitch HWICs are available in standard 4- or 9-port 10/100BASE-TX switch HWIC and Power-over-Ethernet (PoE) configurations. The PoE configurations consist of a 4- or 9-port 10/100BASE-TX switch and a 4- or 8-port inline power module daughter card. The power module daughter card houses a power controller for detecting, classifying, and enabling power on 802.3af-compliant powered devices attached to the HWICs. The inline powered version of the Cisco EtherSwitch HWIC can power Cisco IP phones, Cisco wireless access points, or any other IEEE 802.3af-compliant device. The optional inline power support on the 4- and 9-port HWICs on the Cisco 2800 and Cisco 3800 series of integrated services routers requires the use of a field-replaceable inline power supply. (Refer to Figure 1.)

Figure 1. 9- and 4-Port Cisco EtherSwitch HWICs for Cisco 1800 (modular), Cisco 2800, and Cisco 3800 Series Integrated Services Routers



Note: Support for HWICs on the Cisco 1800, Cisco 2800, and Cisco 3800 series and the support for inline power for the 4- and 9-port HWICs on the Cisco 2800 and Cisco 3800 series is a configuration option.

CISCO ETHERSWITCH HWIC SUMMARY

Table 1 gives the product numbers for the 4- and 9-port Cisco EtherSwitch HWICs.

Table 1. Product Numbers for 4- and 9-Port Cisco EtherSwitch HWICs

Product Number	Description
HWIC-4ESW	4-port Cisco EtherSwitch 10BASE-T/100BASE-TX autosensing HWIC
HWIC-4ESW-POE*	4-port Cisco EtherSwitch 10BASE-T/100BASE-TX autosensing HWIC with power daughter card
HWIC-D-9ESW	9-port Cisco EtherSwitch 10BASE-T/100BASE-TX autosensing HWIC
HWIC-D-9ESW-POE**	9-port Cisco EtherSwitch 10BASE-T/100BASE-TX autosensing HWIC with power daughter card

* This part number (HWIC-4ESW-POE) should be ordered only if you require in-line power. You must also order the matching internal power unit to support in-line power on a Cisco 2800 or Cisco 3800 router.

** This part number (HWIC-D-9ESW) should be ordered only if you require in-line power. You must also order the matching internal power unit to support in-line power on a Cisco 2800 or Cisco 3800 router.

Table 2 gives the power supply options for the Cisco 2800 and Cisco 3800 series to support inline power on the 4- and 9-port HWICs.

Table 2. Power Supply Product Numbers

Product Number	Description
PWR-2801-AC-IP=	Cisco 2801 AC inline power supply
PWR-2811-AC-IP=	Cisco 2811 AC inline power supply
PWR-2821-51-AC-IP=	Cisco 2821 and Cisco 2851 AC inline power supply
PWR-3825-AC-IP=	Cisco 3825 AC-IP power supply
PWR-3845-AC-IP=	Cisco 3845 AC-IP power supply

PLATFORM SUPPORT

Table 3 lists the supported platforms for the 4- and 9-port Cisco EtherSwitch HWICs.

Table 3. Supported Platforms for 4- and 9-Port Cisco EtherSwitch HWICs

Chassis	4-Port Cisco EtherSwitch HWIC	9-Port Cisco EtherSwitch HWIC	Internal Inline Power Supply (optional)
Cisco 1841	Yes, 2 HWICs per router	No	No
Cisco 2801	Yes, 2 HWICs per router	Yes, 2 HWICs per router	Yes
Cisco 2811	Yes, 2 HWICs per router	Yes, 2 HWICs per router	Yes
Cisco 2821	Yes, 2 HWICs per router	Yes, 2 HWICs per router	Yes
Cisco 2851	Yes, 2 HWICs per router	Yes, 2 HWICs per router	Yes
Cisco 3825	Yes, 2 HWICs per router	Yes, 2 HWICs per router	Yes
Cisco 3845	Yes, 2 HWICs per router	Yes, 2 HWICs per router	Yes

Note: The Cisco 2800 and Cisco 3800 series also offer bundles that already come with the inline power supply. The part numbers are CISCO2801-AC-IP, CISCO2811-AC-IP, CISCO2821-AC-IP, CISCO2851-AC-IP, CISCO3825-AC-IP, and CISCO3845-AC-IP. These bundles offer the router chassis with the inline power supply included to support inline power on the 4- and 9-port HWICs.

APPLICATIONS

Small Branch Data Only

Figure 2 shows an example of a deployment for a small-to-large enterprise branch office.

Figure 2. Typical Data-Only Deployment for a Small-to-Large Enterprise Branch Office

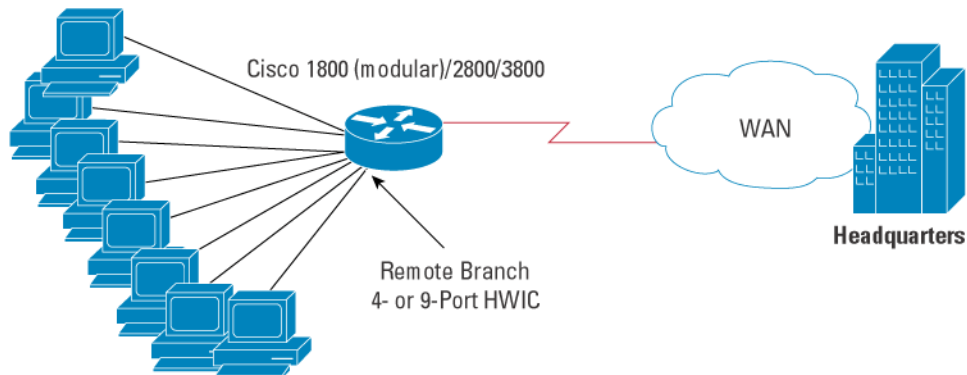

A Cisco EtherSwitch HWIC in an enterprise branch data deployment scenario provides the flexibility of integrated routing and switching functions in one unit for low port densities. This deployment provides high-speed connections between individual desktops, servers, and other network resources in a single unit for Layer 2 and allows WAN connection at Layer 3 through the router. The Cisco EtherSwitch HWIC with a Cisco 1841 or a Cisco 2800 Series integrated services router also provides an ideal replacement solution for Cisco 2505, Cisco 2507, or Cisco 2516 users whose requirements have expanded beyond the existing Cisco 2500 router or hub capabilities.

Figure 3 shows an example of a typical converged deployment for a small-to-large enterprise branch office with IP phones.

Figure 3. Typical Converged Deployment for a Small-to-Large Enterprise Branch Office with IP Phones

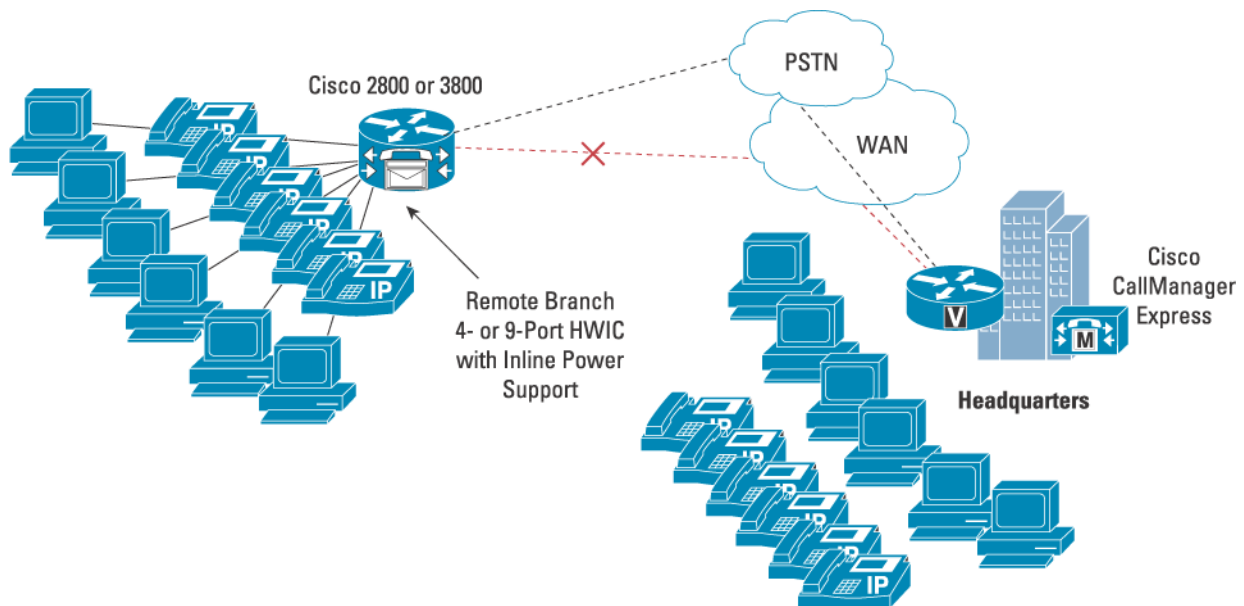

Converged IP Communications in a Small-to-Large Enterprise Branch Office with Data Devices and IP Phones

The 4- or 9-port Cisco EtherSwitch HWICs when combined with analog or digital voice modules for the Cisco 2800 and Cisco 3800 series routers provide a small-to-large enterprise branch office infrastructure for IP telephony deployments. This solution can be combined with Cisco CallManager Express IP Telephony or the Cisco IOS Software Survivable Remote Site Telephony (SRST) solution. SRST runs on the local branch office router, allowing it to automatically detect a failure in the network, and initiates a process to intelligently autoconfigure the router to provide call-processing backup redundancy for the IP phones in that office. In the case of a Cisco CallManager Express deployment, call-processing features are offered on the branch router without a centralized call manager.

The Cisco EtherSwitch HWIC with the optional internal chassis provides IP phone power and phone discovery for IP phones. In addition, the Cisco EtherSwitch HWIC supports separate VLAN configuration for IP phones. The auxiliary VLAN feature allows network administrators to segment phones into separate logical networks, even though the data and voice infrastructures are physically the same. The phone discovery feature allows the Cisco 4- and 9-port EtherSwitch HWICs (product numbers HWIC-4ESW-POE or HWIC-D-9ESW-POE) to automatically detect the presence of an IP phone and supply inline power.

For more information about the voice features for the Cisco 2800 and Cisco 3800 series routers, visit:

Cisco 2800 Series: <http://www.cisco.com/go/2800>

Cisco 3800 Series: <http://www.cisco.com/go/3800>

FEATURES AND BENEFITS

Table 4 gives the architecture, features, and benefits of the Cisco 4- and 9-port HWICs.

Table 4. Architecture, Features, and Benefits of 4- and 9-Port Cisco EtherSwitch HWICs

Feature	Benefit
4 or 9 10BASE-T/100BASE-TX Ports	These ports deliver up to 200 Mbps of aggregate bandwidth (full duplex) for forwarding Layer 2 traffic on each port.
Autosensing, Autonegotiation, and Auto-MDIX (Automatic Media-Dependant Interface Crossed Over)	<ul style="list-style-type: none">• The Autosensing feature allows the switch to detect the speed of the attached device and automatically configure the port for 10- or 100-Mbps operation.• The Autonegotiation feature allows the switch to automatically select half- or full-duplex transmission mode to optimize bandwidth on all the ports of the HWIC• The Auto-MDIX feature allows the switch to automatically detect cable type (straight through vs. crossover) between the attached Ethernet device and switch line pairs.
Integrated Switching	Integrated switching provides fewer points of management for remote and small branch offices.
802.1P QoS (Traffic Prioritization)	This feature provides support for QoS based on the IEEE class of service (CoS) and port-based prioritization, allowing the switch to change the CoS settings of tagged packets on a per-port basis.
802.1Q Trunking	This feature allows the setup of separate VLANs with tagged and untagged framing; trunking is used to save ports when creating a link between two devices implementing VLANs; VLANs allow segmentation of the LAN.
802.1D Spanning Tree Protocol	This Layer 2 link-management protocol provides path redundancy while preventing undesirable loops in the network; it simplifies network configuration and improves fault tolerance.
Voice VLAN (VVLAN)	VVLANS help enable Cisco IP phones to place voice and data in their own separate VLANs. The HWIC switch port is manually configured as a trunk port to support voice and data VLANs on the same port. The switch then uses Cisco Discovery to dynamically configure the Cisco IP phones.
802.1x Authentication	This client-server-based access control and authentication protocol restricts unauthorized devices from connecting to a LAN through publicly accessible ports.

Feature	Benefit
PoE (Option)	Cisco EtherSwitch technology with the appropriate inline power module and internal power supply can power Cisco IP phones and wireless access points. Support is provided for both IEEE 802.3af PoE and Cisco prestandard inline powered devices. The ninth port of the 9-port HWIC (part number HWIC-D-9ESW-POE) cannot be used for PoE applications. The PoE option is not available on the Cisco 1841 router.
Multicast Management Support	This feature offers Internet Group Management Protocol (IGMP) snooping in hardware for management support.
Simple Network Management Protocol (SNMP) Management	SNMP allows management of the MIB through a MIB browser.
Cisco IOS Software Command-Line Interface (CLI)	This feature provides configuration through the Cisco IOS Software CLI and provides a common user interface for all the router functions.
CiscoWorks Support	<ul style="list-style-type: none"> • CiscoWorks network management software helps enable manageability on a per-port and per-switch basis, providing a common management interface for Cisco routers, switches, and hubs. • SNMPv1, v2, and v3 (noncryptographic) and Telnet interface support delivers comprehensive in-band management, and a CLI management console provides detailed out-of-band management. • Cisco Discovery Protocol Versions 1 and 2 help enable a CiscoWorks network management station to automatically discover the switch in a network topology. • Support is provided by the CiscoWorks LAN Management Solution.
Cisco Discovery Protocol Versions 1 and 2	This protocol enables a CiscoWorks network management station to automatically discover the switch in a network topology.
VLAN Trunking Protocols (Client, Server, and Transparent Modes)	The Cisco Virtual Lan Trunking Protocol (VTP) supports dynamic VLAN configuration across Cisco switches.
Cisco Secure Router and Device Manager (SDM)-Based Configuration and Device Management	<ul style="list-style-type: none"> • This feature simplifies initial configuration of a switch through a Web browser, eliminating the need for more complex terminal emulation programs and CLI knowledge. • Cisco SDM reduces the cost of deployment by helping less-skilled personnel set up switches quickly and simply.
Status LEDs	Two LEDs per port provide convenient visual indication of the switch port and inline power status.

SUMMARY AND CONCLUSION

The 4- and 9-port Cisco EtherSwitch HWICs (part numbers HWIC-4ESW and HWIC-D-9ESW) are managed 10/100BASE-T Layer 2 switches in a HWIC form factor for the Cisco 1800 (modular), Cisco 2800, and Cisco 3800 series integrated services routers. The 4-port HWIC comes in a single-wide form factor, and the 9-port HWIC in a double-wide form factor. The switch supports the IEEE 802.1D Spanning Tree Protocol and can be used to connect up to 4 or 9 LANs with up to 15 IEEE 802.1Q-based VLANs (802.1Q). Note: Both HWICs—the 4- and 9-port HWICs—support up to 15 VLANs. They also can be optionally configured to provide 4 or 8 ports of inline power for 802.3af- or Cisco PoE-capable devices. The PoE support is not available on the Cisco 1841 router.

SPECIFICATIONS

Table 5 gives product specifications of the 4- and 9-port Cisco EtherSwitch HWICs.

Table 5. Product Specifications of 4- and 9-Port Cisco EtherSwitch HWICs (HWIC-4ESW, HWIC-4ESW-POE, HWIC-D9ESW, and HWIC-D-9ESW-POE)

Feature	Description
Target Applications	Data, voice, and video

Feature	Description		
Supported Router Platforms	<ul style="list-style-type: none"> • Cisco 1800 (modular), Cisco 2800, and Cisco 3800 series integrated services routers: • Cisco 1841 (supports HWIC-4ESW only; no PoE support) • Cisco 2801 • Cisco 2811 • Cisco 2821 • Cisco 2851 • Cisco 3825 • Cisco 3845 		
Form Factor	<ul style="list-style-type: none"> • HWIC-4ESW = Single-wide HWIC form factor • HWIC-D-9ESW = Double-wide HWIC form factor 		
Dimensions (W x D x H)	<ul style="list-style-type: none"> • HWIC-4ESW = 3.08 x 4.74 x 0.76 in. • HWIC-D-9ESW = 6.20 x 4.74 x 0.76 in. 		
Weight	<ul style="list-style-type: none"> • HWIC-4ESW = 79 grams (0.17 lb) • HWIC-4ESW-POE = 108 grams (0.24 lb) • HWIC-D-9ESW = 149 grams (0.33 lb) • HWIC-D-9ESW-POE = 196 grams (0.43 lb) 		
Standards			
IEEE Protocols	<ul style="list-style-type: none"> • Ethernet: IEEE 802.3, 10BASE-T • Fast Ethernet: IEEE 802.3u, 100BASE-TX • IEEE 802.1d Spanning Tree Protocol • IEEE 802.1p CoS for Traffic Prioritization • IEEE 802.1q VLAN • IEEE 802.1x Security • IEEE 802.3x Full Duplex and Flow Control • IEEE 802.3af Power over Ethernet Standard 		
RFC	RFC 2284, PPP Extensible Authentication Protocol (EAP)		
MIBs	<table border="0"> <tr> <td> <ul style="list-style-type: none"> • RFC 1213 • IF MIB • RFC 2037 ENTITY MIB • CISCO-CDP-MIB • CISCO-IMAGE-MIB • CISCO-FLASH-MIB • OLD-CISCO-CHASSIS-MIB • CISCO-VTP-MIB • CISCO-HSRP-MIB • OLD-CISCO-TS-MIB • CISCO-ENTITY-ASSET-MIB • CISCO-ENTITY-FRU-CONTROL-MIB • BRIDGE MIB (RFC 1493) </td> <td> <ul style="list-style-type: none"> • CISCO-VLAN-MEMBERSHIP-MIB • CISCO-VLAN-IFINDEX-RELATIONSHIP-MIB • RMON1-MIB • PIM-MIB • CISCO-STP-EXTENSIONS-MIB • OSPF MIB (RFC 1253) • IPMROUTE-MIB • CISCO-MEMORY-POOL-MIB • ETHER-LIKE-MIB (RFC 1643) • CISCO-ENTITY-FRU-CONTROL-MIB.my • CISCO-RTTMON-MIB • CISCO-PROCESS-MIB • CISCO-COPS-CLIENT-MIB </td> </tr> </table> <p>To obtain lists of supported MIBs by platform and Cisco IOS Software release, and to download MIB modules, go to the Cisco MIB Website on Cisco.com at the following URL:</p> <p>http://www.cisco.com/public/sw-center/netmgmt/cmtk/mibs.shtml</p>	<ul style="list-style-type: none"> • RFC 1213 • IF MIB • RFC 2037 ENTITY MIB • CISCO-CDP-MIB • CISCO-IMAGE-MIB • CISCO-FLASH-MIB • OLD-CISCO-CHASSIS-MIB • CISCO-VTP-MIB • CISCO-HSRP-MIB • OLD-CISCO-TS-MIB • CISCO-ENTITY-ASSET-MIB • CISCO-ENTITY-FRU-CONTROL-MIB • BRIDGE MIB (RFC 1493) 	<ul style="list-style-type: none"> • CISCO-VLAN-MEMBERSHIP-MIB • CISCO-VLAN-IFINDEX-RELATIONSHIP-MIB • RMON1-MIB • PIM-MIB • CISCO-STP-EXTENSIONS-MIB • OSPF MIB (RFC 1253) • IPMROUTE-MIB • CISCO-MEMORY-POOL-MIB • ETHER-LIKE-MIB (RFC 1643) • CISCO-ENTITY-FRU-CONTROL-MIB.my • CISCO-RTTMON-MIB • CISCO-PROCESS-MIB • CISCO-COPS-CLIENT-MIB
<ul style="list-style-type: none"> • RFC 1213 • IF MIB • RFC 2037 ENTITY MIB • CISCO-CDP-MIB • CISCO-IMAGE-MIB • CISCO-FLASH-MIB • OLD-CISCO-CHASSIS-MIB • CISCO-VTP-MIB • CISCO-HSRP-MIB • OLD-CISCO-TS-MIB • CISCO-ENTITY-ASSET-MIB • CISCO-ENTITY-FRU-CONTROL-MIB • BRIDGE MIB (RFC 1493) 	<ul style="list-style-type: none"> • CISCO-VLAN-MEMBERSHIP-MIB • CISCO-VLAN-IFINDEX-RELATIONSHIP-MIB • RMON1-MIB • PIM-MIB • CISCO-STP-EXTENSIONS-MIB • OSPF MIB (RFC 1253) • IPMROUTE-MIB • CISCO-MEMORY-POOL-MIB • ETHER-LIKE-MIB (RFC 1643) • CISCO-ENTITY-FRU-CONTROL-MIB.my • CISCO-RTTMON-MIB • CISCO-PROCESS-MIB • CISCO-COPS-CLIENT-MIB 		

Feature	Description
Manageability	<ul style="list-style-type: none"> • SNMP and Telnet interface support delivers comprehensive in-band management, and a CLI management console provides detailed out-of-band management. • An embedded Remote Monitoring (RMON) software agent supports four RMON groups (history, statistics, alarms, and events) for enhanced traffic management, monitoring, and analysis. • A Switched Port Analyzer (SPAN) port can mirror traffic from one or many ports to another port for monitoring all nine RMON groups with an RMON probe or network analyzer. • Trivial File Transfer Protocol (TFTP) reduces the cost of administering software upgrades by downloading from a centralized location. • Network Timing Protocol (NTP) provides an accurate and consistent time stamp to all switches within the intranet. • Two LEDs per port provide convenient visual indication of the port link and inline power status. • Crash information support helps enable a switch to generate a crash file for improved troubleshooting. • Show-interface capabilities provide information about the configuration capabilities of any interface. • The Response Time Monitoring (RTTMON) MIB allows users to monitor network performance between the HWIC switch and a remote device.
Connectors and Cabling	<ul style="list-style-type: none"> • 10BASE-T ports: RJ-45 connectors, two-pair Category 3, 4, or 5 unshielded twisted-pair (UTP) cabling • 100BASE-TX ports: RJ-45 connectors; two-pair Category 5 UTP cabling
Indicators	<ul style="list-style-type: none"> • Link status LED: One LED per port for indicating link status • Inline power LED: One LED per port system for inline power status indication
Power Requirements	
Internal Power Supply	Optional PoE system power supply available for all Cisco 2800 and Cisco 3800 series routers
Redundant Power Supply	For the Cisco 3845 router only
DC Power Support	DC system power input available on the Cisco 2811, Cisco 2821, Cisco 2851, Cisco 3825, and Cisco 3845 routers; PoE option not available with DC system power input
Software Support	Minimum Cisco IOS Software Release 12.3(8)T
Environmental	
Operating Temperature	32 to 104°F (0 to 40°C)
Operating Humidity	10 to 85% noncondensing operating; 5 to 95% noncondensing, nonoperating
Nonoperating Temperature	-4 to 149°F (-20 to 65°C)
Operating Altitude	(derate 1.5°C per 1000 feet)
Regulatory Compliance, Safety, EMC	<p>When installed in a Cisco 1841, Cisco 2800, or Cisco 3800 router, the Cisco EtherSwitch HWIC meets the standards (regulatory compliance, safety, EMC) of the router itself. Refer to the data sheets for the Cisco 1841, Cisco 2800, and Cisco 3800 series routers for more details:</p> <p>http://www.cisco.com/go/1800</p> <p>http://www.cisco.com/go/2800</p> <p>http://www.cisco.com/go/3800</p>

ORDERING INFORMATION

To place an order, visit the [Cisco Ordering Home Page](#).

For more information about the Cisco 1800 Series, including Cisco 1700 Series to Cisco 1800 Series migration aids, the Cisco 2800 Series, and the Cisco 3800 Series, visit:

<http://www.cisco.com/go/1800>

<http://www.cisco.com/go/2800>

<http://www.cisco.com/go/3800>

Table 6 provides ordering information for the 4- and 9-port Cisco EtherSwitch HWICs.

Table 6. Ordering Information for 4- and 9-Port Cisco EtherSwitch HWICs (part numbers HWIC- 4ESW and HWIC-D-9ESW)

Product Number	Product Description
Ethernet HWICs	
HWIC-4ESW	4-port 10/100 Ethernet switch
HWIC-4ESW=	4-port 10/100 Ethernet switch, spare
HWIC-4ESW-POE	4-port 10/100 Ethernet switch with 4-port inline power daughter card
HWIC-4ESW-POE=	4-port 10/100 Ethernet switch with 4-port inline power daughter card, spare
HWIC-D-9ESW	9-port 10/100 Ethernet switch
HWIC-D-9ESW=	9-port 10/100 Ethernet switch, spare
HWIC-D-9ESW-POE	9-port 10/100 Ethernet switch with 8-port inline power daughter card
HWIC-D-9ESW-POE=	9-port 10/100 Ethernet switch with 8-port inline power daughter card, spare
Daughter Card Modules for Inline Power Support	
ILPM-4=	4-port inline power module for PoE applications, spare
ILPM-8=	8-port Inline power module for PoE applications, spare
Cisco 2800 and Cisco 3800 Routers with Inline Power Supply	
CISCO2801-AC-IP	Cisco 2801 router with inline power, 2 Fast Ethernet ports, 4 slots, IP BASE, 64F/128D
CISCO2811-AC-IP	Cisco 2811 with AC+PoE, 2 Fast Ethernet ports , 4 HWICs, 2 packet voice DSP modules (PVDMs), 1 enhanced network module [(NME), 2 advanced integration modules (AIMs), IP BASE, 64F/256D
CISCO2821-AC-IP	Cisco 2821 with AC+PoE, 2 Gigabit Ethernet ports, 4 HWICs, 3 PVDMs, 1 NME-X, 2 AIMs, IP BASE, 64F/256D
CISCO2851-AC-IP	Cisco 2851 with AC+PoE, 2 Gigabit Ethernet ports, 4 HWICs, 3 PVDMs, 1 NME-XD, 2 AIMs, IP BASE, 64F/256D
CISCO3825-AC-IP	2 Gigabit Ethernet router with 1 Small Form-Factor Pluggable (SFP), 2 NME-XHDs, 4 HWICs, IP BASE, power supply
CISCO3845-AC-IP	2 Gigabit Ethernet router with 1 SFP, 4 NME-XHDs, 4 HWICs, IP BASE, power supply
Inline Power Supply	
PWR-2801-AC-IP	Cisco 2801 AC inline power supply
PWR-2801-AC-IP=	Cisco 2801 AC inline power supply, spare
PWR-2821-51-AC-IP=	Cisco 2821 and Cisco 2851 AC-IP power supply, spare
PWR-3825-AC-IP=	Cisco 3825 AC-IP power supply, spare
PWR-3845-AC-IP=	Cisco 3845 AC-IP power supply, spare

Also, check with your Cisco representative regarding the Cisco 1800 (modular), Cisco 2800, and Cisco 3800 series bundle offerings for security, voice, DSL, and other solutions.

CISCO IOS SOFTWARE SUPPORT

The Cisco EtherSwitch HWICs are supported in all Cisco IOS Software feature sets. Table 7 lists the first Cisco IOS Software release the 4- and 9-port HWICs are supported on for the respective routing platforms.

Table 7. Minimum Supported Cisco IOS Software Release

Integrated Services Router Version	Minimum Cisco IOS Software Release
Cisco 1800 (Modular) Series	12.3(8)T (fourth release of Cisco IOS Software Release 12.3T)
Cisco 2800 Series	12.3(8)T (fourth release of Cisco IOS Software Release 12.3T)
Cisco 3800 Series	12.3(11)T (fifth release of Cisco IOS Software Release 12.3T)

SERVICE AND SUPPORT

Leading-edge technology deserves leading-edge support. Cisco Systems® offers a wide range of services programs to accelerate customer success. These innovative services programs are delivered through a unique combination of people, processes, tools, and partners, resulting in high levels of customer satisfaction. Cisco services help you protect your network investment, optimize network operations, and prepare your network for new applications to extend network intelligence and the power of your business.

Cisco SMARTnet® technical support for the 4- and 9-port Cisco EtherSwitch HWICs (part numbers HWIC-4ESW and HWIC-D-9ESW) is available on a one-time or annual contract basis. Support options range from help-desk assistance to proactive, onsite consultation.

All support contracts include:

- Major Cisco IOS Software updates in protocol, security, bandwidth, and feature improvements
- Full access rights to Cisco.com technical libraries for technical assistance, electronic commerce, and product information
- Twenty-four-hour access to the industry's largest dedicated technical support staff

For more information about Cisco services, refer to [Cisco Technical Support Services](#) or [Cisco Advanced Services](#).

FOR MORE INFORMATION

For more information about the Cisco 1800 Series Integrated Services Router, visit <http://www.cisco.com/go/1800> or contact your local Cisco account representative.

For More Information about Cisco products, contact:

United States and Canada: 800 553-NETS (6387)

Europe: 32 2 778 4242

Australia: 612 9935 4107

Other: 408 526-7209

Web: <http://www.cisco.com>

**Corporate Headquarters**

Cisco Systems, Inc.
170 West Tasman Drive
San Jose, CA 95134-1706
USA
www.cisco.com
Tel: 408 526-4000
800 553-NETS (6387)
Fax: 408 526-4100

European Headquarters

Cisco Systems International BV
Haarlerbergpark
Haarlerbergweg 13-19
1101 CH Amsterdam
The Netherlands
www-europe.cisco.com
Tel: 31 0 20 357 1000
Fax: 31 0 20 357 1100

Americas Headquarters

Cisco Systems, Inc.
170 West Tasman Drive
San Jose, CA 95134-1706
USA
www.cisco.com
Tel: 408 526-7660
Fax: 408 527-0883

Asia Pacific Headquarters

Cisco Systems, Inc.
168 Robinson Road
#28-01 Capital Tower
Singapore 068912
www.cisco.com
Tel: +65 6317 7777
Fax: +65 6317 7799

Cisco Systems has more than 200 offices in the following countries and regions. Addresses, phone numbers, and fax numbers are listed on **the Cisco Website at www.cisco.com/go/offices.**

Argentina • Australia • Austria • Belgium • Brazil • Bulgaria • Canada • Chile • China PRC • Colombia • Costa Rica • Croatia • Cyprus
Czech Republic • Denmark • Dubai, UAE • Finland • France • Germany • Greece • Hong Kong SAR • Hungary • India • Indonesia • Ireland • Israel
Italy • Japan • Korea • Luxembourg • Malaysia • Mexico • The Netherlands • New Zealand • Norway • Peru • Philippines • Poland • Portugal
Puerto Rico • Romania • Russia • Saudi Arabia • Scotland • Singapore • Slovakia • Slovenia • South Africa • Spain • Sweden • Switzerland • Taiwan
Thailand • Turkey • Ukraine • United Kingdom • United States • Venezuela • Vietnam • Zimbabwe

Copyright © 2005 Cisco Systems, Inc. All rights reserved. CCSP, CCVP, the Cisco Square Bridge logo, Follow Me Browsing, and StackWise are trademarks of Cisco Systems, Inc.; Changing the Way We Work, Live, Play, and Learn, and iQuick Study are service marks of Cisco Systems, Inc.; and Access Registrar, Aironet, ASIST, BPX, Catalyst, CCDA, CCDP, CCIE, CCIP, CCNA, CCNP, Cisco, the Cisco Certified Internetwork Expert logo, Cisco IOS, Cisco Press, Cisco Systems, Cisco Systems Capital, the Cisco Systems logo, Cisco Unity, Empowering the Internet Generation, Enterprise/Solver, EtherChannel, EtherFast, EtherSwitch, Fast Step, FormShare, GigaDrive, GigaStack, HomeLink, Internet Quotient, IOS, IP/TV, iQ Expertise, the iQ logo, iQ Net Readiness Scorecard, LightStream, Linksys, MeetingPlace, MGX, the Networkers logo, Networking Academy, Network Registrar, Packet, PIX, Post-Routing, Pre-Routing, ProConnect, RateMUX, ScriptShare, SlideCast, SMARTnet, StrataView Plus, TeleRouter, The Fastest Way to Increase Your Internet Quotient, and TransPath are registered trademarks of Cisco Systems, Inc. and/or its affiliates in the United States and certain other countries.

All other trademarks mentioned in this document or Website are the property of their respective owners. The use of the word partner does not imply a partnership relationship between Cisco and any other company. (0502R) 205290.BB_ETMG_CC_6.05

