

Cisco IAD2430 Business Class Integrated Access Device

The Cisco® IAD2430 is the next-generation integrated voice and data services platform for service providers, building on the industry-leading IAD2420. The Cisco IAD2430 offers a major leap forward in price performance and enhanced software functions, such as Cisco CallManager Express) and rich Media Gateway Control Protocol (MGCP) gateway services, to cost-effectively accelerate the migration from time-division multiplexing (TDM) to voice over IP (VoIP). The Cisco IAD2430 builds on the maturity of the Cisco IAD2420 software by providing denser interfaces (up to 24FXS and up to 2 data T1s), an encryption co-processor, and DC battery backup input while maintaining a 1-rack-unit (RU) form factor for space-saving service provider managed services deployments.

The Cisco IAD2430 offers the best-in-class integration of data and toll-quality analog or digital voice services for a customer-premises solution. Designed to bridge the current and emerging multiservice needs of competitive local exchange carriers (CLECs), incumbent local exchange carriers (ILECs), and interexchange carriers (IXCs), the Cisco IAD2430 operates in both Class 5 switch-access and Class 5 switch-bypass architectures. Robust data and rich voice services in an interoperable system architecture allow service providers to offer new revenue-generating services.

Powered by Cisco IOS® Software, driven by a Reduced Instruction Set Computer (RISC) processor and high-performance digital signal processors (DSPs), the Cisco IAD2430 supports VoIP, with proven quality-of-service (QoS) tools, multiple call-control protocols (such as Session Initiation Protocol [SIP], MGCP, and H.323), and diverse VoIP codecs. In addition to industry-leading voice features, the Cisco IAD2430 uses Cisco IOS Software for data features such as IP routing, on-board encryption co-processor (Triple Data Encryption Standard [3DES]), Dynamic Host Configuration Protocol (DHCP), Network Address Translation (NAT), and network security. The choice of high-density analog and digital voice interfaces over a wide range of broadband technologies furthers the appeal of the Cisco IAD2430 to a broad spectrum of service providers.

Figure 1. The Cisco IAD2430 Series Devices



The Cisco IAD2430 builds on the Cisco IAD2420's patented Simple Network-enabled Auto Provisioning (SNAP) technology, a next-generation auto-installation mechanism designed for faster service turn-up, configuration, and remote updates. When used with Cisco Configuration Express, service providers can order, preconfigure, and ship the Cisco IAD2430 directly to end customers, reducing the costs of warehousing, shipping, and manual intervention.

PRIMARY APPLICATIONS

The Cisco IAD2400 Family Series has set the stage for migration from traditional to new architectures, by allowing service providers to deliver toll-quality voice and data services over circuit- or packet-switched networks. With the Cisco IAD2430, changes in the core service provider's network are transparent to end users.

Figures 2 and 3 show the Cisco IAD2430 network architectures. Service providers can start by offering simple TDM-based voice services as depicted in Figure 2. As end-customer needs grow and service providers deploy more packet-based technologies in their network cores, customers can gradually be migrated to more cost-effective service offerings based on packetized voice as shown in Figure 3. The Cisco IAD2430 derives local voice services from either TDM-based Class 5 switches or from call agents (soft switches).

Figure 2. Cisco IAD2430 in a Data and GR.303-Based Voice (TDM) Architecture

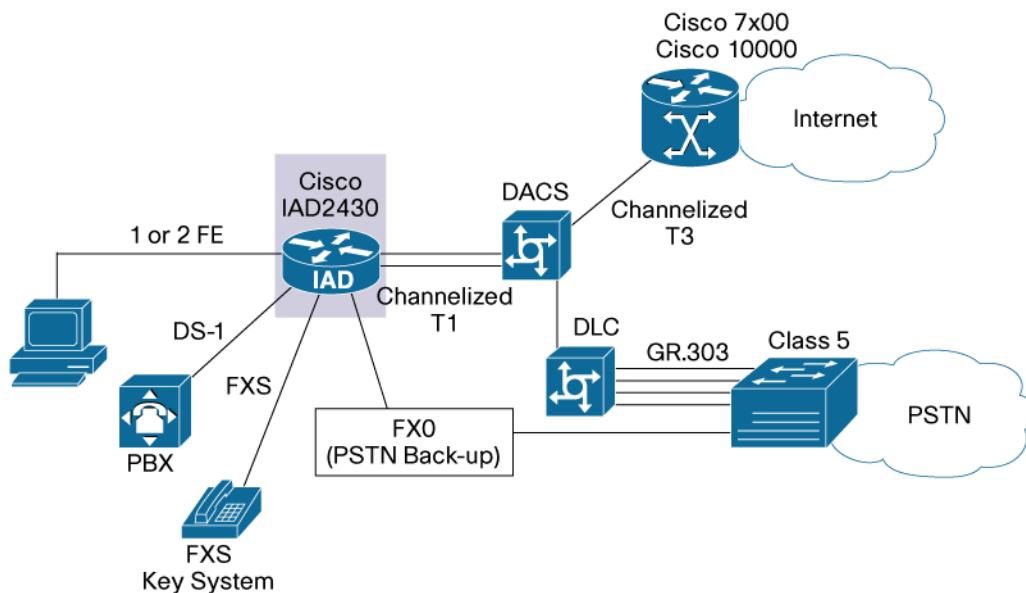
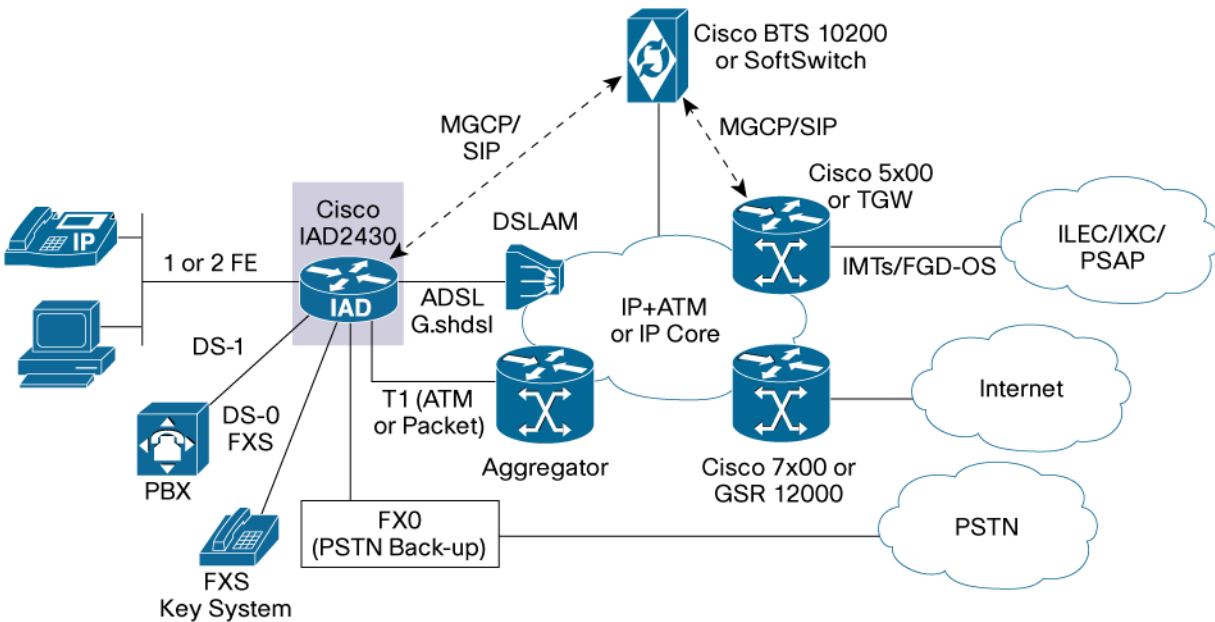

Figure 3. Cisco IAD2430 in Data and Call Agent-Based Voice (VoIP) Architecture



PRIMARY FEATURES AND BENEFITS TO SERVICE PROVIDERS

Transparent Service Migration

The Cisco IAD2430 enables service providers to transparently migrate end customers from TDM-based GR.303 voice service to call agent-based packet voice services without the need for a truck roll to the end-customer site. The provider can choose H.323, MGCP, and SIP for VoIP protocols, based on the services that need to be delivered.

Flexibility

The Cisco IAD2400 Series is the first in the industry to offer TDM and VoIP with the rich VoIP signaling protocol support. Combined with the option for call agent- and GR.303-based network designs, the Cisco IAD2400 Series offers unrivaled flexibility in the design of next-generation multiservice networks.

Functional Intelligence

Regardless of the wide-area technology, next-generation service providers can use the SNAP technology to remotely install and configure the Cisco IAD2400 Series devices. When used with the popular Cisco Configuration Express tool, the auto-installation technology offers true plug-and-play installation. In addition, the Cisco IAD2400 Series is based on Cisco IOS Software and provides the same IP features that power more than 80 percent of the Internet infrastructure. Cisco IOS® Software delivers rich data services, which allows service providers to gain additional data revenues, in addition to proven industry-tested voice features.

Operational Efficiencies

The new Cisco IAD2430 Series increases operational efficiencies by reducing or eliminating complete hardware upgrades, warehousing, truck rolls, and highly skilled technician involvement. When deployed with other Cisco equipment and Cisco IOS Software, service providers can cost-effectively extend training, administration, and maintenance activities across the entire network.

End-to-End Solution

Compatibility with a wide range of industry-leading digital subscriber line access multiplexers (DSLAMs) and voice gateways, combined with the world-class data features of Cisco IOS Software, enables service providers to deploy a highly efficient and scalable end-to-end multiservice network. The Cisco IAD2430 is an integral part of Cisco packet voice solutions.

PRIMARY BENEFITS TO END USERS

Robust Voice Quality

The Cisco experience in providing toll-quality packet-voice service helps ensure that the Cisco IAD2430 provides the clear, robust voice quality end users have come to expect from telephony services.

Reliability

Cisco products are renowned for their exceptional reliability earned through years of proven industry service. The Cisco IAD2430 extends the same reliability standards to managed service environments to provide end users with the highest level of dependability.

Service Flexibility

Today's rapidly changing business environment leads to constant change in network requirements of small and medium-sized businesses (SMBs). The Cisco IAD2430 facilitates such changes and allows service providers to add or remove service offerings remotely based on end-user needs.

Table 1. Feature and Benefit Summary

| Feature | Benefit |
|---|---|
| Works with Both Class 5 Switch-Access and Class 5 Switch-Alternative Architectures | <ul style="list-style-type: none">• Provides compatibility with current and emerging voice architectures• Allows transparent service migration• Works throughout the service provider network |
| Enables TDM Voice, VoIP, and VoIP over ATM | <ul style="list-style-type: none">• Gives freedom of choice to service providers and end users• Allows service providers to meet the needs of a diverse customer base |
| Delivers SNAP Technology and Cisco Configuration Express Tools | <ul style="list-style-type: none">• Allows remote installation and configuration with minimal technician involvement• Reduces or eliminates truck rolls and associated costs• Requires technicians with less training• Allows immediate service additions and deletions to be performed remotely• Speeds customer service and support• Allows direct shipment to end-user site, thereby eliminating warehousing of inventory and manual handling |
| Provides 3DES Co-Processor Encryption Engine | <ul style="list-style-type: none">• Enables fast and strong encryption for security• Provides peace of mind for SMB customers |
| Provides Interoperability with a Wide Variety of Vendors | <ul style="list-style-type: none">• Allows service providers to design and configure networks that fit specific needs• Eliminates compatibility concerns with major vendors |
| Integrates with the End-to-End Cisco Solution | <ul style="list-style-type: none">• Reduces training and maintenance costs• Works with the other components of Cisco packet voice solutions |
| Delivers Toll-Quality Voice Service | <ul style="list-style-type: none">• Provides the level of voice quality end users have come to expect |

| Feature | Benefit |
|-----------------------------|---|
| Offers Proven Reliability | <ul style="list-style-type: none"> • Provides trouble-free operation to end users • Reflects favorably on the service provider offering quality |
| Enables Service Flexibility | <ul style="list-style-type: none"> • Allows service changes to be performed instantly and remotely |

TECHNICAL SPECIFICATIONS

WAN Options

- One or two T1/E1 (Point-to-Point Protocol [PPP], High-Level Data Link Control [HDLC], or Frame Relay) with integrated channel service unit/digital service unit (CSU/DSU) (RJ-48 connector)
- One or two Fast Ethernet (10/100BASE-T) ports for Ethernet access
- One voice WAN interface card (VWIC) slot for:
 - Broadband interfaces
 - ADSL (WIC1-ADSL) or G.SHDSL (WIC1-SHDSL) for DSL uplink
 - WAN: WIC-1DSU-T1, VWIC-2MFT-T1, VWIC-2MFT-E1
 - Voice interfaces—VIC2-4FXO, VIC2-2FXO, VIC2-2FXS, VIC-4FXS/DID, VIC2-2BRI-NT/TE
 - Serial interfaces—WIC-2T, WIC-1T

Voice

- **Analog:** 8 FXS/16 FXS/24 FXS ports (RJ-21 connector)
- **Digital:** One T1-PBX (channel associated signaling [CAS], Primary Rate Interface [PRI]) port
- **Bearer:** TDM voice, VoIP (Real-Time Transport Protocol [RFC1889] [RTP], cRTP)
- **VoIP properties:** RTP, cRTP, echo cancellation, silence suppression/comfort noise, modem passthrough, Cisco fax relay, T.38 fax relay
- **Call control:** MGCP 0.1, MGCP 1.0, H.323, SIP
- **DSPs:** CELP (G.729a), ADPCM (G.726 (32), G.726(16)), PCM (G.711uLaw, G.711aLaw)
- **Interface type:** Loop start, ground start
- **RENs:** 5 REN per port, 12 REN per system
- **Simultaneous voice calls (digital/analog):** 24/24

CLASS Features for xGCP

- Call waiting, cancel call waiting
- Caller ID with name and number
- Caller ID blocking
- Caller ID with name/number and call waiting
- Call forwarding: no answer/busy/variable
- Call forwarding: remote access
- Call transfer
- Three-way calling
- Message waiting indicator/tone (stutter)
- Call return (*69)
- Repeat dialing, busy call return (*66)
- Call blocking with toll restriction
- Call trace
- Call screening (*60)

- Distinctive-ring service
- Off-hook warning tone
- Selective/anonymous call rejection

Data

- Up to two 10/100BaseTX port (RJ-45 connector)
- **WAN:** PPP, HDLC, MLPPP, Frame Relay
- **Frame relay:** FRF.5/FRF.8, FRF.12
- **QoS (IP):** LLQ, Differentiated Service Code Points (DSCP), IP precedence, CAR
- **Routing:** RIP v1/v2, OSPF, static
- **Security:** ACLs, multiple levels of passwords
- **Encryption:** 3DES co-processor
- **Data services:** VPN/firewall (feature license)
- **Other:** NAT/PAT, DHCP server/client/relay, IEEE 802.1d

System

- **Processor:** RISC processor
- **Memory (default):** 128/64MB SDRAM
- **Internal flash (default):** 32/64 MB
- **Compact flash:** One slot Type II
- **Modularity:** One VWIC slot
- **Encryption:** On-board 3DES co-processor
- **Console/auxiliary (max):** Up to 119.2kbps per port

Interoperability

- **Trunking gateway:** Cisco 3660, Cisco AS5000 Series, MGX 8800 Series
- **Call agents:** Cisco BTS 10200, Broadsoft, Vocaldata, Nuera, General Bandwidth

Management

- SNAP auto-installation technology
- Cisco CNS 1.5
- CiscoView 2000
- IE2100

Power

- **AC input voltage:** 100 to 240 VAC
- **AC input current (max):** 1 Amp
- **DC input voltage:** 12 V
- **Frequency:** 50 to 60 Hz
- **Power dissipation (max):** 70W
 - Cisco IAD2430-24FXS—60W
 - Cisco IAD2431-8FXS—50W
 - Cisco IAD2431-16FXS—60W
 - Cisco IAD2431-1T1E1—35W
 - Cisco IAD2432-24FXS—70W

Physical

- **Width:** 17.50 inches (444.5 mm)
- **Height:** 1.75 inches (44.4 mm) (add 0.17 inch for optional rubber feet)
- **Depth:** 13.5 inches (342.9 mm)
- **Weight (max):** 11 lb (4.106 kg)
- Rack or wall mountable

Table 2. Voice Port

| Category | Specification |
|---|---|
| Tip/Ring Interfaces for each FXS Port (SLIC) | |
| Ring Voltage | <ul style="list-style-type: none">• 50V if no DC offset |
| Ring Frequency | <ul style="list-style-type: none">• 20, 25, 30, 50 Hz |
| Ring Waveform | <ul style="list-style-type: none">• Sine wave if no DC offset• 20 and 24 V dc offset will be trapezoidal |
| Ring Load | <ul style="list-style-type: none">• 1400 ohm + 40µF (Up to three ports at once) |
| Ringer Equivalence Number (REN) | <ul style="list-style-type: none">• Up to 5 REN per FXS port, 12 REN per system |
| Loop Resistance | <ul style="list-style-type: none">• Up to 600 ohm (including the phone or terminal equipment) |
| On-Hook/Off-Hook Characteristics | |
| On-Hook Voltage (Tip/Ring) | <ul style="list-style-type: none">• -50 V (idle voltage high is set)• 20 V (idle voltage low is set) |
| Off-Hook Current | <ul style="list-style-type: none">• 25 mAmp (nominal) |
| RJ-11 FXS Port Terminating Impedance Option | <ul style="list-style-type: none">• 600 ohm complex, 600 ohm real, 900 ohm complex, 900 ohm real, complex1 and complex2 |

Environment

- **Operating temperature:** 32 to 104°F (0 to 40°C)
- **Non-operating temperature:** -40 to 158°F (-40 to 70°C)
- **Operating humidity:** 5 to 95% non-condensing
- **Noise level (max):** 55 dB @ 3 ft (0.914 meters)
- On premise only, restricted access area, permanent ground required, only to be serviced/installed by trained professionals. Table 3 shows NEBS type tests performed with the IAD2430 series.

Table 3. FXS Ports Power Cross Test Results

| NEBS Tests—Type 1/3—Power Cross—(Tip/Ring to Ground) | Result |
|--|--------|
| 50 V/0.33 A; 15 Min | Pass |
| 100 V/0.17 A; 15 Min | Pass |
| 200 V/1 A; 1 s Pulses, 60 Reps | Pass |

Certifications

- **Safety:** UL 60950 3rd Edition; IEC 60950 3rd Edition, AS/NZS 3260: 1993 with Amendments 1, 2, 3, and 4; TS001:1996 with Amendment 1
- **Emissions:** 47CFR15 Class A (FCC); CISPR22 Class A; EN55022 Class A; AS/NZS 3548 Class A (ACA); ICES003 Class A (Industry Canada); V-3 Class A (VCCI); CNS13438 Class A (BSMI); EN300386:2001 Class A
- **Immunity:** EN55024 and EN50082-1 (including EN 61000 4-2 Electrostatic Discharge; EN 61000 4-3 Radiated Susceptibility; EN 61000 4-4 Electrical Fast Transients; EN 61000 4-5 Power and Signal Line Surges); EN300386:2001
- Meets requirements of GR1089—Level 3 type 2/4; GR63
- This equipment complies with all the regulatory requirements for connection to the communications networks of each country in which it is sold.
../..../home/search.htm

Table 4. Cisco IAD2430 Series Model Numbers

| Part Number | Description |
|-------------------------|--|
| IAD2430-24FXS | Two 10/100BaseT ports with 24 FXS analog voice ports (no VWICs) |
| IAD2431-8FXS | One T1 WAN port, One 10/100BaseT port, One VWIC slot, with 8 FXS analog voice ports |
| IAD2431-16FXS | One T1 WAN port, Two 10/100BaseT ports, One VWIC slot, with 16 FXS analog voice ports |
| IAD2431-1T1E1 | One T1 WAN port, Two 10/100BaseT ports, One VWIC slot, with one T1/E1 digital voice port |
| IAD2432-24FXS | Two T1 WAN ports, Two 10/100BaseT ports, One VWIC slot, with 24 FXS analog voice ports |
| Feature Licenses | |
| FL-IAD2400-INT | Firewall and Network Address Translation (NAT) features for enhanced Internet access |
| FL-CCME-SMALL | Cisco CallManager Express for up to 24 phones |

**Corporate Headquarters**

Cisco Systems, Inc.
170 West Tasman Drive
San Jose, CA 95134-1706
USA
www.cisco.com
Tel: 408 526-4000
800 553-NETS (6387)
Fax: 408 526-4100

European Headquarters

Cisco Systems International BV
Haarlerbergpark
Haarlerbergweg 13-19
1101 CH Amsterdam
The Netherlands
www-europe.cisco.com
Tel: 31 0 20 357 1000
Fax: 31 0 20 357 1100

Americas Headquarters

Cisco Systems, Inc.
170 West Tasman Drive
San Jose, CA 95134-1706
USA
www.cisco.com
Tel: 408 526-7660
Fax: 408 527-0883

Asia Pacific Headquarters

Cisco Systems, Inc.
168 Robinson Road
#28-01 Capital Tower
Singapore 068912
www.cisco.com
Tel: +65 6317 7777
Fax: +65 6317 7799

Cisco Systems has more than 200 offices in the following countries and regions. Addresses, phone numbers, and fax numbers are listed on **the Cisco Website at www.cisco.com/go/offices.**

Argentina • Australia • Austria • Belgium • Brazil • Bulgaria • Canada • Chile • China PRC • Colombia • Costa Rica • Croatia • Cyprus
Czech Republic • Denmark • Dubai, UAE • Finland • France • Germany • Greece • Hong Kong SAR • Hungary • India • Indonesia • Ireland • Israel
Italy • Japan • Korea • Luxembourg • Malaysia • Mexico • The Netherlands • New Zealand • Norway • Peru • Philippines • Poland • Portugal
Puerto Rico • Romania • Russia • Saudi Arabia • Scotland • Singapore • Slovakia • Slovenia • South Africa • Spain • Sweden • Switzerland • Taiwan
Thailand • Turkey • Ukraine • United Kingdom • United States • Venezuela • Vietnam • Zimbabwe

Copyright © 2006 Cisco Systems, Inc. All rights reserved. CCSP, CCVP, the Cisco Square Bridge logo, Follow Me Browsing, and StackWise are trademarks of Cisco Systems, Inc.; Changing the Way We Work, Live, Play, and Learn, and iQuick Study are service marks of Cisco Systems, Inc.; and Access Registrar, Aironet, BPX, Catalyst, CCDA, CCDP, CCIE, CCIP, CCNA, CCNP, Cisco, the Cisco Certified Internetwork Expert logo, Cisco IOS, Cisco Press, Cisco Systems, Cisco Systems Capital, the Cisco Systems logo, Cisco Unity, Enterprise/Solver, EtherChannel, EtherFast, EtherSwitch, Fast Step, FormShare, GigaDrive, GigaStack, HomeLink, Internet Quotient, IOS, IP/TV, iQ Expertise, the iQ logo, iQ Net Readiness Scorecard, LightStream, Linksys, MeetingPlace, MGX, the Networkers logo, Networking Academy, Network Registrar, Packet, PIX, Post-Routing, Pre-Routing, ProConnect, RateMUX, ScriptShare, SlideCast, SMARTnet, The Fastest Way to Increase Your Internet Quotient, and TransPath are registered trademarks of Cisco Systems, Inc. and/or its affiliates in the United States and certain other countries.

All other trademarks mentioned in this document or Website are the property of their respective owners. The use of the word partner does not imply a partnership relationship between Cisco and any other company. (0601R)

