



# CHAPTER 1

## Overview

---

This chapter describes the PA-MC-2E1/120 and PA-MC-8E1/120 port adapters and contains the following sections:

- [Port Adapter Overview, page 1-1](#)
- [Features, page 1-4](#)
- [Compliance and Electrical Interface Specifications for E1/PRI, page 1-5](#)
- [LEDs, page 1-5](#)
- [Cables, Connectors, and Pinouts, page 1-6](#)
- [Port Adapter Slot Locations on the Supported Platforms, page 1-7](#)
- [Identifying Interface Addresses, page 1-16](#)

## Port Adapter Overview

The multichannel E1/PRI port adapters (PA-MC-2E1/120 and PA-MC-8E1/120) integrate data service unit (DSU) functionality and E1 channel support into the Cisco router.

The PA-MC-2E1/120 and PA-MC-8E1/120 provide two or eight independent E1 (120-ohm) connections via RJ-48C connectors. (See [Figure 1-1](#) and [Figure 1-2](#).) The PA-MC-8E1/120 can provide up to 128 separate full-duplex High-Level Data Link Control (HDLC) channelized E1, fractional E1, full E1, or unframed E1 interfaces and the PA-MC-2E1/120 can provide up to 62 separate full-duplex HDLC channelized E1, fractional E1, full E1, or unframed E1 interfaces.



**Note**

---

The Catalyst RSM/VIP2 and the Catalyst 6000 family FlexWAN module support the PA-MC-8E1/120 multichannel E1/PRI port adapter only.

---



**Note**

---

The Cisco 7201 router supports the PA-MC-2E1/120 multichannel E1/PRI port adapter only.

---



**Note**

---

The Cisco 7401ASR router supports the PA-MC-8E1/120 multichannel E1/PRI port adapter only.

---

**Figure 1-1 PA-MC-2E1/120 Port Adapter Front-Panel View**

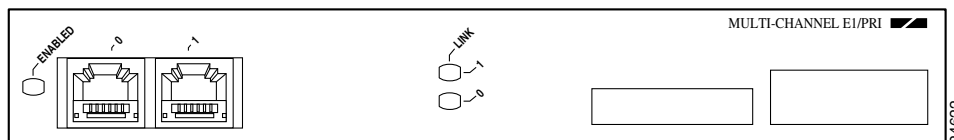

**Figure 1-2 PA-MC\_8E1/120 Port Adapter Front-Panel View**

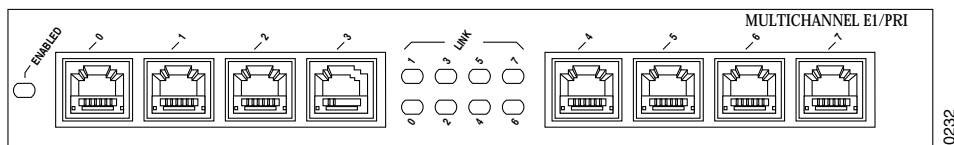

**Note** Each port adapter has a handle attached, but this handle is not shown in this publication to allow a full view of the detail on the port adapter face plate.

When you are running channelized E1, each E1 interface can provide up to 31 E1 channel groups, which are numbered from 0 to 30. Each channel group provides up to 31 64-kbps timeslots (E1 channels), which are numbered 1 to 31. Multiple timeslots can be mapped to a single channel group. Each channel group is presented to the system as a serial interface that can be configured individually. Usable bandwidth for each channel group is calculated as  $n \times 56$  kbps or  $n \times 64$  kbps, where  $n$  is a number of E1 channels (1 to 31).



**Note** The Catalyst 6000 family FlexWAN module does not support ISDN.

When you are running ISDN PRI, each E1 interface provides 30 bearer (B) channels that can transmit and receive data at the rate of 64 kbps, full-duplex, and one data (D) channel that can transmit and receive data at the rate of 64 kbps, full-duplex. The B channels are used for transmitting user data. The D channel is used for call setup control and network connection teardown, and provides the communication from the router to the ISDN switch. The B and D channels are presented to the system as serial interfaces that support HDLC and Point-to-Point Protocol (PPP) encapsulation. The multichannel E1/PRI port adapter supports dial-on-demand routing (DDR) when you are running ISDN PRI.

Each of the E1 channels on the multichannel E1/PRI port adapter uses a portion of the E1 bandwidth (fractional E1) or the entire E1 bandwidth for data transmission. Usable bandwidth for each E1 is  $n \times 64$  or  $n \times 56$  kbps, where  $n$  is a number from 1 to 31. The unused portion of the E1 bandwidth, when you are not running at full E1 speeds, cannot be used and is filled with idle channel data.



**Note** E1 timeslots on the PA-MC-2E1/120 or PA-MC-8E1/120 are numbered 1 to 31, rather than following the more traditional zero-based scheme (0 to 30) used with other Cisco products. This is to ensure consistency with telco numbering schemes for E1 channels within channelized equipment.

The PA-MC-2E1/120 or PA-MC-8E1/120 support network and payload loopbacks. Bit error rate (BER) testing is supported on each of the E1 links. The bit error rate (BER) tester can be run only on one port at a time.

The PA-MC-2E1/120 or PA-MC-8E1/120 supports the aggregation of multiple E1s (called *inverse multiplexing* or *bonding*) for higher bandwidth data rates. The PA-MC-2E1/120 or PA-MC-8E1/120 also supports Cisco HDLC, Frame Relay, PPP, and SMDS Data Exchange Interface (DXI) encapsulations over each E1 link. For SMDS only, DXI is sent on the E1 line, so it needs to connect to an SMDS switch that has direct DXI input.

Table 1-1 shows the ISDN PRI port restrictions found in the routers.

**Table 1-1 ISDN PRI Port Restrictions**

Router Platform	Port Adapter	Number of PRI Groups Allowed Per Port Adapter	Maximum Number of Interfaces Per Port Adapter	PRI-Groups Allowable Per Router
Catalyst RSM/VIP2	PA-MC-8E1/120	See information and examples that follow	128	48
Catalyst 6000 family FlexWAN	PA-MC-8E1/120	The Catalyst 6000 family FlexWAN module does not support ISDN.		
Cisco 7100 series routers	PA-MC-2E1/120 PA-MC-8E1/120	See information and examples that follow.	128	48
Cisco 7200 series routers	PA-MC-2E1/120 PA-MC-8E1/120	See information and examples that follow.	128	48
Cisco 7200 VXR routers and Cisco 7301 router	PA-MC-2E1/120 PA-MC-8E1/120	See information and examples that follow.	128	48
Cisco 7201 router	PA-MC-2E1/120	See information and examples that follow.	128	48
Cisco 7304 router (with Cisco 7304 PCI Port Adapter Carrier Card)	PA-MC-2E1/120 PA-MC-8E1/120	See information and examples that follow.	128	48
Cisco 7401ASR router	PA-MC-8E1/120	See information and examples that follow.	128	48
Cisco 7500 series routers	PA-MC-2E1/120 PA-MC-8E1/120	See information and examples that follow.	128	Both port adapters: 20 with Cisco IOS 11.2 release and Cisco IOS 11.1CA release

Rules for determining the allowable number of PRI groups per port adapter:

- Each port can have a maximum of 1 PRI group
- Each PRI group can have from 1–31 timeslots configured
- The number of channels is determined adding the number of timeslots (B channels) configured, and the 1 required D channel (per PRI group)
- The allowable number of PRI groups per port adapter is governed by the maximum number of channels supported by the hardware which is 128

Example 1: Valid configuration.

PA-MC-8E1 configured with:

1 PRI group of 10 timeslots (10 B channels + 1 D channel = 11 channels)  
1 PRI group of 20 timeslots (20 B channels + 1 D channel = 21 channels)  
1 PRI group of 15 timeslots (15 B channels + 1 D channel = 16 channels)  
1 PRI group of 31 timeslots (30 B channels + 1 D channel = 31 channels)  
1 PRI group of 31 timeslots (30 B channels + 1 D channel = 31 channels)  
Total number of channels: 110

This example is valid because 110 channels is fewer than the 128 channels maximum allowable per port adapter. In this case the 5 PRI ports can be used for the PA-MC-8E1. (Another 18 channels could be configured for a maximum of 128 [110 + 18 = 128] ports.)

Example 2: Non-valid configuration.

PA-MC-8E1 configured with:

1 PRI group of 31 timeslots (30 B channels + 1 D channel = 31 interfaces)  
1 PRI group of 31 timeslots (30 B channels + 1 D channel = 31 interfaces)  
1 PRI group of 31 timeslots (30 B channels + 1 D channel = 31 interfaces)  
1 PRI group of 31 timeslots (30 B channels + 1 D channel = 31 interfaces)  
1 PRI group of 31 timeslots (30 B channels + 1 D channel = 31 interfaces)  
Total number of interfaces: 155

This example is not valid because 155 channels exceeds the 128 channels allowable.

## Features

The PA-MC-2E1/120 or PA-MC-8E1/120 has the following features:

- Single-width port adapter in Catalyst RSM/VIP2 in Catalyst 5000 family switches, Catalyst 6000 family FlexWAN module in Catalyst 6000 family switches Cisco 7100 series routers, Cisco 7200 series routers, Cisco 7200 VXR routers, Cisco uBR7200 series routers, Cisco 7201 router, Cisco 7301 router, Cisco 7401ASR router, and for the VIP in all Cisco 7000 series routers and Cisco 7500 series routers.
- Transmits and receives data bidirectionally at the rate of 2.048 Mbps for each E1 port.
- Supports RFC 1406. For information on accessing Cisco MIB files, refer to the *Cisco MIB User Quick Reference*. For RFC 1406, Cisco supports all tables except the “Frac” table.
- Functions as a concentrator (for WANs) for a remote site.
- Conforms with ITU G.703 and G.704.
- Supports user-configurable international and national bits, set to a predetermined pattern.

# Compliance and Electrical Interface Specifications for E1/PRI

The E1/PRI line interface unit (LIU) meets the following specifications for input jitter tolerance, pulse shape/amplitude (E1), line termination, and jitter transfer:

- CCIT G.703
- CCIT G.704
- CCIT G.823

The PA-MC-2E1/120 or PA-MC-8E1/120 ports receive and transmit at the E1 level while driving and receiving from a 120-ohm unshielded twisted-pair (UTP) cable. This port adapter connects directly to any equipment that has E1 level input/output. The E1/PRI front end meets the following specifications:

- Line rate: 2.048 Mbps ( $\pm 32$  ppm)
- Line code: AMI or HDB3 (bipolar with eight-zero substitution) on the external ports
- Impedance: 120 ohms
- Pulse shape: ANSI E1.102, with pulse amplitude between 2.4 and 3.6V peak.

Table 1-2 provide the E1 channel data rates for the multichannel E1/PRI port adapter.

**Table 1-2** E1 Channel Data Rates

E1/PRI Channel Number	Data Rate
0 to 30	$n \times 56$ kbps up to full E1 (2.048 Mbps) or $n \times 64$ kbps up to full E1 (2.048 Mbps) <sup>1</sup> or Unframed mode at full E1 (2.048 Mbps)

1. Or any mixture of  $n \times 56$  and  $n \times 64$ , where  $n + n \leq 31$

## LEDs

The multichannel E1/PRI port adapter contains the ENABLED LED, standard on all port adapters, and one status LED for each port. After system initialization, the ENABLED LED goes on, indicating that the multichannel E1/PRI port adapter has been enabled for operation. (See Figure 1-3 and Figure 1-4.) The console screen also displays a message as the system discovers each interface during its reinitialization.

The following conditions must be met before the multichannel E1/PRI port adapter is enabled:

- The multichannel E1/PRI port adapter is correctly connected to the backplane and receiving power.
- The system bus recognizes the multichannel E1/PRI port adapter.
- A valid version of multichannel E1/PRI port adapter microcode is loaded and running.

If any of these conditions is not met, or if the initialization fails for other reasons, the ENABLED LED does not go on.

**Figure 1-3 PA-MC-2E1 LEDs (Horizontal Orientation)**

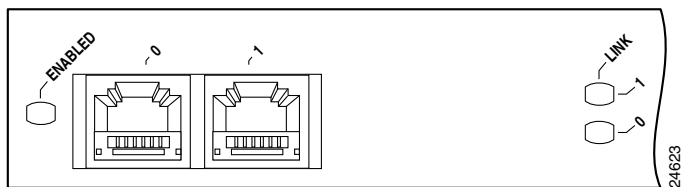

**Figure 1-4 PA-MC-8E1 LEDs (Horizontal Orientation)**

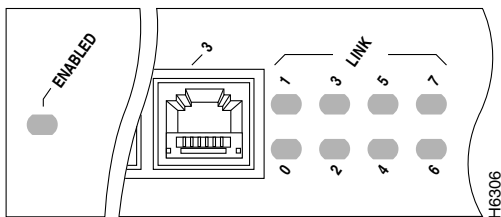

Table 1-3 lists the LED colors and indications.

**Table 1-3 PA-MC-2E1 or PA-MC-8E1 LEDs**

LED Label	Color	State	Meaning
ENABLED	—	On	PA-MC-2E1 or PA-MC-8E1 is enabled.
LINK LEDs—0-1 for the PA-MC-2E or 0-7 for the PA-MC-8E1	—	On	The port is active.

## Cables, Connectors, and Pinouts

The E1/PRI interface receptacles on the multichannel E1/PRI port adapter are RJ-48C receptacles for E1 (120-ohm). You can use them all simultaneously. Each connection supports E1 (120-ohm) interfaces that meet G.703 standards. The RJ-48C connection does not require an external transceiver. The E1/PRI ports are E1 interfaces that use 120-ohm unshielded twisted pair cables. (See Figure 1-5.)



**Note**

To meet VCCI Class II EMI requirements, you must use foil twisted pair (FTP) cables.

Figure 1-5 and Table 1-4 show the multichannel E1/PRI port adapter interface cable, connector, and pinout.

**Figure 1-5 Multichannel E1/PRI Interface Cable and Connector**

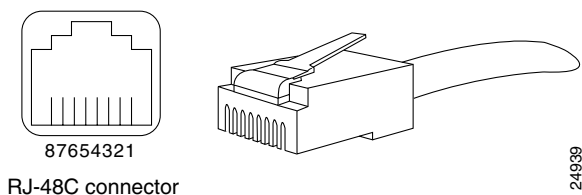

Table 1-4 lists the signal pinouts and descriptions for the RJ-48C connector.

**Table 1-4 120-ohm RJ-48C Connector Pinout**

Pin	Signal <sup>1</sup>
1	RX ring
2	RX tip
3	NC
4	TX ring
5	TX tip
6	NC
7	NC
8	NC

1. TX = transmit. RX = receive.  
NC = no connect.

## Port Adapter Slot Locations on the Supported Platforms

This section discusses port adapter slot locations on the supported platforms. The illustrations that follow summarize slot location conventions on each platform. This section includes the following subsections:

- [Catalyst RSM/VIP2 Slot Numbering, page 1-7](#)
- [Catalyst 6000 Family FlexWAN Module Slot Numbering, page 1-8](#)
- [Cisco 7100 Series Routers Slot Numbering, page 1-10](#)
- [Cisco 7200 Series Routers and Cisco uBR7200 Series Routers Slot Numbering, page 1-11](#)
- [Cisco 7201 Router Slot Numbering, page 1-12](#)
- [Cisco 7301 Router Slot Numbering, page 1-13](#)
- [Cisco 7304 PCI Port Adapter Carrier Card Slot Numbering, page 1-13](#)
- [Cisco 7401ASR Router Slot Numbering, page 1-14](#)
- [Cisco 7000 Series Routers and Cisco 7500 Series Routers VIP Slot Numbering, page 1-15](#)

### Catalyst RSM/VIP2 Slot Numbering

The Catalyst RSM/VIP2 can be installed in any slot in a Catalyst 5000 family switch except the top slots, which contain the supervisor engines. The Catalyst RSM/VIP2 does not use interface processor slot numbering; therefore, slots are not numbered. The PA-MC-8E1/120 can be installed into either port adapter slot 0 or slot 1 on a Catalyst RSM/VIP2. [Figure 1-6](#) shows a Catalyst 5000 family switch with two port adapters installed in a Catalyst RSM/VIP2.



#### Note

The Catalyst RSM/VIP2 supports the PA-MC-8E1/120 multichannel E1/PRI port adapter only.

**Note**

The Catalyst 5500 switch has 13 slots. Slot 1 is reserved for the supervisor engine. If a redundant supervisor engine is used, it would go in slot 2; otherwise, slot 2 can be used for other modules. Slot 13 is a dedicated slot, reserved for the ATM Switch Processor (ASP) module. Refer to the *Catalyst 5000 Series Route Switch Module Installation and Configuration Note* for any additional slot restrictions for the Catalyst RSM/VIP2.

**Figure 1-6 Catalyst 5000 Family Switch with Port Adapters Installed on Catalyst RSM/VIP2**

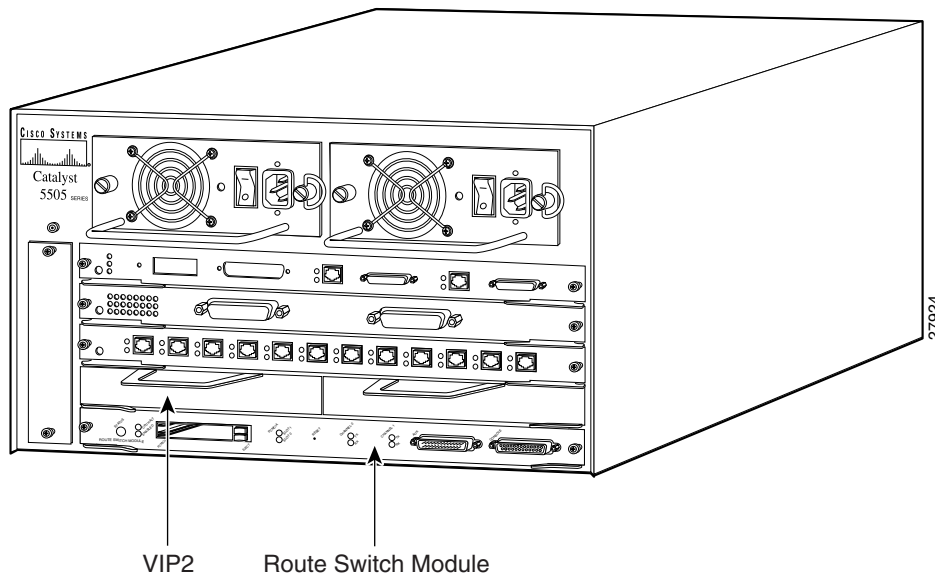

## Catalyst 6000 Family FlexWAN Module Slot Numbering

The Catalyst 6000 family FlexWAN module can be installed in any slot of a Catalyst 6000 family switch except slot 1, which is reserved for the supervisor engine. The PA-MC-8E1/120 can be installed into either port adapter bay 0 or bay 1 on a FlexWAN module. [Figure 1-7](#) shows a FlexWAN module with two blank port adapters installed.

**Note**

The Catalyst 6000 family FlexWAN module supports the PA-MC-8E1/120 multichannelE1/PRI port adapter only.

**Note**

Slot 1 is reserved for the supervisor engine. If a redundant supervisor engine is used, it would go in slot 2; otherwise, slot 2 can be used for other modules.

Figure 1-7 Catalyst 6000 Family Switch with Port Adapters Installed on FlexWAN Module

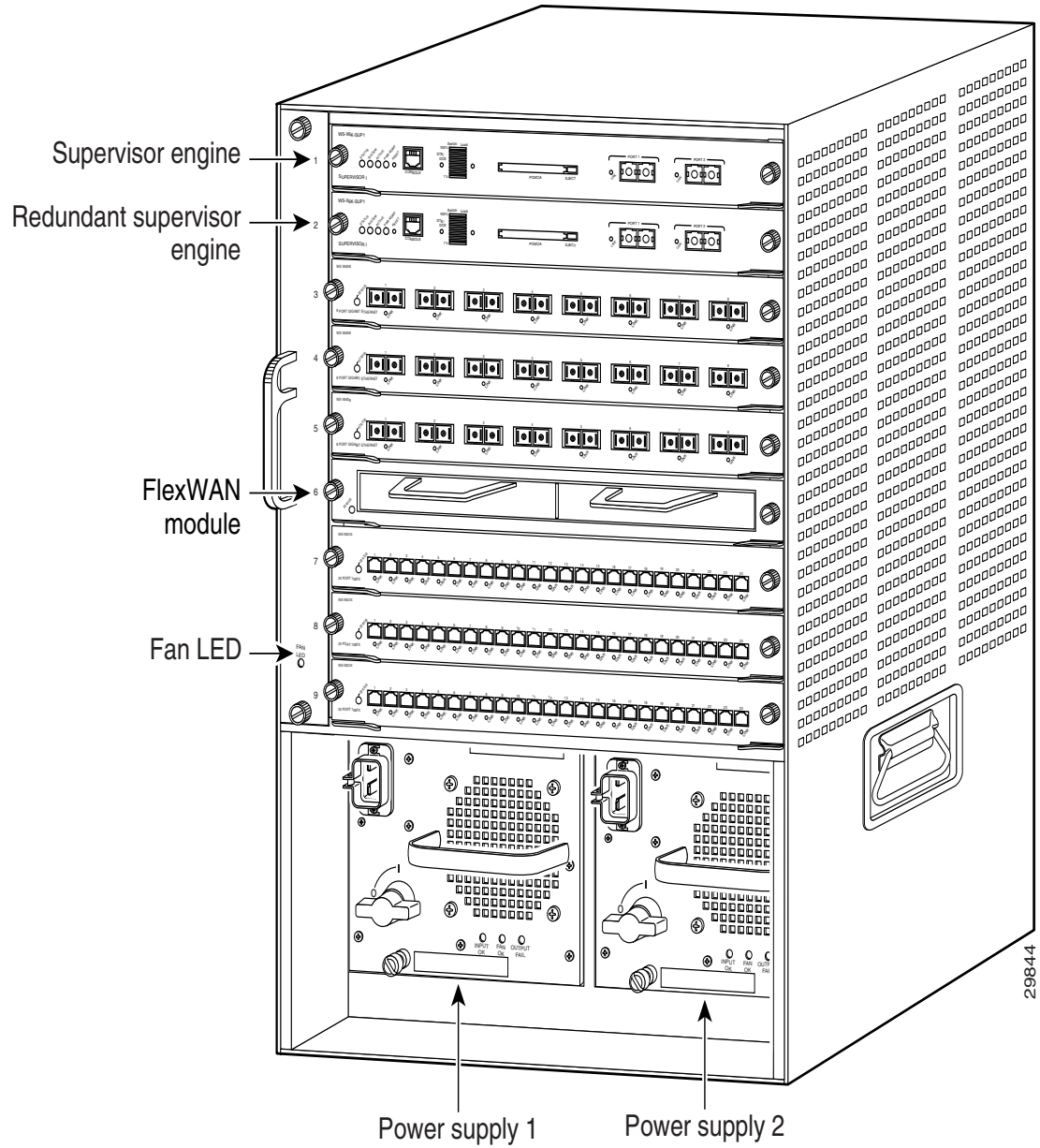

## Cisco 7100 Series Routers Slot Numbering

The PA-MC-2E1/120 or PA-MC-8E1/120 can be installed in port adapter slot 3 in Cisco 7120 series routers, and in port adapter slot 4 in Cisco 7140 series routers. [Figure 1-8](#) shows the slot numbering on a Cisco 7120 series router. [Figure 1-9](#) shows the slot numbering on a Cisco 7140 series router.

**Figure 1-8** Port Adapter Slots in the Cisco 7120 Series Router

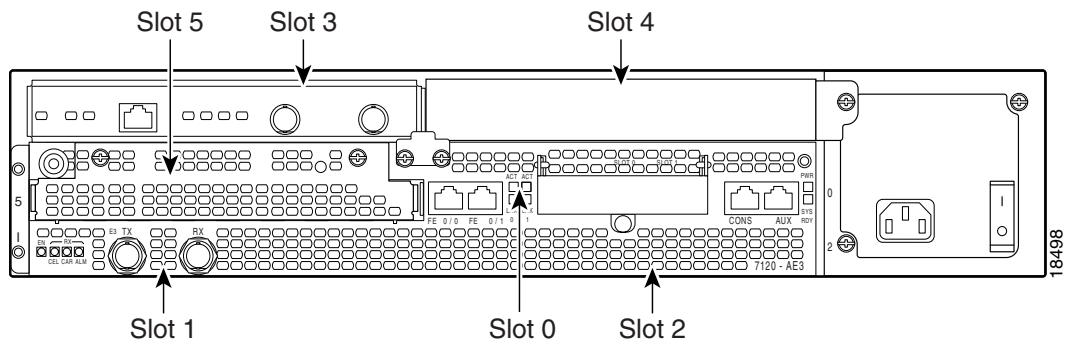

**Figure 1-9** Port Adapter Slots in the Cisco 7140 Series Router

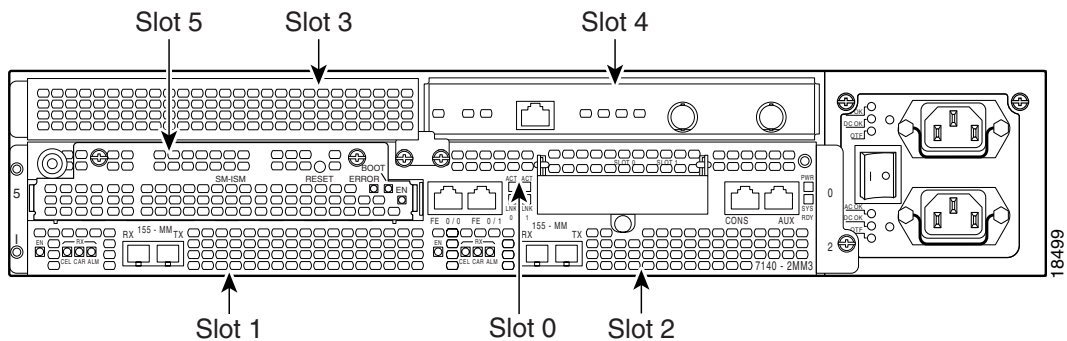

## Cisco 7200 Series Routers and Cisco uBR7200 Series Routers Slot Numbering

Cisco 7202 routers have two port adapter slots. The slots are numbered from left to right. You can place a PA-MC-2E1/120 or PA-MC-8E1/120 in either of the slots (slot 1 or slot 2). The Cisco 7202 router is not shown.

Cisco 7204 routers and Cisco 7204VXR routers have four slots for port adapters, and one slot for an input/output (I/O) controller. The slots are numbered from the lower left to the upper right, beginning with slot 1 and continuing through slot 4. You can place a PA-MC-2E1/120 or PA-MC-8E1/120 in any of the slots (slot 1 through slot 4). Slot 0 is always reserved for the I/O controller. The Cisco 7204 router and Cisco 7204VXR router are not shown.

Cisco 7206 routers and Cisco 7206VXR routers (including the Cisco 7206 and Cisco 7206VXR routers as router shelves in a Cisco AS5800 Universal Access Server) have six slots for port adapters, and one slot for an input/output (I/O) controller. The slots are numbered from the lower left to the upper right, beginning with slot 1 and continuing through slot 6. You can place a PA-MC-2E1/120 or PA-MC-8E1/120 in any of the six slots (slot 1 through slot 6). Slot 0 is always reserved for the I/O controller. [Figure 1-10](#) shows the slot numbering on a Cisco 7206 router. The Cisco 7206VXR router is not shown.

**Figure 1-10** Port Adapter Slots in the Cisco 7206 Router

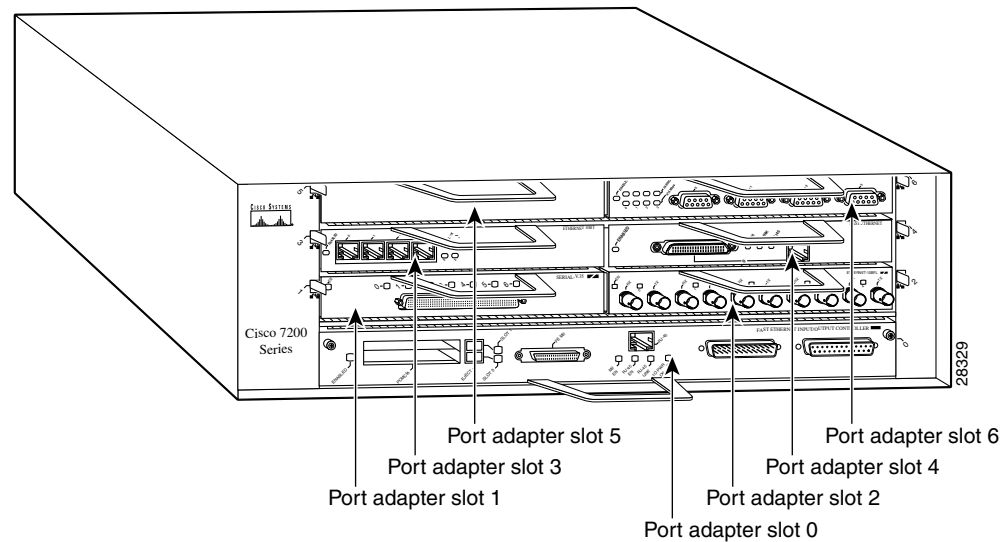

## Cisco uBR7200 Series Router Slot Numbering

The Cisco uBR7223 router has one port adapter slot (slot 1). Slot 0 is always reserved for the I/O controller—if present. The Cisco uBR7223 router is not shown.

The Cisco uBR7246 router and Cisco uBR7246VXR router have two port adapter slots (slot 1 and slot 2). Slot 0 is always reserved for the I/O controller—if present. [Figure 1-11](#) shows the slot numbering of port adapters on a Cisco uBR7246 and Cisco uBR7246VXR router.

**Figure 1-11** Port Adapter Slots in the Cisco uBR7246 or Cisco uBR7246VXR Router

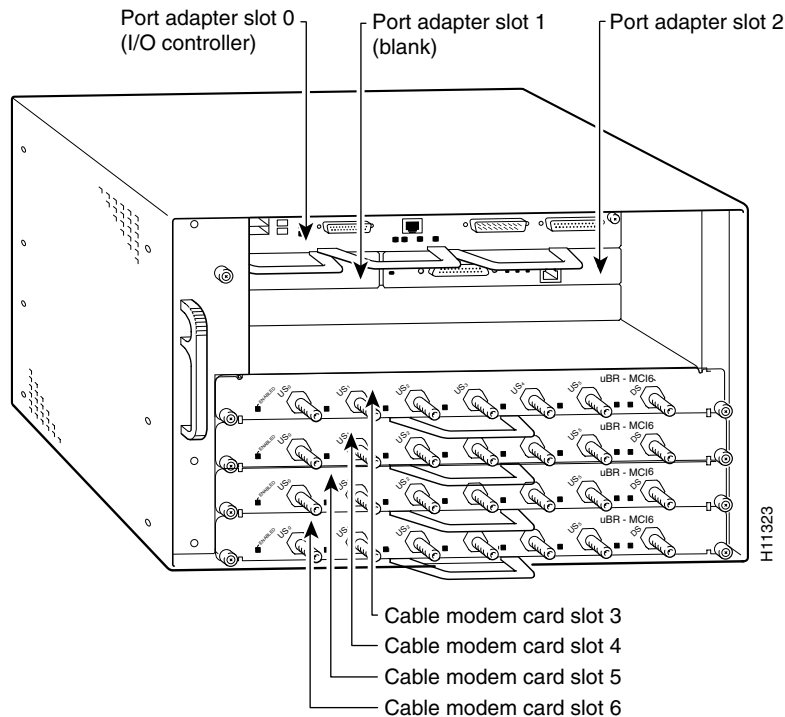

## Cisco 7201 Router Slot Numbering

[Figure 1-12](#) shows the front view of a Cisco 7201 router with a port adapter installed. There is only one port adapter slot (slot 1) in a Cisco 7201 router.

**Figure 1-12** Port Adapter Slot in the Cisco 7201 Router

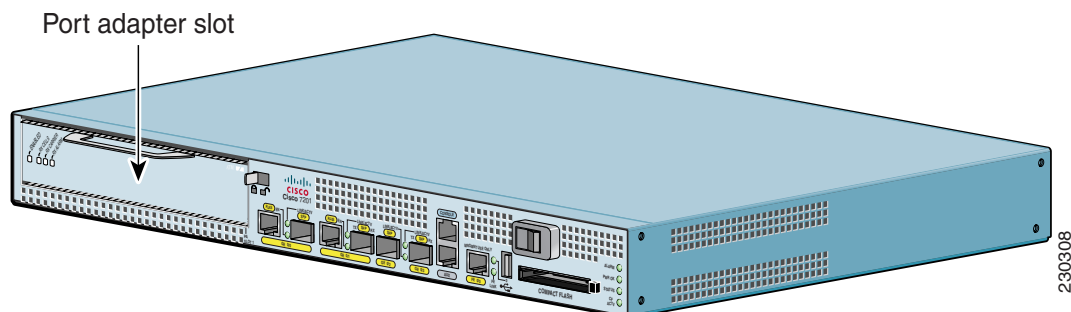

## Cisco 7301 Router Slot Numbering

Figure 1-13 shows the front view of a Cisco 7301 router with a port adapter installed. There is only one port adapter slot (slot 1) in a Cisco 7301 router.

**Figure 1-13** Port Adapter Slot in the Cisco 7301 Router

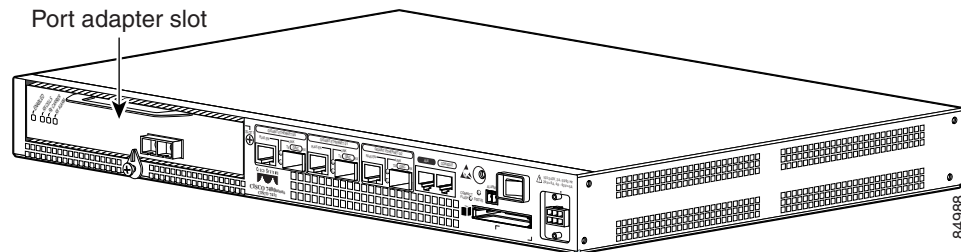

## Cisco 7304 PCI Port Adapter Carrier Card Slot Numbering

The Cisco 7304 PCI Port Adapter Carrier Card installs in Cisco 7304 router module slots 2 through 5. Figure 1-14 shows a Cisco 7304 PCI Port Adapter Carrier Card with a port adapter installed. The Cisco 7304 PCI Port Adapter Carrier Card accepts one single-width port adapter.

Figure 1-15 shows the module slot numbering on a Cisco 7304 router. The port adapter slot number is the same as the module slot number. Slot 0 and slot 1 are reserved for the NPE module or NSE module.

**Figure 1-14** Cisco 7304 PCI Port Adapter Carrier Card—Port Adapter Installed

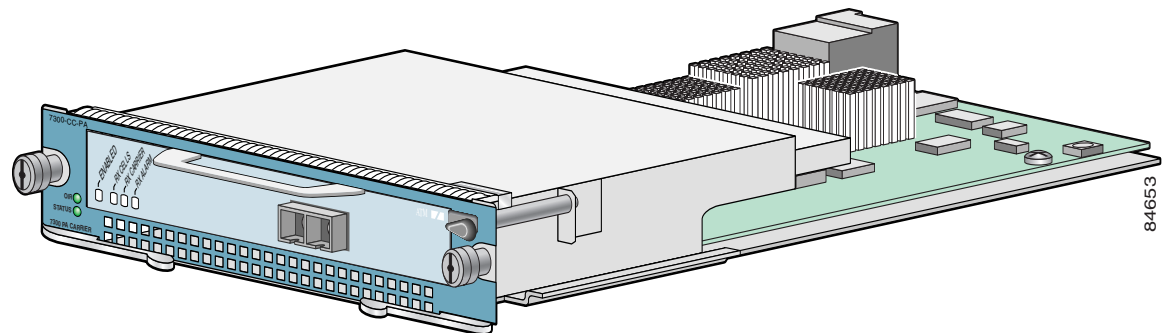

**Figure 1-15** Module Slots on the Cisco 7304 Router

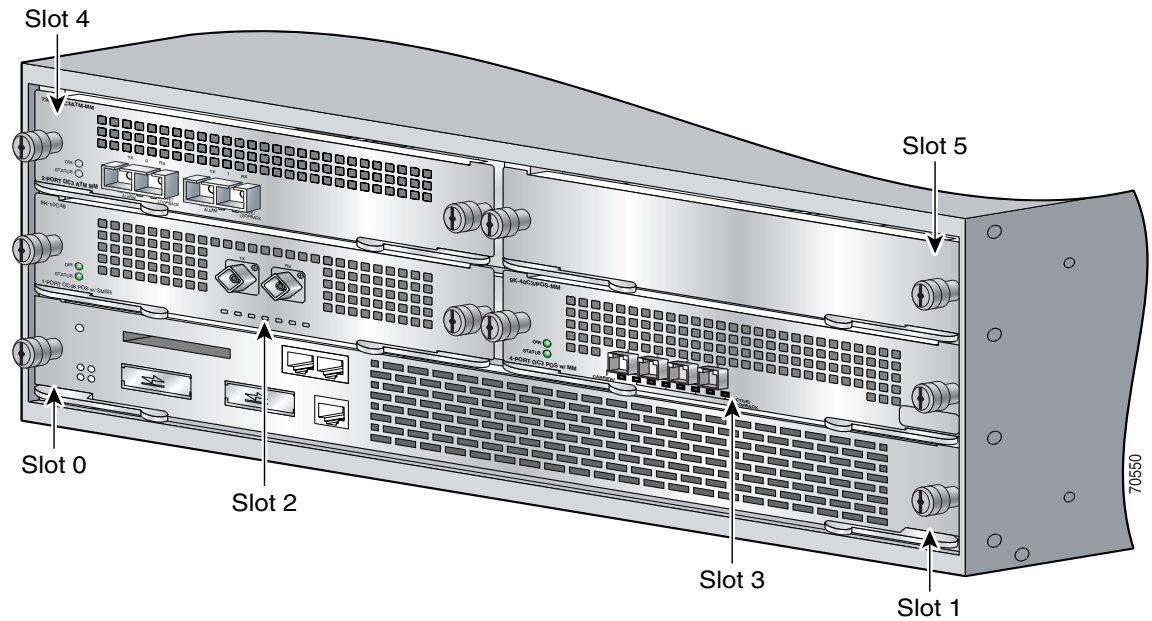

## Cisco 7401ASR Router Slot Numbering

Figure 1-16 shows the front view of a Cisco 7401ASR router with a port adapter installed. There is only one port adapter slot (slot 1) in a Cisco 7401ASR router.

**Figure 1-16** Port Adapter Slot in the Cisco 7401ASR Router

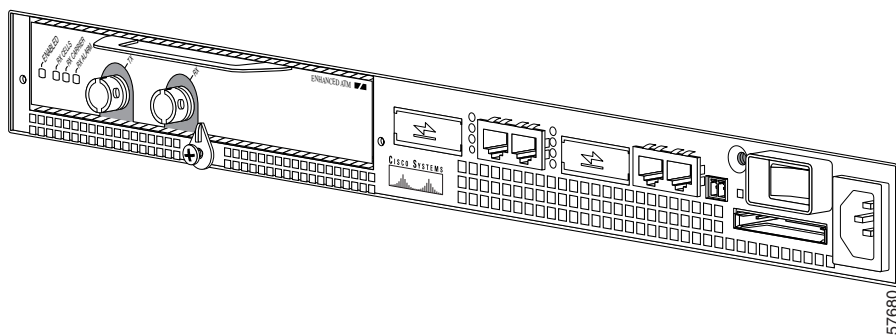

## Cisco 7000 Series Routers and Cisco 7500 Series Routers VIP Slot Numbering

The PA-MC-2E1 and PA-MC-8E1 are supported on the VIPs (versatile interface processors) used in Cisco 7000 series and Cisco 7500 series routers. In the Cisco 7010 router and Cisco 7505 router, the VIP motherboard is installed horizontally in the VIP slot. In the Cisco 7507 router and Cisco 7513 router, the VIP motherboard is installed vertically in the VIP slot. The PA-MC-2E1/120 or PA-MC-8E1/120 can be installed in either bay (port adapter slot 0 or 1) on the VIP. The bays are numbered from left to right on the VIP. [Figure 1-17](#) shows the slot numbering on a VIP.

**Figure 1-17** VIP Slot Locations

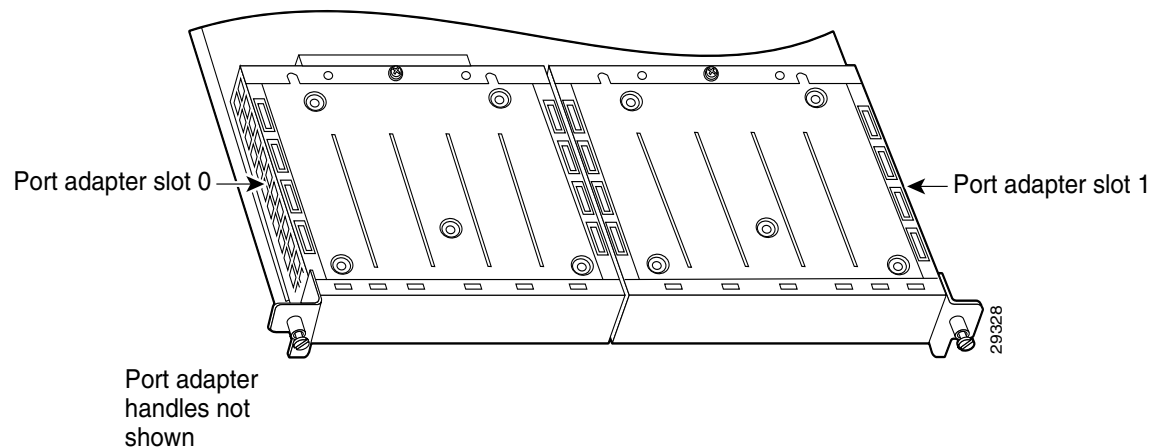

Cisco 7010 routers have three slots for port adapters, and two slots for Route Switch Processors (RSPs). The slots are numbered from bottom to top. You can place the PA-MC-2E1/120 or PA-MC-8E1/120 in any of the VIP interface slots (slot 0 through 2). Slots 3 and 4 are always reserved for RSPs. The Cisco 7010 router is not shown.

Cisco 7505 routers have four slots for port adapters, and one slot for an RSP. The slots are numbered from bottom to top. You can place the PA-MC-2E1/120 or PA-MC-8E1/120 in any of the VIP interface slots (slot 0 through 3). One slot is always reserved for the RSP. [Figure 1-18](#) shows the slot numbering on a Cisco 7505 router.

**Figure 1-18** VIP Slots in the Cisco 7505 Router

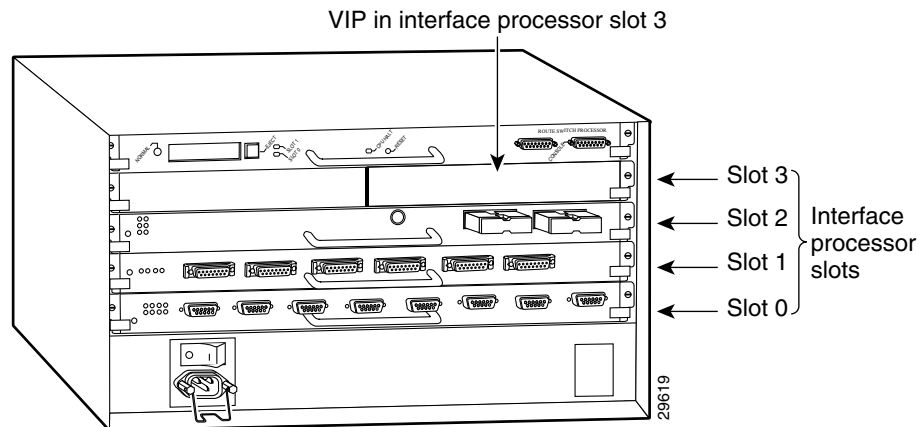

Cisco 7507 routers have five slots for port adapters, and two slots for RSPs. The slots are numbered from left to right. You can place the PA-MC-2E1/120 or PA-MC-8E1/120 in any of the VIP interface slots (slot 0, 1, 4, 5, or 6). Slots 2 and 3 are always reserved for RSPs. The Cisco 7507 router is not shown.

Cisco 7513 routers have eleven slots for port adapters, and two slots for RSPs. The slots are numbered from left to right. You can place the PA-MC-2E1/120 or PA-MC-8E1/120 in any of the VIP interface slots (slots 0 through 5, or slots 9 through 12). Slots 6 and 7 are always reserved for RSPs. The Cisco 7513 router is not shown.

## Identifying Interface Addresses

This section describes how to identify interface addresses for the PA-MC-2E1/120 or PA-MC-8E1/120 in the supported platforms. Interface addresses specify the actual physical location of each interface on a router or switch.

Interfaces on a PA-MC-2E1/120 and PA-MC-8E1/120 installed in a router maintain the same address regardless of whether other port adapters are installed or removed. However, when you move a port adapter to a different slot, the first number in the interface address changes to reflect the new port adapter slot number.

Interfaces on a PA-MC-2E1/120 and PA-MC-8E1/120 installed in a VIP or FlexWAN module maintain the same address regardless of whether other interface processors or modules are installed or removed. However, when you move a VIP or FlexWAN module to a different slot, the interface processor or module slot number changes to reflect the new interface processor or module slot.

**Note**

---

Interface ports are numbered from left to right starting with 0.

---

**Note**

---

E1 timeslots on the multichannel E1/PRI port adapter are numbered 1 to 31, rather than following the more traditional zero-based scheme (0 to 30) used with other Cisco products. This is to ensure consistency with telco numbering schemes for E1 channels within channelized E1 equipment.

---

This section includes the following subsections:

- [Catalyst RSM/VIP2 Interface Addresses, page 1-18](#)
- [Catalyst 6000 Family FlexWAN Module Interface Addresses, page 1-19](#)
- [Cisco 7100 Series Routers Interface Addresses, page 1-19](#)
- [Cisco 7200 Series and Cisco uBR7200 Series Routers Interface Addresses, page 1-19](#)
- [Cisco 7201 Router Interface Address, page 1-20](#)
- [Cisco 7301 Router Interface Address, page 1-20](#)
- [Cisco 7304 PCI Port Adapter Carrier Card Interface Addresses, page 1-21](#)
- [Cisco 7401ASR Router Interface Addresses, page 1-21](#)
- [Cisco 7000 Series Routers and Cisco 7500 Series Routers VIP Interface Addresses, page 1-21](#)

Table 1-5 summarizes the interface address formats for the supported routers.

**Table 1-5 Identifying Interface Addresses**

Platform	Interface Address Format	Numbers	Syntax
Catalyst RSM/VIP2 in Catalyst 5000 family switches	Port-adapter-slot-number/interface-port-number: channel-group-number	Port adapter slot—0 or 1 Interface port—0 through 7 Channel group—0 to 30	0/1:1
Catalyst 6000 family FlexWAN module in Catalyst 6000 family switches	Module-slot-number/port-adapter-bay-number/ interface-port-number:channel-group-number	Module slot—2 <sup>1</sup> through 13 (depends on the number of slots in the switch) Port adapter bay—0 or 1 Interface port—0 through 7 Channel group—0 to 30	3/0/0:1
Cisco 7120 series router	Port-adapter-slot-number/interface-port-number: channel-group-number	Port adapter slot—always 3 Interface port—0 through 1, or 0 through 7 Channel group—0 to 30	3/1:1
Cisco 7140 series router	Port-adapter-slot-number/interface-port-number: channel-group-number	Port adapter slot—always 4 Interface port—0 through 1, or 0 through 7 Channel group—0 to 30	4/0:1
Cisco 7200 series routers and Cisco 7200 VXR routers	Port-adapter-slot-number/interface-port-number: channel-group-number	Port adapter slot—1 through 6 (depends on the number of slots in the router) <sup>2</sup> Interface port—0 through 1, or 0 to 7 Channel group—0 to 30	1/0:1
Cisco 7201 router	Port-adapter-slot-number/interface-port-number: channel-group-number	Port adapter slot—always 1 Interface port—0 through 1 Channel group—0 to 30	1/0:1
Cisco uBR7223 router	Port-adapter-slot-number/interface-port-number: channel-group-number	Port adapter slot—1 <sup>2</sup> Interface port—0 through 1, or 0 to 7 Channel group—0 to 30	1/0:19
Cisco uBR7246 and Cisco uBR7246VXR routers	Port-adapter-slot-number/interface-port-number: channel-group-number	Port adapter slot—1 or 2 <sup>2</sup> Interface port—0 through 1, or 0 through 7 Channel group—0 to 30	1/2:1

Table 1-5 Identifying Interface Addresses (continued)

Platform	Interface Address Format	Numbers	Syntax
Cisco 7301 router	Port-adapter-slot-number/interface-port-number: channel-group-number	Port adapter slot—always 1 Interface port—0 through 1, or 0 through 7 Channel group—0 to 30	1/0:1
Cisco 7304 PCI Port Adapter Carrier Card in Cisco 7304 router	Module-slot-number/interface-port-number: channel-group-number	Module slot— slot 2 through 5 Interface port—0 through 1, or 0 through 7 Channel group—0 to 30	3/0:1
Cisco 7401ASR router	Port-adapter-slot-number/interface-port-number: channel-group-number	Port adapter slot—always 1 Interface port—0 through 7 Channel group—0 to 30	1/0:1
VIP in Cisco 7000 series or Cisco 7500 series routers	Interface-processor-slot-number/port-adapter-slot -number/interface-port-number:channel-group- number	Interface processor slot—0 through 12 (depends on the number of slots in the router) Port adapter slot—0 or 1 Interface port—0 through 1, or 0 through 7 Channel group—0 to 30	3/1/0:1

- Slot 1 is reserved for the supervisor engine. If a redundant supervisor engine is used, it must go in slot 2; otherwise, slot 2 can be used for other modules.
- Port adapter slot 0 is reserved for the Fast Ethernet port on the I/O controller (if present).

## Catalyst RSM/VIP2 Interface Addresses

In Catalyst 5000 family switches, the Catalyst RSM/VIP2 can be installed in any slot except the top slots, which contain the supervisor engine modules. The Catalyst RSM/VIP2 in a Catalyst 5000 family switch does not use interface processor slot numbering; therefore, the slots in which it is installed are not numbered. A port adapter can be installed into either port adapter slot 0 or slot 1 on a Catalyst RSM/VIP2. See [Figure 1-6](#).

The interface address is composed of a three-part number in the format *port-adapter-slot number/interface-port number:channel-group-number*. See [Table 1-5](#). For example, if an eight-port PA-MC-8E1/120 is installed in slot 1, channel 1, on a Catalyst RSM/VIP2, the interface addresses would be 1/0:1, 1/1:1, 1/2:1, 1/3:1, 1/4:1, 1/5:1, 1/6:1, and 1/7:1 (port adapter slot 1 interface ports 0 through 7, and channel group 1).



### Note

The Catalyst RSM/VIP2 supports the PA-MC-8E1/120 only.

## Catalyst 6000 Family FlexWAN Module Interface Addresses

The Catalyst 6000 family FlexWAN module can be installed in module slots 2 through 13 (depending on the number of slots in the router). Slot 1 is reserved for the supervisor engine. A port adapter can be installed into either port adapter bay 0 or bay 1 on a FlexWAN module. See [Figure 1-7](#).

The interface address is composed of a four-part number in the format *module-number/port-adapter-bay-number/interface-port-number:channel-group-number*. See [Table 1-5](#).

The first number identifies the module slot of the chassis in which the FlexWAN module is installed (slot 2 through slot 3, 6, 9, or 13 depending on the number of slots in the chassis). These module slots are generally numbered from top to bottom, starting with 1.

The second number identifies the bay of the FlexWAN module in which the port adapter is installed (0 or 1). The bays are numbered from left to right on the FlexWAN module.

The third number identifies the physical port number on the port adapter. The PA-MC-8E1/120 is an eight-port port adapter, therefore the port can be 0 through 7.

The fourth number identifies the logical channel group and is a number from 0 through 30.

For example, if an eight-port PA-MC-8E1/120 is installed in the FlexWAN module in module slot 3, port adapter bay 0, channel 1, the interface addresses would be 3/0/0:1 through 3/0/7:1 (module slot 3, port adapter bay 0, interface ports 0 through 7, and channel group 1).

**Note**

The FlexWAN module supports the PA-MC-8E1/120 only.

**Note**

The FlexWAN module physical port address begins with slot 0, which differs from the conventional Catalyst 6000 family port address, which begins with slot 1.

## Cisco 7100 Series Routers Interface Addresses

In Cisco 7120 series router, port adapters are installed in port adapter slot 3. See [Figure 1-8](#). In the Cisco 7140 series router, port adapters are installed in port adapter slot 4. See [Figure 1-9](#).

The interface address is composed of a three-part number in the format *port-adapter-slot-number/interface-port-number:channel-group-number*. See [Table 1-5](#). For example, if a dual-port PA-MC-2E1/120 is installed on channel 1 of a Cisco 7120 router, the interface addresses would be 3/0:1 and 3/1:1. If a dual-port PA-MC-2E1 is installed on a Cisco 7140 router, the interface addresses would be 4/0:1 and 4/1:1.

## Cisco 7200 Series and Cisco uBR7200 Series Routers Interface Addresses

In Cisco 7200 series routers and Cisco 7200 VXR routers, port adapter slots are numbered from the lower left to the upper right, beginning with slot 1 and continuing through slot 2 for the Cisco 7202, slot 4 for the Cisco 7204 and Cisco 7204VXR, and slot 6 for the Cisco 7206 and Cisco 7206VXR. Port adapters can be installed in any available port adapter slot from 1 through 6 (depending on the number of slots in the router). (Slot 0 is reserved for the I/O controller.) See [Figure 1-10](#).

The interface address is composed of a three-part number in the format *port-adapter-slot-number/interface-port-number:channel-group-number*. See [Table 1-5](#). For example, if a dual-port PA-MC-2E1/120 is installed in slot 1, channel 1, on a Cisco 7200 series router, the

interface addresses would be 1/0:1 and 1/1:1. If an eight-port PA-MC-8E1/120 is installed in slot 1, channel 1, on a Cisco 7200 series router, the interface address would be 1/0:1, 1/1:1, 1/2:1, 1/3:1, 1/4:1, 1/5:1, 1/6:1, and 1/7:1 (port adapter slot 1 interface ports 0 through 7, and channel group 1).

## Cisco uBR7200 Series Routers Interface Addresses

In the Cisco uBR7223 router, only one slot accepts port adapters and it is numbered slot 1.

In the Cisco uBR7246 router and Cisco uBR7246VXR router, port adapters can be installed in two port adapter slots (slot1 and slot 2). Slot 0 is always reserved for the I/O controller—if present. See [Figure 1-11](#).

The interface address is composed of a three-part number in the format *port-adapter-slot-number/interface-port-number:channel-group-number*. See [Table 1-5](#). For example, if a dual-port PA-MC-2E1/120 is installed in channel 1 of a Cisco uBR7223 router, the interface addresses would be 1/0:1 and 1/1:1 (port adapter slot 1 interface ports 0 and 1, and channel group 1). If an eight-port PA-MC-8E1/120 is installed slot 2, channel 1, of a Cisco uBR7246 router, the interface addresses would be 2/0:1, 2/1:1, 2/2:1, 2/3:1, 2/4:1, 2/5:1, 2/6:1, and 2/7:1 (port adapter slot 2 interface ports 0 through 7, and channel group 1).

## Cisco 7201 Router Interface Address

In the Cisco 7201 router, only one slot accepts port adapters and it is numbered as slot 1. See [Figure 1-12](#).

The interface address is composed of a three-part number in the format *port-adapter-slot-number/interface-port-number:channel-group-number*. See [Table 1-5](#). For example, if a dual-port PA-MC-2E1/120 is installed on channel 1 of a Cisco 7201 router, the interface addresses would be 1/0:1 and 1/1:1 (port adapter slot 1 interface ports 0 and 1, and channel group 1).

**Note**

---

The Cisco 7201 router supports the PA-MC-2E1/120 only.

---

## Cisco 7301 Router Interface Address

In the Cisco 7301 router, only one slot accepts port adapters and it is numbered as slot 1. See [Figure 1-13](#).

The interface address is composed of a three-part number in the format *port-adapter-slot-number/interface-port-number:channel-group-number*. See [Table 1-5](#). For example, if a dual-port PA-MC-2E1/120 is installed on channel 1 of a Cisco 7301 router, the interface addresses would be 1/0:1 and 1/1:1 (port adapter slot 1 interface ports 0 and 1, and channel group 1). If an eight-port PA-MC-8E1/120 is installed on channel 1 of a Cisco 7301 router, the interface addresses would be 2/0:1, 2/1:1, 2/2:1, 2/3:1, 2/4:1, 2/5:1, 2/6:1, and 2/7:1 (port adapter slot 2 interface ports 0 through 7, and channel group 1).

## Cisco 7304 PCI Port Adapter Carrier Card Interface Addresses

In the Cisco 7304 router, port adapters are installed in a Cisco 7304 PCI port adapter carrier card, which installs in Cisco 7304 router module slots 2 through 5. The port adapter slot number is the same as the module slot number. See [Figure 1-14](#) and [Figure 1-15](#).

The interface address is composed of a three-part number in the format *module-slot-number/interface-port-number:channel-group-number*. See [Table 1-5](#). For example, if a dual-port PA-MC-2E1/120 is installed in the Cisco 7304 PCI port adapter carrier card in Cisco 7304 router module slot 3, channel 1, the interface addresses would be 3/0:1 and 3/1:1 (port adapter slot 3 interface ports 0 and 1, and channel group 1). If an eight-port PA-MC-8E1/120 is installed in the Cisco 7304 PCI port adapter carrier card in Cisco 7304 router module slot 3, the interface addresses would be 3/0:1, 3/1:1, 3/2:1, 3/3:1, 3/4:1, 3/5:1, 3/6:1, and 3/7:1 (port adapter slot 3 interface ports 0 through 7, and channel group 1).

## Cisco 7401ASR Router Interface Addresses

In the Cisco 7401ASR router, only one slot accepts port adapters and it is numbered as slot 1. See [Figure 1-16](#).

The interface address is composed of a three-part number in the format *port-adapter-slot-number/interface-port-number:channel-group-number*. See [Table 1-5](#). For example, if an eight-port PA-MC-8E1/120 is installed on channel 1 of a Cisco 7401ASR router, the interface addresses would be 2/0:1, 2/1:1, 2/2:1, 2/3:1, 2/4:1, 2/5:1, 2/6:1, and 2/7:1 (port adapter slot 2 interface ports 0 through 7, and channel group 1).

**Note**

---

The Cisco 7401ASR router supports the PA-MC-8E1/120 only.

---

## Cisco 7000 Series Routers and Cisco 7500 Series Routers VIP Interface Addresses

In Cisco 7000 series routers and Cisco 7500 series routers, port adapters are installed on a versatile interface processor (VIP), which installs in interface processor slots 0 through 12 (depending on the number of slots in the router). The port adapter can be installed in either bay (port adapter slot 0 or 1) on the VIP. See [Figure 1-17](#), and [Figure 1-18](#).

The interface address for the VIP is composed of a four-part number in the format *interface-processor-slot-number/port-adapter-slot-number/interface-port-number:channel-group-number*. See [Table 1-5](#).

The first number identifies the slot in which the VIP is installed (slot 0 through 12, depending on the number of slots in the router).

The second number identifies the bay (port adapter slot) on the VIP in which the port adapter is installed (0 or 1). The bays are numbered from left to right on the VIP.

The third number identifies the physical port number (interface port number) on the port adapter. The port numbers always begin at 0 and are numbered from left to right. The number of additional ports depends on the number of ports on the port adapter. The PA-MC-2E1/120 is a dual-port port adapter, therefore the port can be 0 or 1. The PA-MC-8E1/120 are eight-port port adapters, therefore their port can be 0 through 7.

The fourth number identifies the logical channel group and is a number from 0 through 30.

For example, if a dual-port PA-MC-2T1 is installed in a VIP in interface processor slot 3, port adapter slot 1, channel 1, the interface addresses would be 3/1/0:1 and 3/1/1:1 (interface processor slot 3, port adapter slot 1, interface ports 0 and 1, and channel group 1). If an eight-port PA-MC-8E1/120 is installed in a VIP in interface processor slot 3, port adapter slot 1, channel 1, the interface addresses would be 3/1/0:1, 3/1/1:1, 3/1/2:1, 3/1/3:1, 3/1/4:1, 3/1/5:1, 3/1/6:1, and 3/1/7:1 (interface processor slot 3, port adapter slot 1, interface ports 0 through 7, and channel group 1).

**Note**

---

Although the processor slots in the seven-slot Cisco 7000 and Cisco 7507 routers and the thirteen-slot Cisco 7513 router are vertically oriented and those in the five-slot Cisco 7010 and Cisco 7505 routers are horizontally oriented, all Cisco 7000 series and Cisco 7500 series routers use the same method for slot and port numbering.

---