

Figure 1. CNTBLOCK, Network Terminal Block

DESCRIPTION:

Functional Description

The CNTBLOCK, illustrated in figure 1, is a network terminal expander and diagnostic tool for the CRESNET II remote control system (herein referred to as the CRESNET II system). The eight network connectors on the CNTBLOCK are setup as two sets of four. Power can be isolated between the two sets by disconnecting a jumper on the board. The unit provides LED indicators which help isolate wiring problems.

Physical Description

The CNTBLOCK is housed in a black enclosure with a silk-screened top panel (refer to figure 1). Three LEDs are located toward the center of the top panel: a green LED (POWER) and two red LEDs (NORM ON (Y) and NORM OFF (Z)). Eight four-pin network connectors are accessible from the two longest side panels of the unit (four per side).

For stability two Dual Lock fasteners are supplied with the unit, but unattached. If desired, the fasteners may be applied to the underside of the CNTBLOCK. At the shorter sides of the unit, the enclosure extends to form feet at a right angle to the side. There are three holes per foot for inserting screws to further stabilize the unit.

LEADING SPECIFICATIONS:

Table 1 provides a summary of leading specifications for the CNTBLOCK. Dimensions and weight are approximations rounded to the nearest tenth unit.

Table 1. Leading Specifications

SPECIFICATION	DETAILS
Power Requirements	+ 24 VDC
Dimensions & Weight	Height: 1.9 in (4.8 cm)
	Width: 5.8 in (14.7 cm)
	Depth: 0.9 in (2.3 cm)
	Weight: 0.5 lb (0.2 kg)

As of the date of manufacture, the unit has been tested and found to comply with specifications for CE marking.



INDICATORS:**NOTE**

Indicators are provided to denote an error with the net cable supplying network power to the CNTBLOCK. The LEDs do not signify wiring problems that exist on the network runs from the CNTBLOCK to other net devices.

There are three LED indicators located on the CNTBLOCK top panel, refer to figure 1. The combination of two LEDs, NORM ON (Y) and NORM OFF (Z), and their three states of illumination, bright, dim, and off, indicate whether wiring through the CNTBLOCK is correct. Refer to table 2 for LED illumination combinations and the associated wiring conditions.

Table 2. Wiring Conditions Per CNTBLOCK LED Illumination

POSSIBLE WIRING CONDITIONS	CNTBLOCK LED ILLUMINATION	
	NORM ON (Y)	NORM OFF (Z)
Correct	Bright	Dim
Both net wires disconnected	Off	Bright
Data Y net wire correct only	Bright	Bright
Data Z net wire correct only	Off	Dim
Data net wires swapped	Dim	Bright

POWER

The green LED illuminates when 24 volts is supplied to the CNTBLOCK over the network. If the +24V line is improperly connected, the POWER LED does not illuminate.

NORM ON (Y)

The red LED brightly illuminates in combination with an illuminated POWER LED and a dimly illuminated NORM OFF (Z) LED during normal operating conditions. Refer to table 2 for other states of illumination.

NORM OFF (Z)

The red LED illuminates dimly in combination with a brightly illuminated POWER and NORM ON (Y) LED during normal operating conditions. Refer to table 2 for other states of illumination.

INSTALLATION/SETUP:**Power Isolation**

If additional power supplies are needed for a CRESNET II system, care must be taken to isolate them from one another. The CNTBLOCK offers a convenient method for isolating network devices which should be powered by separate power supplies. Removing the jumper from the circuit board isolates the 24 V lines from one side of the CNTBLOCK to the other. The jumper is clearly marked (JUMPER) on the circuit board.

Preparation for Use

Refer to figure 2 for typical hook-up diagrams of the CNTBLOCK. Complete the following steps in the order provided to ensure proper installation of the unit.

NOTES

- 1. All CRESNET II network wiring should follow CRESTRON's network interconnection drawing. Although the CNTBLOCK can help diagnose some wiring problems, certain miswirings can cause damage to the CNTBLOCK or other network devices.*
 - 2. Network termination points are available at the control system power supply. Network units may also be daisy-chained together. For additional wiring information, refer to the latest revision of the CRESNET II reference manual section on CNPWS power supplies (Doc. 8091).*
 - 3. CRESTRON recommends that a diagnostic procedure using the CNTBLOCK be used before attaching new network devices.*
1. Before making any connections, review latest revision of network interconnection drawing (Doc. 5411).
 2. If using the CNTBLOCK with multiple power supplies, remove jumper as described in the Power Isolation section.
 3. Connect a network cable from one power supply to the CNTBLOCK.
 4. Connect additional CRESNET II devices to the CNTBLOCK, one at a time. Ensure proper connect of each device by observing CNTBLOCK LED illumination and referring to table 2.
 5. If connecting multiple power supplies and the jumper has been removed, use a network cable to connect the second power supply to the other side of the CNTBLOCK and repeat steps 3 and 4.

PROGRAMMING:

The CNTBLOCK does not require any specialized programming instructions.

FURTHER INQUIRIES:

If after reviewing this Operations Guide you still have additional questions, please contact a CRESTRON technical support representative by dialing (888) CRESTRON [(888) 273-7876].

METHOD 1: CONNECTION WITH MULTIPLE POWER SUPPLIES (JUMPER REMOVED)

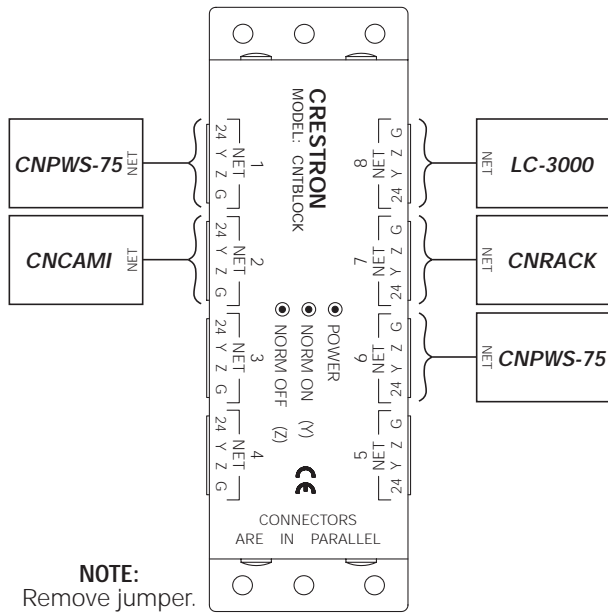

METHOD 2: CONNECTION WITH A SINGLE POWER SUPPLY

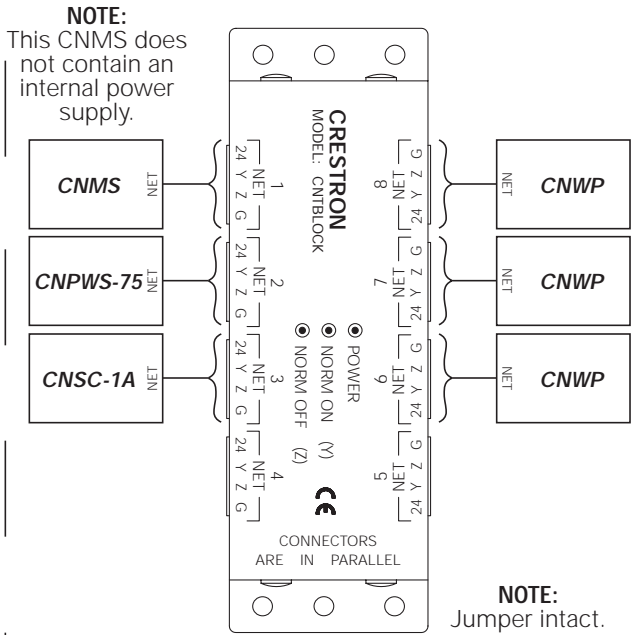

METHOD 3: CONNECTION WITH MULTIPLE POWER SUPPLIES (JUMPERS INTACT)

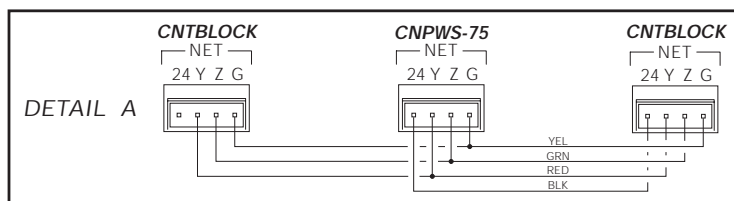
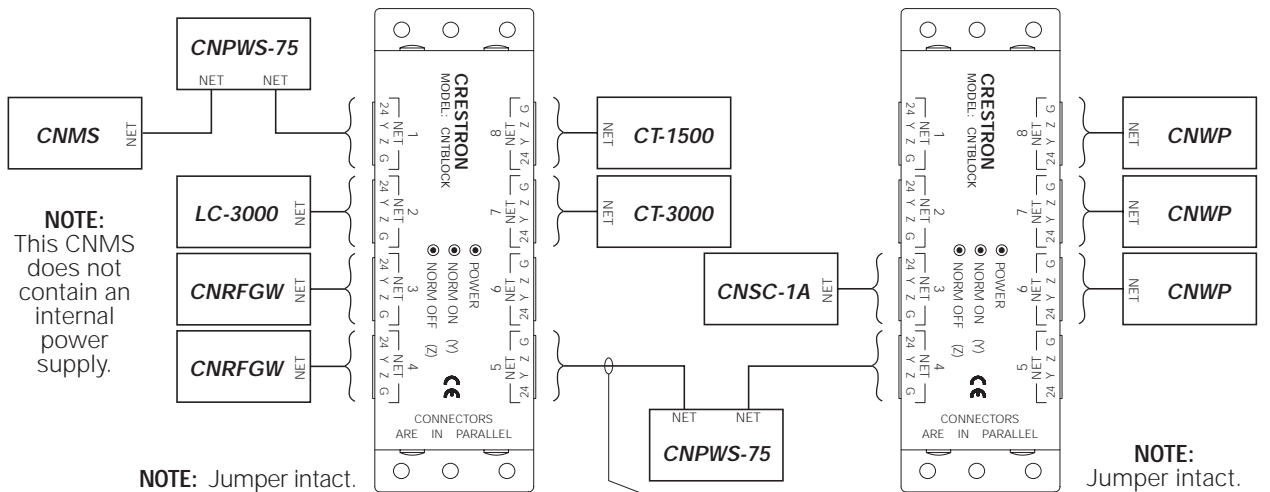

CAUTION:
Data wires (Y/Z) and ground (G) are connected. Do not connect the fourth wire (+24V). Refer to Detail A.

Figure 2. CNTBLOCK, Hook-up Diagrams