

Removing and Installing Route Processor Modules (RPMs)

Catalog Number: LC-ED-RPM

The E-Series requires the installation of at least one RPM although two are recommended for redundancy. RPMs are designed to be installed in either the R0 or R1 slot. Do not force them into line-card slots or permanent damage may result.



Warning:

- Always wear an ESD-preventive wrist or foot-heel ground strap when handling RPMs. After you remove the original packaging, place components on an antistatic surface.
- Do not remove a filler panel blank from the chassis unless you are ready to install an RPM into that slot. If you remove a card, immediately install a filler panel blank in the empty slot.

To remove and install an RPM:

Step	Task
1	If operating with a single RPM, power down the chassis prior to removing the RPM.
2	Unplug any cables connected to the RPM.
3	Loosen the captive screws and pull the ejector levers simultaneously toward you to disengage the backplane connections.
4	Slide the RPM out of the slot.
5	Hold the new RPM by the edges. Avoid touching the printed circuit board and connector pins. Extend the top and bottom card levers before you insert the card into the slot. (See figures below)
6	Align the card with the guide and gently slide it into the slot until you feel the connectors engage with the chassis backplane.
7	Rotate the levers to seat the backplane connectors and line card in place.
8	Secure the RPM in place by tightening the top and bottom screws.

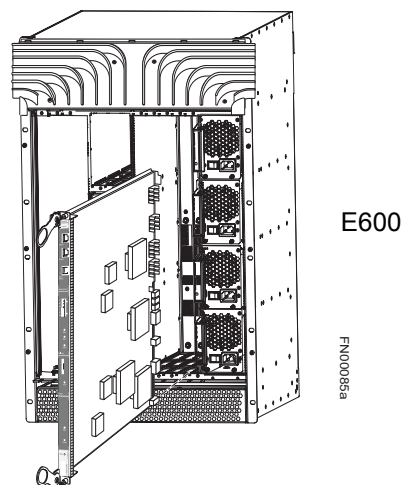
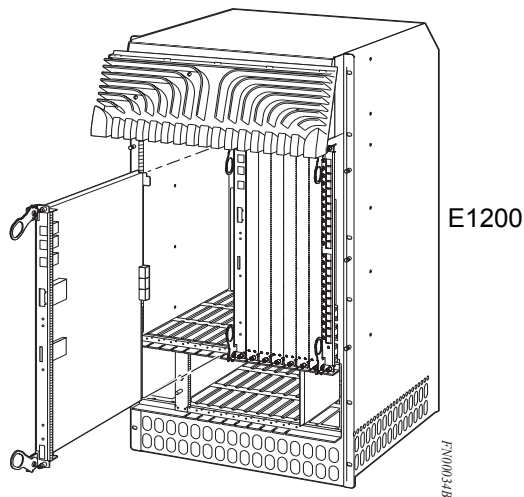

101-00052-00

Jumbo Frame Support

To operate an E-series in Jumbo mode, the chassis must contain only Jumbo-enabled cards:

- RPM (Catalog number LC-ED-RPM)
- 24-port GE line card with SFP optics (Catalog number LC-ED-1GE-24P)
- 2-port 10GE LAN PHY line card (Catalog number LC-ED-10GEL-2Y)

The chassis mode is determined during system boot. If the chassis boots up and contains a non-Jumbo-enabled card, FTOS operates in non-Jumbo mode. If the chassis boots up and contains only Jumbo-enabled cards, it will enable Jumbo mode.



Note: When operating in Jumbo mode (all cards are Jumbo-enabled), the Standby RPM must also be Jumbo-enabled (Catalog number LC-ED-RPM). Otherwise, the RPMs will not fail over correctly.

The table below describes the different card scenarios and the resulting chassis mode.

Table 1 E-Series Chassis Mode (Jumbo or non-Jumbo) with Different Cards

Chassis Contains	Chassis Mode
Only Jumbo-enabled cards	Jumbo
Mix of Non-Jumbo and Jumbo-enabled cards	Non-Jumbo
Only Jumbo-enabled cards, and a Non-Jumbo card is inserted	Remain in Jumbo mode, with the non-Jumbo-enabled card disabled. (show linecard all command will display card-problem for the non-Jumbo-enabled card.)
Only Non-Jumbo-enabled cards, and a Jumbo-enabled card is inserted	Remain in non-Jumbo mode, with the Jumbo-enabled card enabled. (the Jumbo-enabled card will only transmit and receive packets with link MTUs of 1554 and IP MTUs of 1500)

To determine what mode the chassis is in and if you have Jumbo-enabled cards, enter the **show chassis brief** command. The Chassis Mode field states if the mode is Jumbo or Non-Jumbo.

Table 2 RPM LEDs

Section	Label	Description
Management	Console Port	Use this RJ-45 jack for the initial system boot, as well as system configuration and monitoring.
	Auxiliary Port	Use this RJ-45 serial auxiliary port for modem connection
	10/100 Ethernet	Use this non-routable Ethernet port to download images and manage the system, for example, FTP and telnet operations. This port is provisioned with an RJ-45 jack. Port LEDs: L: Green: link is up. A: Green: activity on port
Alarms		Use the relay contacts to connect a remote alarm indicator to monitor alarm status. The top three contacts (next to the red bar) are for Major alarms and the bottom three contacts (next to the yellow bar) are for minor alarms. NC - Normally Closed C - Common NO - Normally Open
	Major LED	Red: a critical condition exists (such as a severe over temperature condition). Unlit: no major alarm conditions.
	Minor LED	Amber: a serious condition exists (such as a single fan failure or a line card failure). Unlit: no minor alarm conditions.
	ACO/LT Button	Audible alarm Cut Off/Lamp Test (ACO/LT) button allows you to test the operability of LEDs to verify that they are able to light. Pressing this button temporarily illuminates the LEDs on the RPM. If you press the ACO/LT button when an alarm LED is lit, the alarm relay contacts are reset until the next alarm event.
Flash	Slot	Use the multimedia card (external flash memory card) slot to store and retrieve boot and system images.
	In Use LED	Green: flash memory card is in the process of a read or write process. Do not remove the flash card when the In Use LED is lit. Unlit: not in use.
	Reset Button	Use this recessed reset switch to reset the RPM by inserting a small object, such as a pen tip, and depress the button.
	Primary LED	Indicates that this RPM is the Primary RPM. Green: primary Unlit: standby
	Status LED	Green: operational Amber: fault detected Flashing green: booting Unlit: in standby mode or power is off

