

LED	State	Description
Power	Green	The FortiGate unit is on.
	Off	The FortiGate unit is off.
WLAN	Green	Traffic on WLAN link.
Link (Internal, DMZ, WAN1, WAN2)	Green	The correct cable is in use and the connected equipment has power.
	Flashing Green	Network activity at this interface.
	Off	No link established.
100 (Internal, DMZ, WAN1, WAN2)	Green	The interface is connected at 100 Mbps.

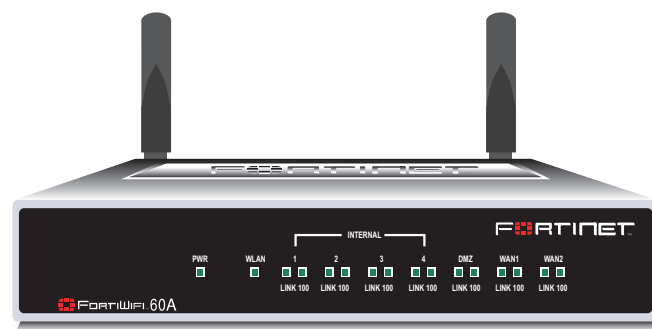

FortiWiFi-60A / AM



© Copyright 2007 Fortinet Incorporated. All rights reserved.
 Products mentioned in this document are trademarks or registered trademarks of their respective holders.
 Regulatory Compliance
 FCC Class A Part 15 CSA/CUS
 17 May 2007

01-30004-0287-20070517

1 Checking the Package Contents

Connector	Type	Speed	Protocol	Description
Internal	RJ-45	10/100 Base-T	Ethernet	4-port switch connection to up to four devices or the internal network.
WLAN	Antenna		802.11 a/b/g	Wireless connections to LAN.
WAN1 and 2	RJ-45	10/100 Base-T	Ethernet	Redundant connections to the Internet.
DMZ	RJ-45	10/100 Base-T	Ethernet	Optional connection to a DMZ network or to other FortiWiFi-60A/AM units for high availability (HA).
CONSOLE	RJ-45	9600 bps	RS-232 serial	Optional connection to the management computer. Provides access to the command line interface (CLI).
USB	USB		USB	Optional connection for FortiUSB key for firmware backup and installation.
Phone cable	RJ-11			Phone line for internal modem.

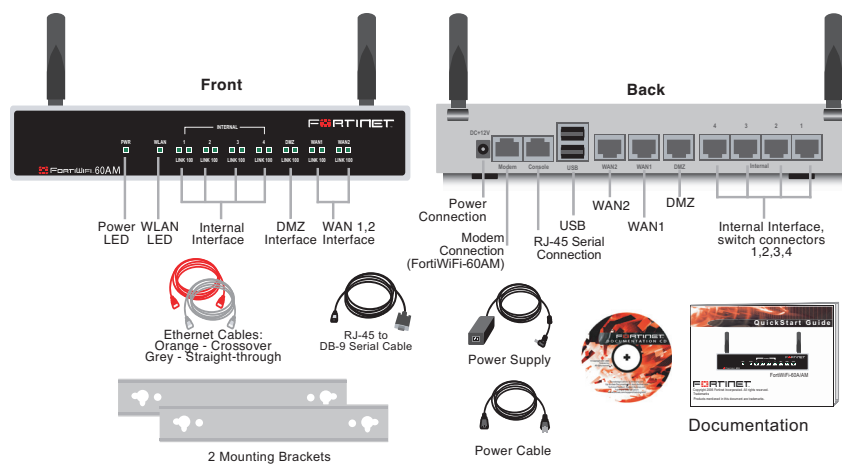

2 Connecting

Connect the FortiWiFi unit to a power outlet and to the internal and external networks.

- Place the unit on a stable surface. It requires 1.5 inches (3.75 cm) clearance above and on each side to allow for cooling.
- Locate the FortiWiFi-60 in a prominent location within a room for maximum coverage, rather than in a corner.
- Be aware of the construction of your environment, concrete and metal walls can hamper signal strength.
- Keep the AP and wireless devices at least 10 feet away from appliances such as microwave ovens and cordless phones.

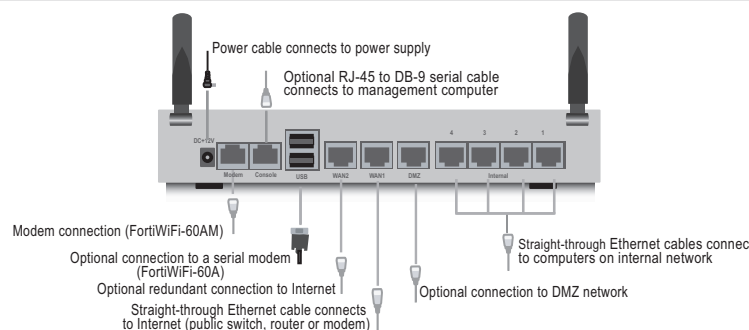

3 Planning the Configuration

Before beginning to configure the FortiWiFi unit, you need to plan how to integrate the unit into your network. Your configuration plan is dependent upon the operating mode that you select: NAT/Route mode (the default) or Transparent mode.

Quick configuration using the default settings

You can quickly set up your FortiWiFi unit for a home or small office using the web-based manager and the default settings in NAT/Route mode. All you need to do is set your network computers to use DHCP, access the web-based manager, and configure the required settings for the WAN1 interface. You can also configure DNS and a default route if needed. The FortiWiFi unit automatically assigns IP addresses to up to 100 computers in the internal network.

- Connect the FortiWiFi unit to the network.
- Set all the network computers to use DHCP to automatically obtain an IP address. The FortiGate internal interface acts as a DHCP server for the internal network and assigns IP addresses to all computers in the range 192.168.1.110 – 192.168.1.210.
- From the management computer browse to <https://192.168.1.99>. The FortiGate web-based manager appears.
- Go to **System > Network > Interface** and select Edit for the WAN1 interface.

- Select one of the following Addressing modes
 - Manual: enter a static IP address and netmask, select OK, and go to step 6
 - DHCP: to get an IP address from the ISP select DHCP and go to step 9
 - PPPoE: to get an IP address from the ISP select PPPoE and go to step 9
- Go to **System > Network > DNS**.
- Select one of the following DNS settings
 - Obtain DNS server address automatically: select to get the DNS addresses from the ISP, select Apply
 - Use the following DNS server addresses: select and enter the DNS server addresses given to you by the ISP, select Apply
- Go to **Router > Static**, select Create New, enter the default gateway address and select OK. Network configuration is complete. Proceed to part 7 of this *Quick Start Guide*.
- Select Retrieve default gateway from server and Override internal DNS options if your ISP supports them, select OK, and proceed to part 7 of this *Quick Start Guide*. Go to step 6 if you are not selecting these options.

NAT/Route mode

In NAT/Route mode, each FortiWiFi unit is visible to the network that it is connected to. All of its interfaces are on different subnets. Each interface that is connected to a network must be configured with an IP address that is valid for that network. You would typically use NAT/Route mode when the FortiWiFi unit is deployed as a gateway between private and public networks. In its default NAT/Route mode configuration, the unit functions as a firewall. Firewall policies control communications through the FortiWiFi unit. No traffic can pass through the FortiWiFi unit until you add firewall policies.

In NAT/Route mode, firewall policies can operate in NAT mode or in Route mode. In NAT mode, the FortiWiFi unit performs network address translation before IP packets are sent to the destination network. In Route mode, no translation takes place.

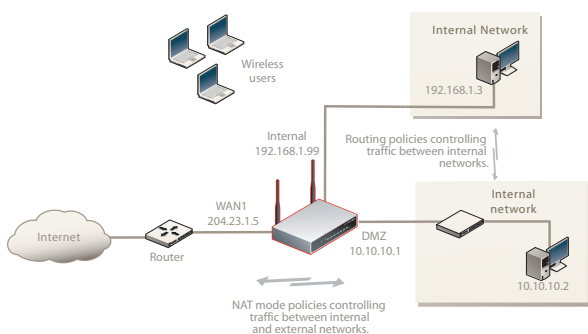

Transparent mode

In Transparent mode, the FortiWiFi unit is invisible to the network. All of its interfaces are on the same subnet. You only have to configure a management IP address so that you can make configuration changes.

You would typically use the FortiWiFi unit in Transparent mode on a private network behind an existing firewall or behind a router. In its default Transparent mode configuration, the unit functions as a firewall. No traffic can pass through the FortiWiFi unit until you add firewall policies. You can connect up to four network segments to the FortiWiFi unit to control traffic between these network segments.

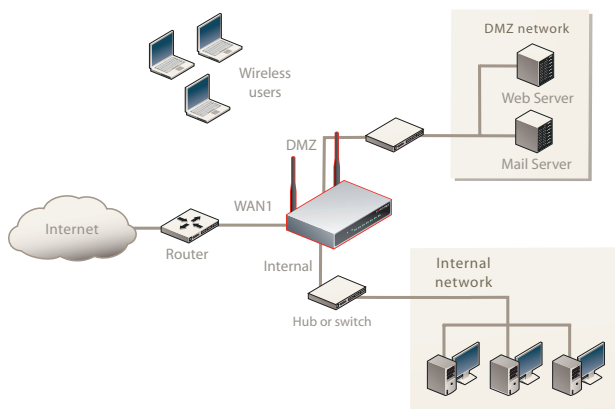

4 Choosing a Configuration Tool

Web-based manager

The FortiWiFi web-based manager is an easy to use management tool. Use it to configure the administrator password, the interface and default gateway addresses, and the DNS server addresses.

Requirements:

- An Ethernet connection between the FortiWiFi unit and management computer.
- Internet Explorer 6.0 or higher on the management computer.

Command Line Interface (CLI)

The CLI is a full-featured management tool. Use it to configure the administrator password, the interface addresses, the default gateway address, and the DNS server addresses. To configure advanced settings, see the Documentation CD-ROM.

Requirements:

- The RJ-45 to DB9 connection between the FortiWiFi unit and management computer.
- A terminal emulation application (HyperTerminal for Windows) on the management computer.

5 Collecting Information

NAT/Route Mode

Internal Interface:	IP:	_____
	Netmask:	_____
WLAN Interface:	IP:	_____
	Netmask:	_____
WAN1 Interface:	IP:	_____
	Netmask:	_____
WAN2 Interface	IP:	_____
	Netmask:	_____
DMZ	IP:	_____
	Netmask:	_____

The internal interface IP address and netmask must be valid for the internal network.

Transparent mode

Management IP:	IP:	_____
	Netmask:	_____

The management IP address and netmask must be valid for the network from which you will manage the FortiWiFi unit.

General settings

Administrator password:	_____	
Network Settings:	Default Gateway:	_____
	Primary DNS Server:	_____
	Secondary DNS Server:	_____

A default gateway is required for the FortiWiFi unit to route connections to the Internet.

Factory default settings

NAT/Route mode		Transparent mode	
Internal interface	192.168.1.99	Management IP	0.0.0.0
WAN1 interface	192.168.100.99	Wireless settings	
WAN2 interface	192.168.101.99	Mode	Access Point
WLAN interface	10.10.80.1	SSID	fortinet
DMZ interface	10.10.10.1	Geography	World
DHCP server on Internal interface	192.168.1.110 – 192.168.1.210	Channel	5
		Administrative account settings	
		User name	admin
		Password	(none)

6 Configuring the FortiWiFi Unit

Web-based Manager

1. Connect the FortiWiFi internal interface to a management computer Ethernet interface. Use a cross-over Ethernet cable to connect the devices directly. Use straight-through Ethernet cables to connect the devices through a hub or switch.
2. Configure the management computer to be on the same subnet as the internal interface of the FortiWiFi unit. To do this, change the IP address of the management computer to 192.168.1.2 and the netmask to 255.255.255.0.
3. To access the FortiWiFi web-based manager, start Internet Explorer and browse to <https://192.168.1.99> (remember to include the "s" in https://).
4. Type admin in the Name field and select Login.

NAT/Route mode

To change the administrator password

1. Go to **System > Admin > Administrators**.
2. Select Change Password for the admin administrator and enter a new password.

To configure interfaces

1. Go to **System > Network > Interface**.
2. Select the edit icon for each interface to configure.
3. Set the addressing mode for the interface. (See the online help for information.)
 - For manual addressing, enter the IP address and netmask for the interface.
 - For DHCP addressing, select DHCP and any required settings.
 - For PPPoE addressing, select PPPoE, and enter the username and password and any other required settings.

To configure the Primary and Secondary DNS server IP addresses

1. Go to **System > Network > Options**, enter the Primary and Secondary DNS IP addresses that you recorded above and select Apply.

To configure a Default Gateway

1. Go to **Router > Static** and select Edit icon for the static route.
2. Set Gateway to the Default Gateway IP address you recorded above and select OK.

Transparent mode

To switch from NAT/route mode to transparent mode

1. Go to **System > Status**, select Transparent.
2. Set the Management IP/Netmask to 192.168.1.99/24.
3. Set the Default Gateway and select Apply.

To change the administrator password

1. Go to **System > Admin > Administrators**.
2. Select Change Password for the admin administrator and enter a new password.

To change the management interface

1. Go to **System > Config > Operation Mode**.
2. Enter the Management IP address and netmask that you recorded above and select Apply.

To configure the Primary and Secondary DNS server IP addresses

1. Go to **System > Network > Options**, enter the Primary and Secondary DNS IP addresses that you recorded above and select Apply.

Command Line Interface

1. Use the RJ-45 to DB9 cable to connect the FortiWiFi Console port to the management computer serial port.
2. Start a terminal emulation program (HyperTerminal) on the management computer. Use these settings:
3. Baud Rate (bps) 9600, Data bits 8, Parity None, Stop bits 1, and Flow Control None.
4. At the Login: prompt, type admin and press Enter twice (no password required).

NAT/Route mode

1. Configure the FortiWiFi internal interface.

```
config system interface
  edit internal
    set ip <intf_ip>/<netmask_ip>
  end
```
2. Repeat to configure each interface, for example, to configure the WAN1 interface.

```
config system interface
  edit wan1
    ...
  end
```
3. Configure the primary and secondary DNS server IP addresses.

```
config system dns
  set primary <dns-server_ip>
  set secondary <dns-server_ip>
end
```
4. Configure the default gateway.

```
config router static
  edit 1
    set gateway <gateway_ip>
  end
```

Transparent Mode

1. Change from NAT/Route mode to Transparent mode and configure the Management IP address.

```
config system settings
  set opmode transparent
  set manageip <mng_ip>/<netmask>
end
```
2. Configure the DNS server IP address.

```
config system dns
  set primary <dns-server_ip>
  set secondary <dns-server_ip>
end
```

7 Completing the Configuration

Congratulations!

You have finished configuring the basic settings. Your network is now protected from Internet-based threats. To explore the full range of configuration options, see the online help or the Documentation CD-ROM.

Visit these links for more information and documentation for your Fortinet product.

- Technical Documentation - <http://docs.forticare.com>
- Fortinet Knowledge Center - <http://kc.forticare.com>
- Fortinet Technical Support - <http://support.fortinet.com>