

Front View

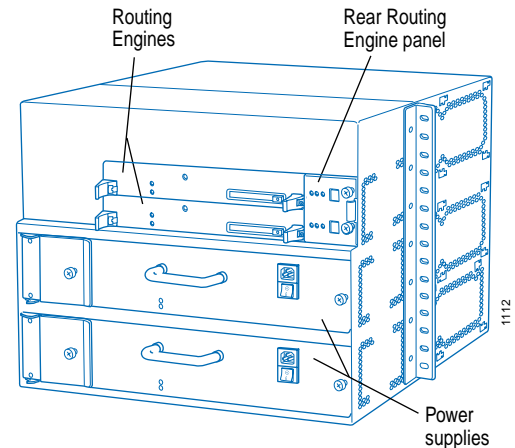

Rear View

M20 Router Major Hardware Components

Component	Quantity	Function	Redundant	Field-replaceable	Offline Button
Flexible PIC Concentrators (FPCs)	1-4	Connects PICs to router components, houses shared memory	-	Hot-removable Hot-insertable	Yes
Physical Interface Cards (PICs)	1-4 per FPC	Provides interfaces to various network media	-	From removed FPC	Yes
System and Switch Boards (SSBs)	1-2	Performs route lookups, manages shared memory, transfers control packets	-	Hot-pluggable	-
Routing Engine	1-2	Handles routing protocols, maintains routing tables	-	Hot-pluggable	Yes
Power supplies	2 AC or 2 DC	Distributes voltages to components	Yes	Hot-removable Hot-insertable	-
Cooling system	3 fan trays and 1 rear Routing Engine fan	Cools router components	Yes	Hot-removable Hot-insertable	-
Craft interface	1	Displays status and allows you to perform control functions	-	Hot-removable Hot-insertable	-

Hot-removable and hot-insertable—Can remove and replace without powering down the router or disrupting routing functions.

Hot-pluggable—Can remove without powering down the router, but forwarding is interrupted, or router switches to warm shutdown mode, until replacement is installed.

M20 Router Physical Specifications

Dimensions	14 in. (36 cm) high x 19 in. (48.3) wide x 21 in. (54 cm) deep
Weight	80 lb (36 kg) minimum configuration 134 lb (61 kg) maximum configuration
Required clearances	19 in. (48 cm) front and rear; 6 in. (15.2 cm) each side

M20 Internet Backbone Router

M20 Router Power Supply Specifications

Specification	AC	DC
Maximum power consumption	750 W	750 W
Input voltage	90 through 264 VAC operating range	-40 through -72 VDC operating range
Input line frequency	47-63 Hz, autoranging	-
Input current rating	13 A @ 90 V	24 A @ -48 V (typical)
Output voltages	+3.3 V; +5 V; +2.5 V; +12 V; +24 V	+3.3 V; +5 V; +2.5 V; +12 V; +24 V
Power and grounding cords and cables	Country-specific; see <i>M20 Internet Backbone Router Hardware Installation Guide</i>	4 or 6 AWG wire cables with dual hole ¼-20 UNC terminal studs @ 15.86 mm (0.625 in.) centers

M20 Router LEDs

Component	LED	Location
FPCs	Green OK Amber FAIL	Craft interface
PICs	1 LED per port, with 4 states: Red, Green, Amber, Off	PIC faceplate
SSBs	Blue MASTER Green ONLINE Amber OFFLINE 2 Green STATUS	SSB faceplate
Routing Engine	Blue MASTER Green ONLINE Amber OFFLINE	Craft interface and Routing Engine panel
Power supplies	Green OK Red FAIL	Power supply faceplate
Alarm LEDs		
Red alarm	Large circular red	Craft interface
Yellow alarm	Large triangular amber	Craft interface

Taking Components Offline

Component	Procedure
FPC	<ol style="list-style-type: none"> 1. Press the FPC offline button, located on the right side of the craft interface, for the appropriate FPC. 2. Press and hold the button until the amber FAIL LED lights (about 5 seconds).
PIC	Remove the FPC containing the PIC (this will take all interfaces on the removed FPC offline).
SSB	<ol style="list-style-type: none"> 1. Press the SSB offline button on the SSB faceplate. 2. Press and hold the button until the amber SSB OFFLINE LED lights (about 5 seconds).
Routing Engine	<ol style="list-style-type: none"> 1. Press the Routing Engine (RE0 or RE1) offline button on the craft interface or on the Routing Engine panel. 2. Press and hold the button until the amber OFFLINE LED lights. <p>You can take the backup Routing Engine offline without interrupting the functioning of the router. If you take the master Routing Engine offline, the router reboots with the other Routing Engine functioning as master. The routing and forwarding functions are interrupted during this process.</p>

System Architecture

The router has two major architectural components: the Routing Engine, which provides Layer 3 routing services and network management; and the Packet Forwarding Engine, which provides packet switching, route lookups, and packet forwarding. The Routing Engine and Packet Forwarding Engine operate independently, but constantly communicate through a 100-Mbps link, as illustrated in the figure at the right.

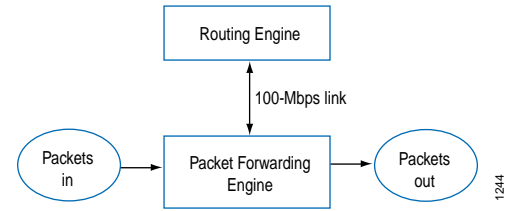

1244

Packet Flow through the Packet Forwarding Engine

To ensure efficient packet flow through the system, data packet forwarding is handled by ASICs on the hardware components. The figure at the right shows the sequence of packet flow through the Packet Forwarding Engine.

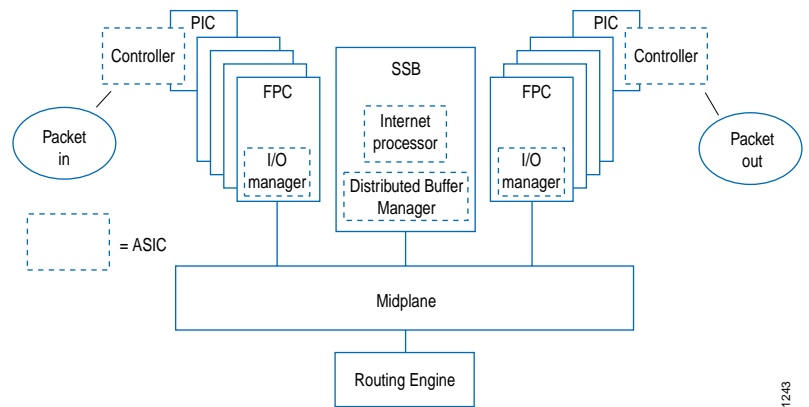

1243

Routing Engine Architecture

The Routing Engine handles all the routing protocol processes as well as processes controlling interfaces, router components, system management, and user access. These processes run on top of a kernel that interacts with the Packet Forwarding Engine.

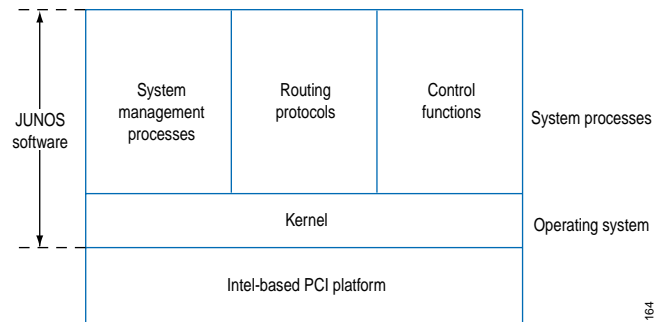

1164

Control Packet Handling

The Routing Engine constructs and maintains routing tables, and derives a table of active routes, called the forwarding table, from the routing tables. The forwarding table is then copied into the Packet Forwarding Engine.

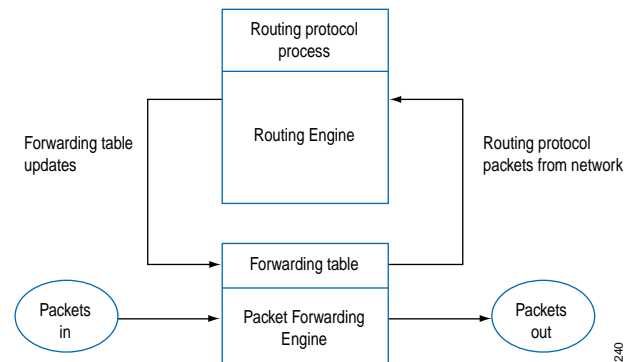

1240

M20 Internet Backbone Router

General Safety Guidelines

- Only trained and qualified personnel should install or replace the router.
- Perform only the procedures described in the *M20 Internet Backbone Router Hardware Installation Guide*. Other services should be performed by authorized service personnel only.
- For protection against shock hazard, verify that all power cables are disconnected before servicing the router.
- Before installing the router, read the guidelines in the “Prepare the Site” section of the *M20 Internet Backbone Router Hardware Installation Guide* to make sure that the site meets power, environmental, and clearance requirements for the router.
- Manually installing the router requires two people to lift the chassis and a third person to secure the mounting screws. Before lifting the chassis, and remove components as described in the *M20 Internet Backbone Router Hardware Installation Guide*. To prevent injury, keep your back straight and lift with your legs, not your back. Do not attempt to lift the chassis with the handles on the power supplies.
- Do not work on the router or connect or disconnect cables during electrical storms.
- Never install electrical jacks in wet locations unless the jacks are specifically designed for wet environments.
- Operate the router only when the grounding wire is connected.
- Use copper conductors only.
- Avoid touching uninsulated electrical wires or terminals that have not been disconnected from their power source. Doing so could cause electrical shock.
- Do not open or remove chassis covers or sheet metal parts when instructions are not provided in the *M20 Internet Backbone Router Hardware Installation Guide*. Doing so could cause severe electrical shock.
- Do not push or force any objects through any of the openings in the chassis frame. Doing so could result in electrical shock or fire.
- Avoid spilling liquid into the router chassis or onto any router components. Doing so could cause electrical shock or damage the router.
- Before working on equipment that is connected to power lines, remove jewelry, including rings, necklaces, and watches. Metal objects heat up when connected to power and ground and can cause serious burns or weld the metal object to the terminals.
- Failure to observe these safety warnings could result in serious physical injury.

Agency Approvals

Category	Approval
Safety	<ul style="list-style-type: none"> ■ CSA C22.2 No. 950 ■ UL 1950 ■ EN 60950, Safety of Information Technology Equipment ■ EN 60825-1 Safety of Laser Products—Part 1: Equipment Classification, Requirements and User’s Guide ■ EN 60825-2 Safety of Laser Products—Part 2: Safety of Optical Fibre Communication Systems
EMI	<ul style="list-style-type: none"> ■ AS 3548 Class A (Australia) ■ EN 55022 Class A emissions (Europe) ■ FCC Class A (USA) ■ VCCI Class A (Japan)
Immunity	<ul style="list-style-type: none"> ■ EN 61000-3-2 Power Line Harmonics ■ EN 61000-4-2 ESD ■ EN 61000-4-3 Radiated Immunity ■ EN 61000-4-4 EFT ■ EN 61000-4-5 Surge ■ EN 61000-4-6 Low Frequency Common Immunity ■ EN 61000-4-11 Voltage Dips and Sags
NEBS	<p>The router has been tested to meet the following standards:</p> <ul style="list-style-type: none"> ■ GR-63-Core: NEBS, Physical Protection ■ GR-1089-Core: EMC and Electrical Safety for Network Telecommunications Equipment ■ SR-3580 NEBS Criteria Levels (Level 3 Compliance)
ETSI	<ul style="list-style-type: none"> ■ ETS-300386-2 Switching Equipment

www.juniper.net

For support issues, contact the Juniper Networks Technical Assistance Center (JTAC) at 1-888-314-JTAC (within the United States) or 408-745-2121 (from outside the United States). For other contact information, refer to www.juniper.net/contactus.html.